

[54] COMBINED BACK REST AND LUGGAGE RACK

[76] Inventor: Willard S. Larson, Box 338, Isanti, Minn. 55040

[**] Term: 14 Years

[21] Appl. No.: 658,580

[22] Filed: Oct. 9, 1984

[52] U.S. Cl. D12/119; D12/158

[58] Field of Search D12/158, 119; 224/31, 224/30 R, 39; 297/DIG. 9

[56] References Cited

U.S. PATENT DOCUMENTS

D. 223,070 3/1972 Heltzen et al. D12/158

OTHER PUBLICATIONS

Cycle World, 4/77, p. 32, Combined Back Rest & Luggage Rack.

J. C. Whitney Motorcycle Parts & Accessories Catalog

No. 28 C, ©1983, p. 3, Square Tube Carrier with Back Rest, bottom of page.

J. C. Whitney Motorcycle Parts & Accessories Catalog No. 28 C, ©1983, p. 23, Deluxe Chrome-Plated Luggage Rack & Back Rest, lower center of page.

Primary Examiner—James M. Gandy

Attorney, Agent, or Firm—Burd, Bartz & Gutenkauf

[57] CLAIM

The ornamental design for a combined back rest and luggage rack, as shown.

DESCRIPTION

FIG. 1 is a perspective view of the combined back rest and luggage rack showing my new design;

FIG. 2 is an enlarged side elevation view of the right side of FIG. 1;

FIG. 3 is a top plan view thereof;

FIG. 4 is a front elevation view thereof;

FIG. 5 is a rear elevation view thereof; and

FIG. 6 is a bottom plan view thereof.

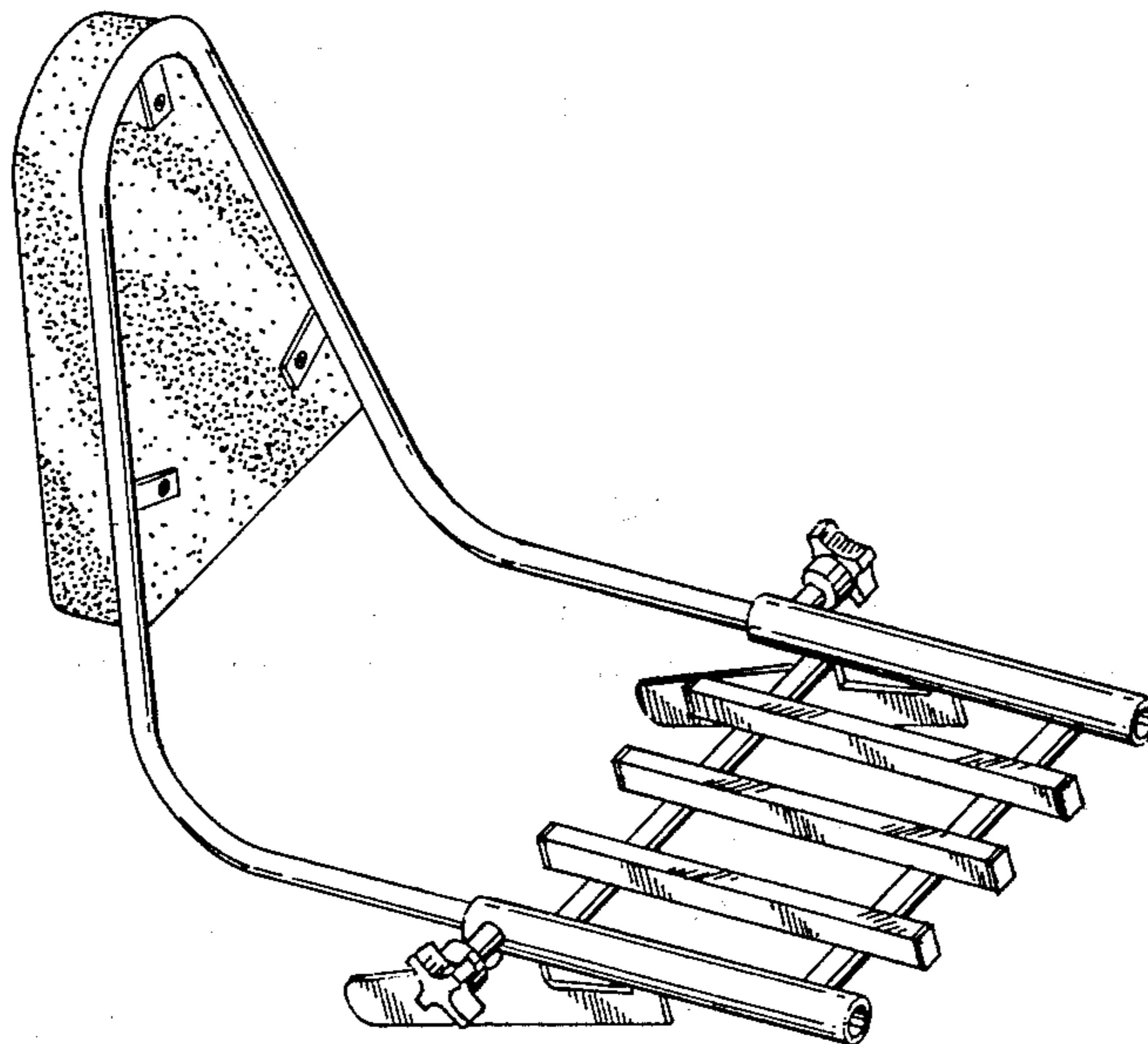

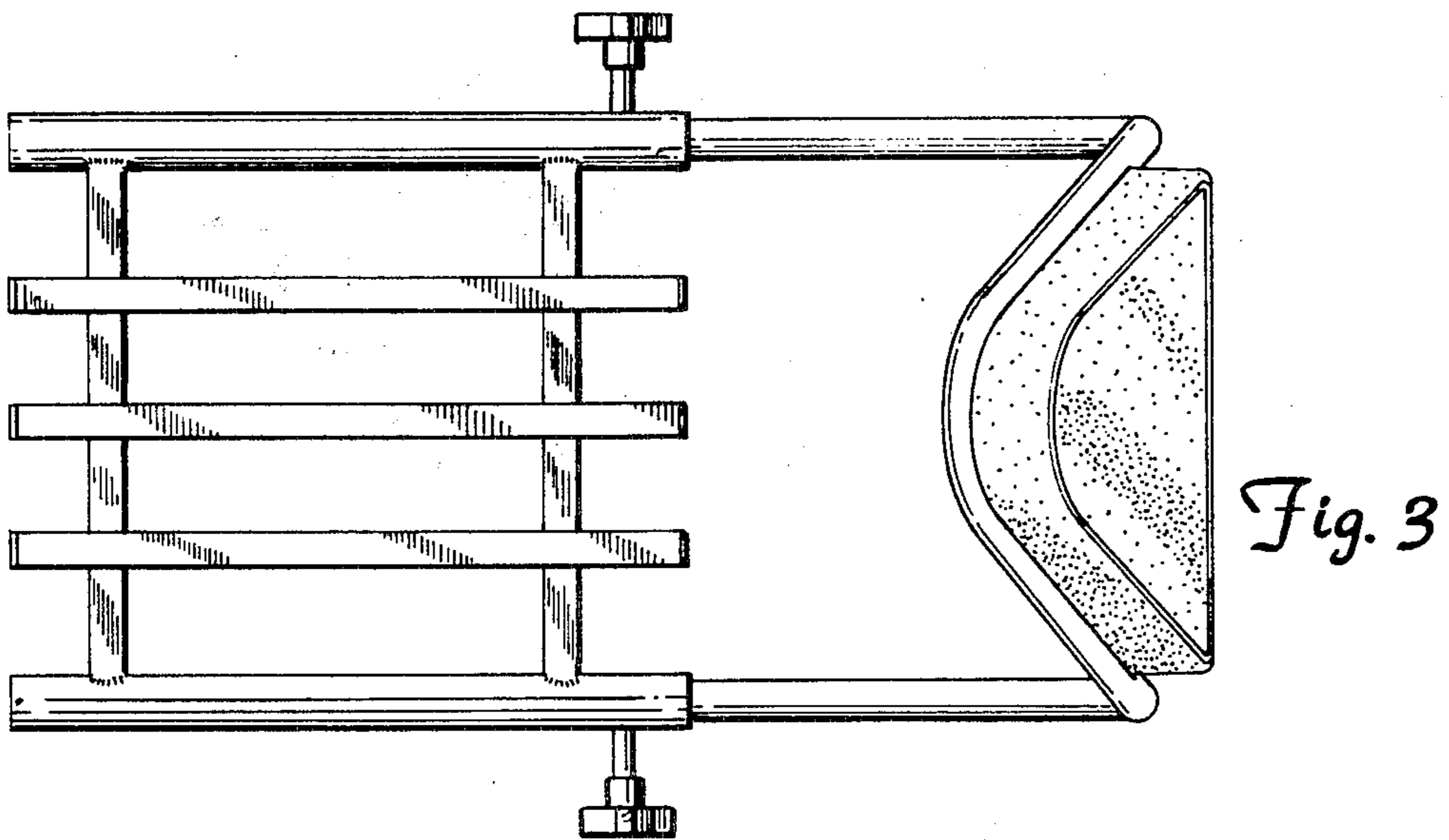
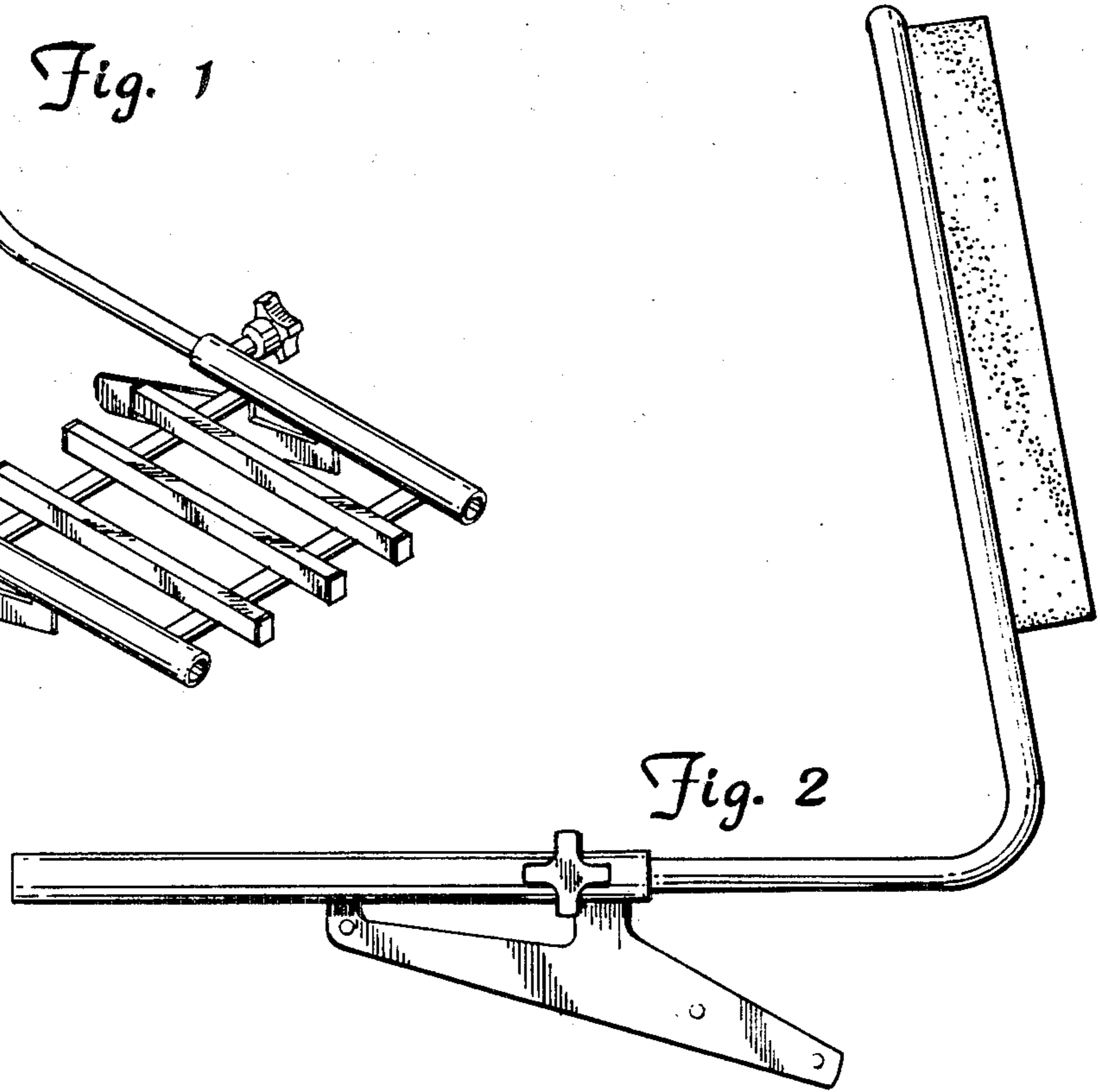
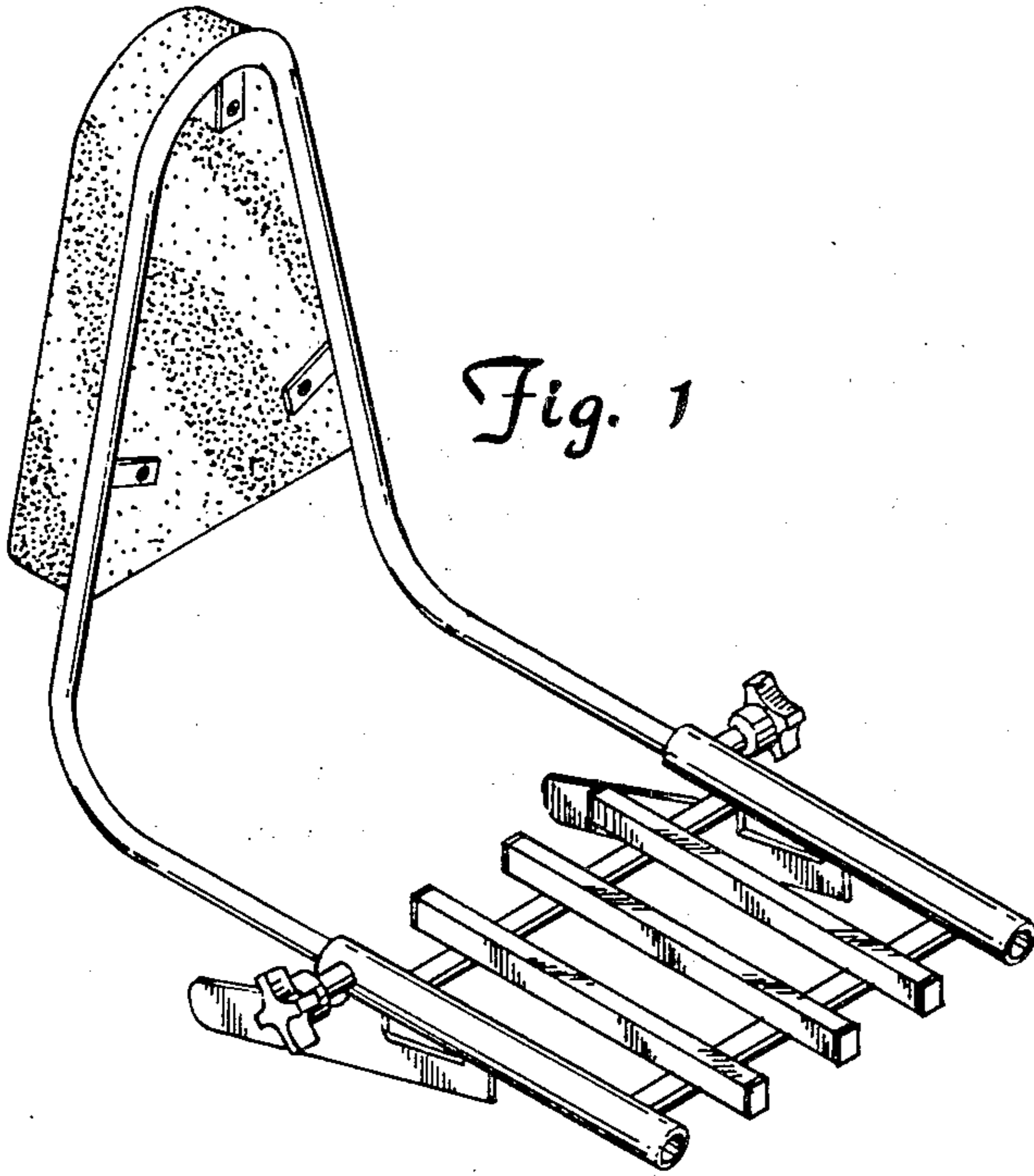

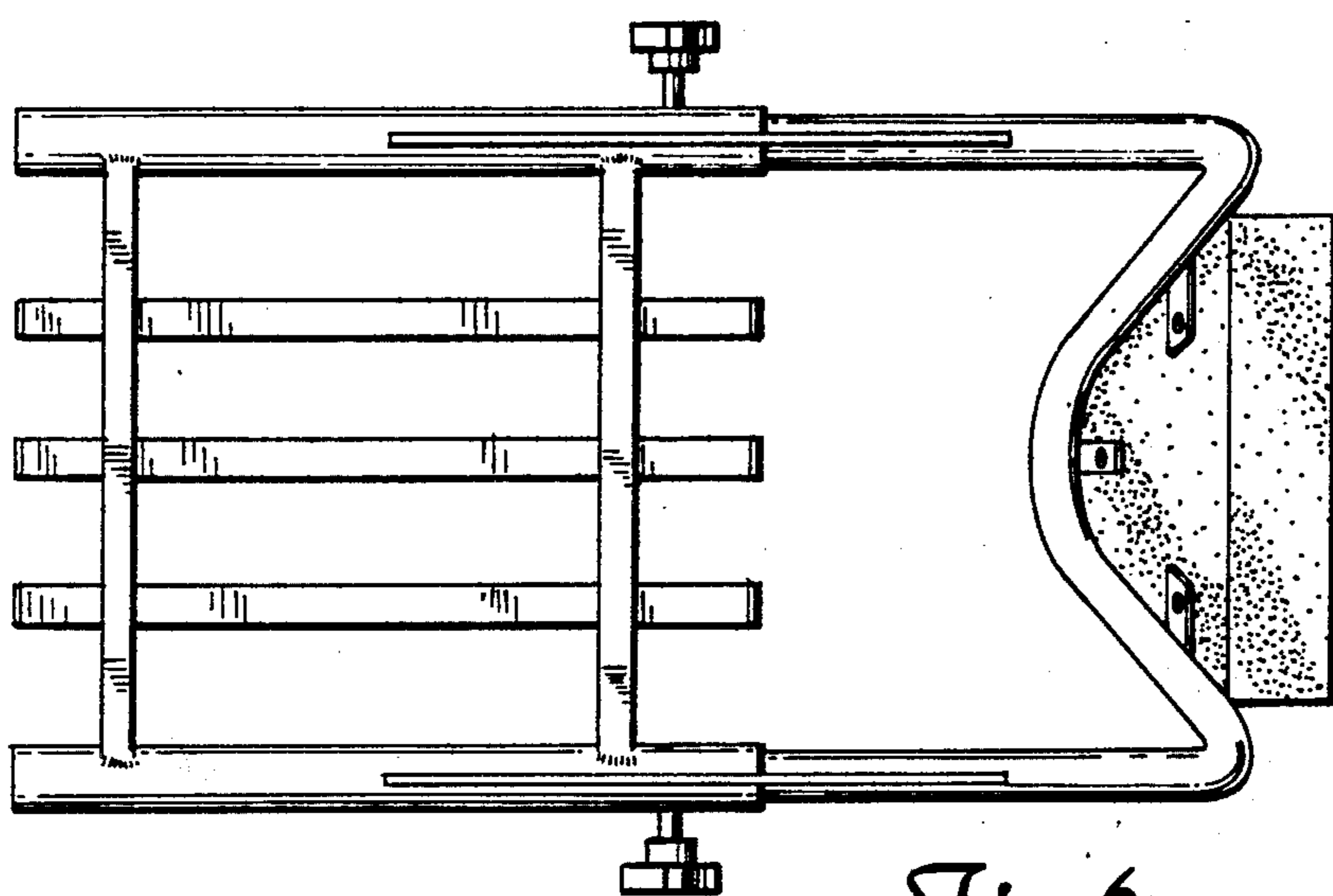
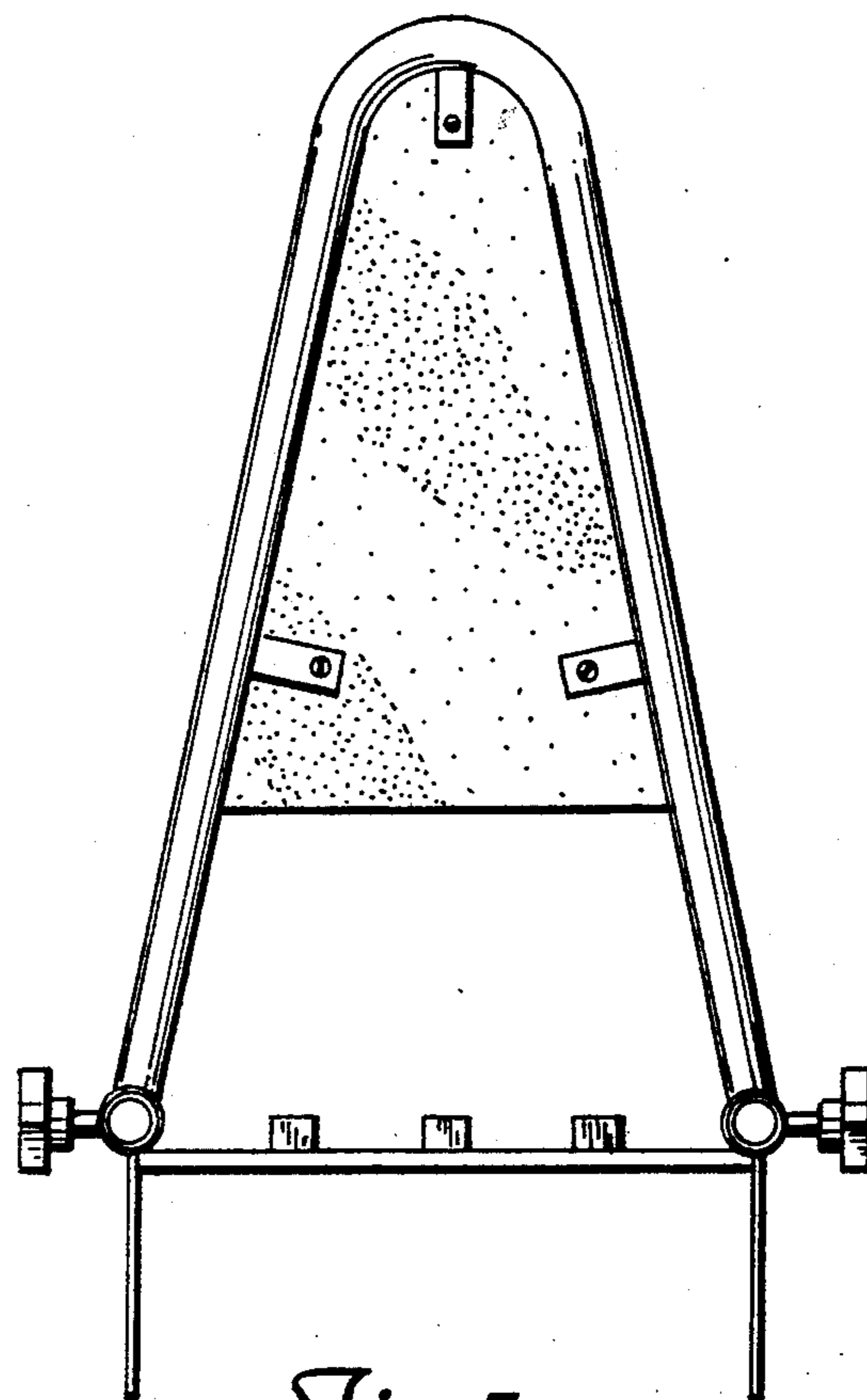
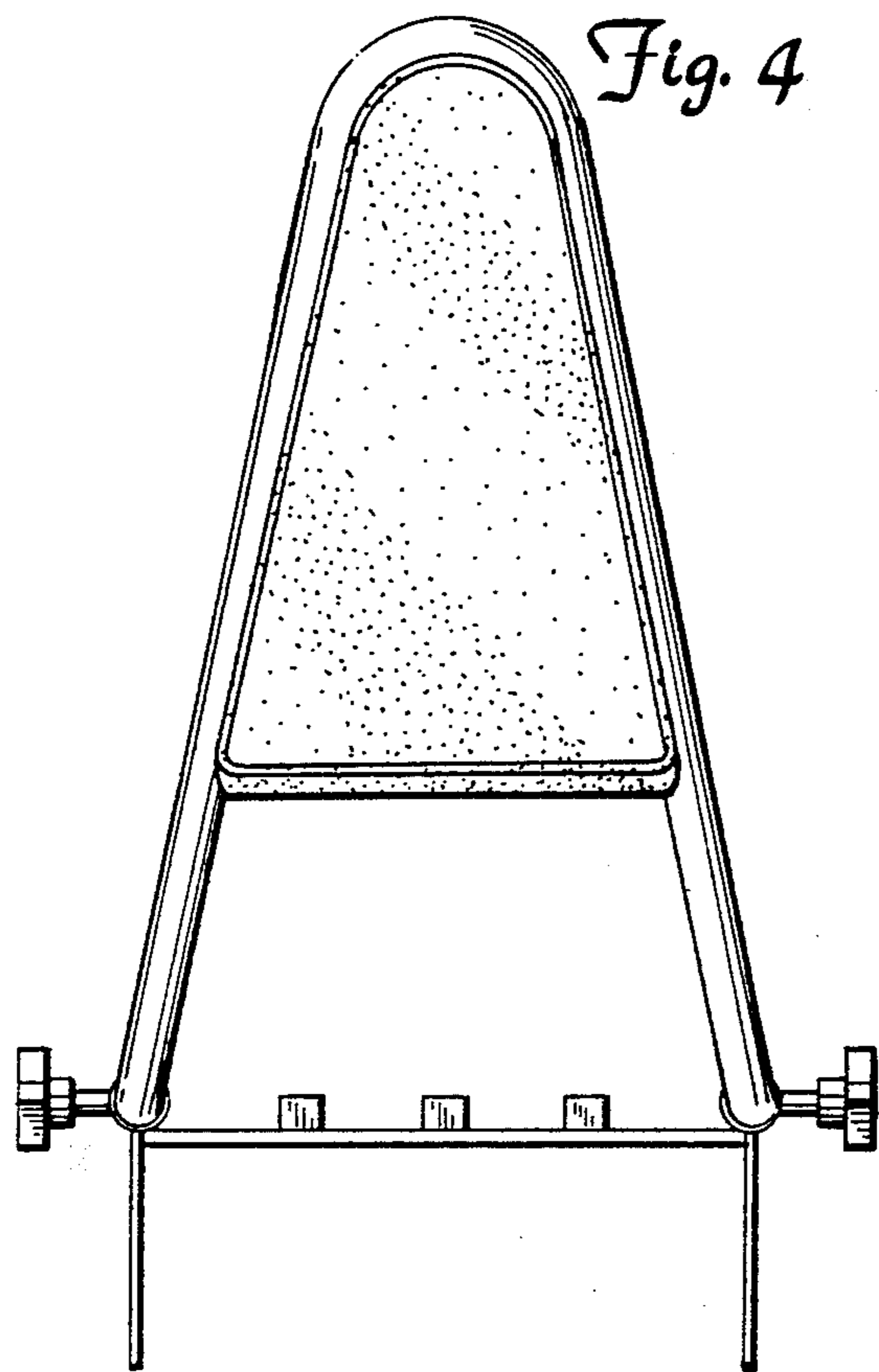

Fig. 6