

[54] BUS VEHICLE

[76] Inventor: Paul Legueu, 85 avenue de Mazy, 44380 Pornichet, France

[*] Notice: The portion of the term of this patent subsequent to Feb. 7, 1998 has been disclaimed.

[**] Term: 14 Years

[21] Appl. No.: 577,386

[22] Filed: Feb. 6, 1984

[52] U.S. Cl. D12/84

[58] Field of Search D12/84; 296/178

[56] References Cited

U.S. PATENT DOCUMENTS

D. 272,524 2/1984 Legueu D12/84

Primary Examiner—James M. Gandy
Attorney, Agent, or Firm—Fidelman, Wolfe and Waldron

[57] CLAIM

The ornamental design for a bus vehicle, as shown.

DESCRIPTION

FIG. 1 is a right front perspective view of a bus vehicle showing my new design;
FIG. 2 is a left rear perspective view thereof;
FIG. 3 is a front elevation view thereof;
FIG. 4 is a rear elevation view thereof; and
FIG. 5 is a top plan view thereof.

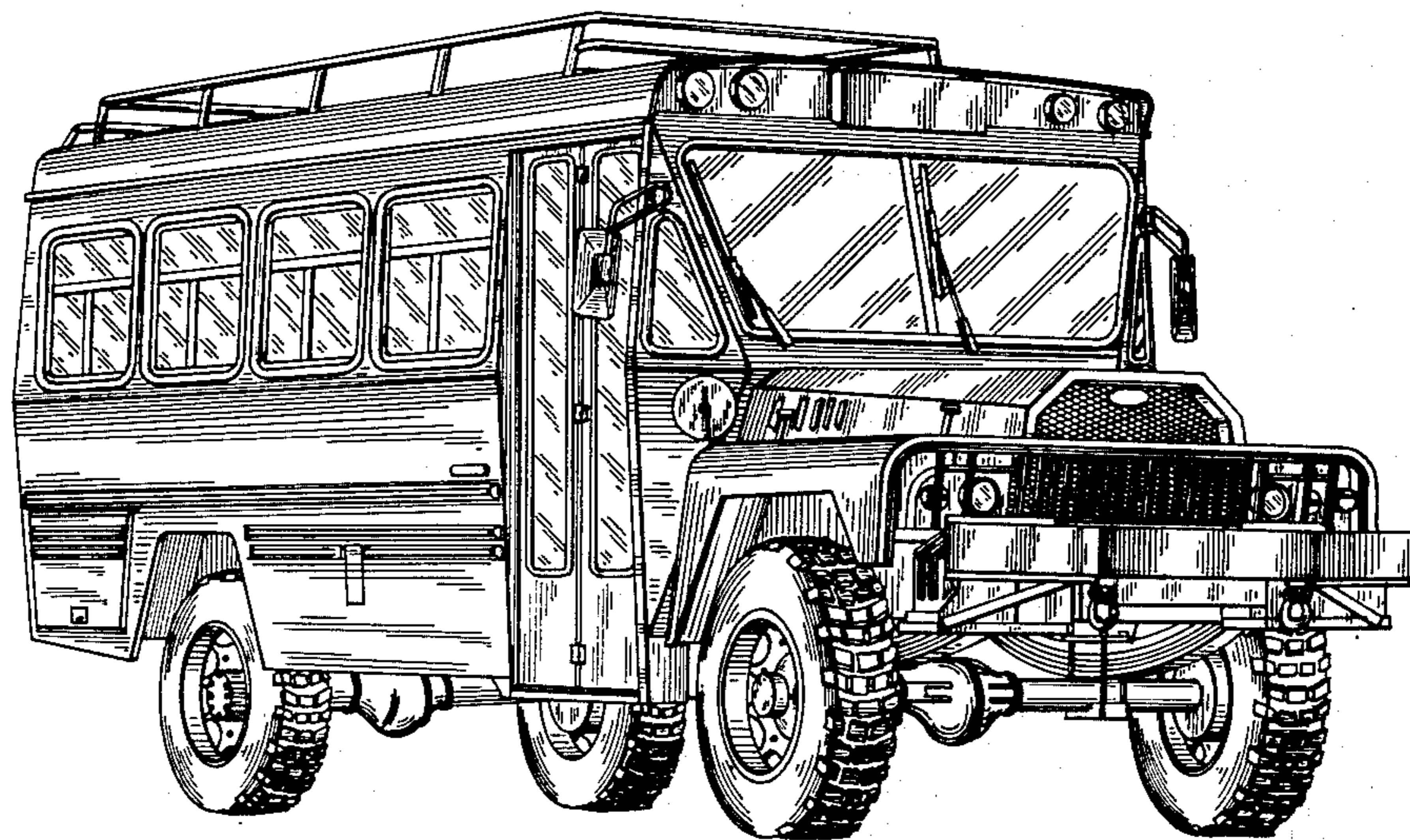

Fig. 1

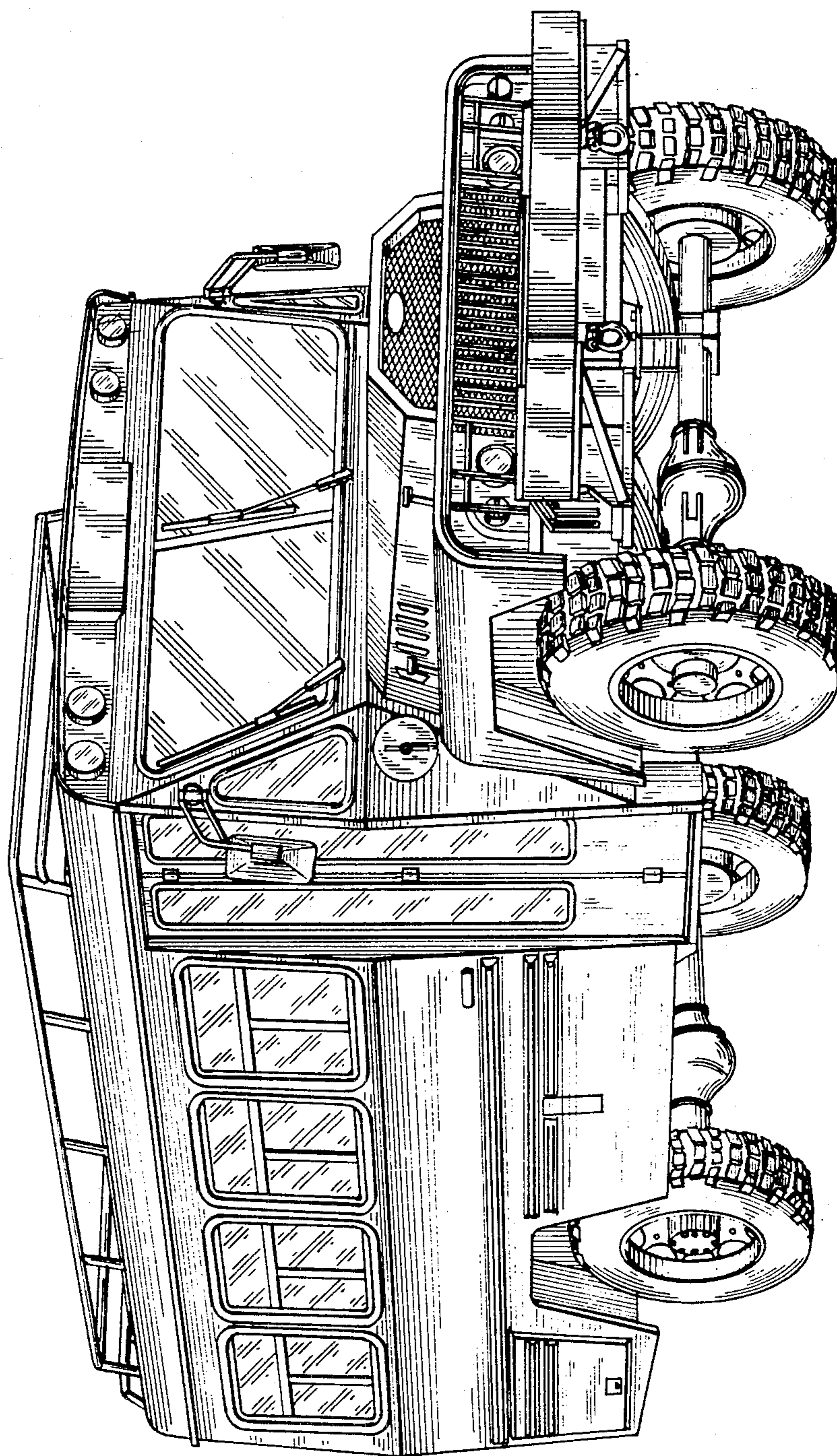

Fig. 2

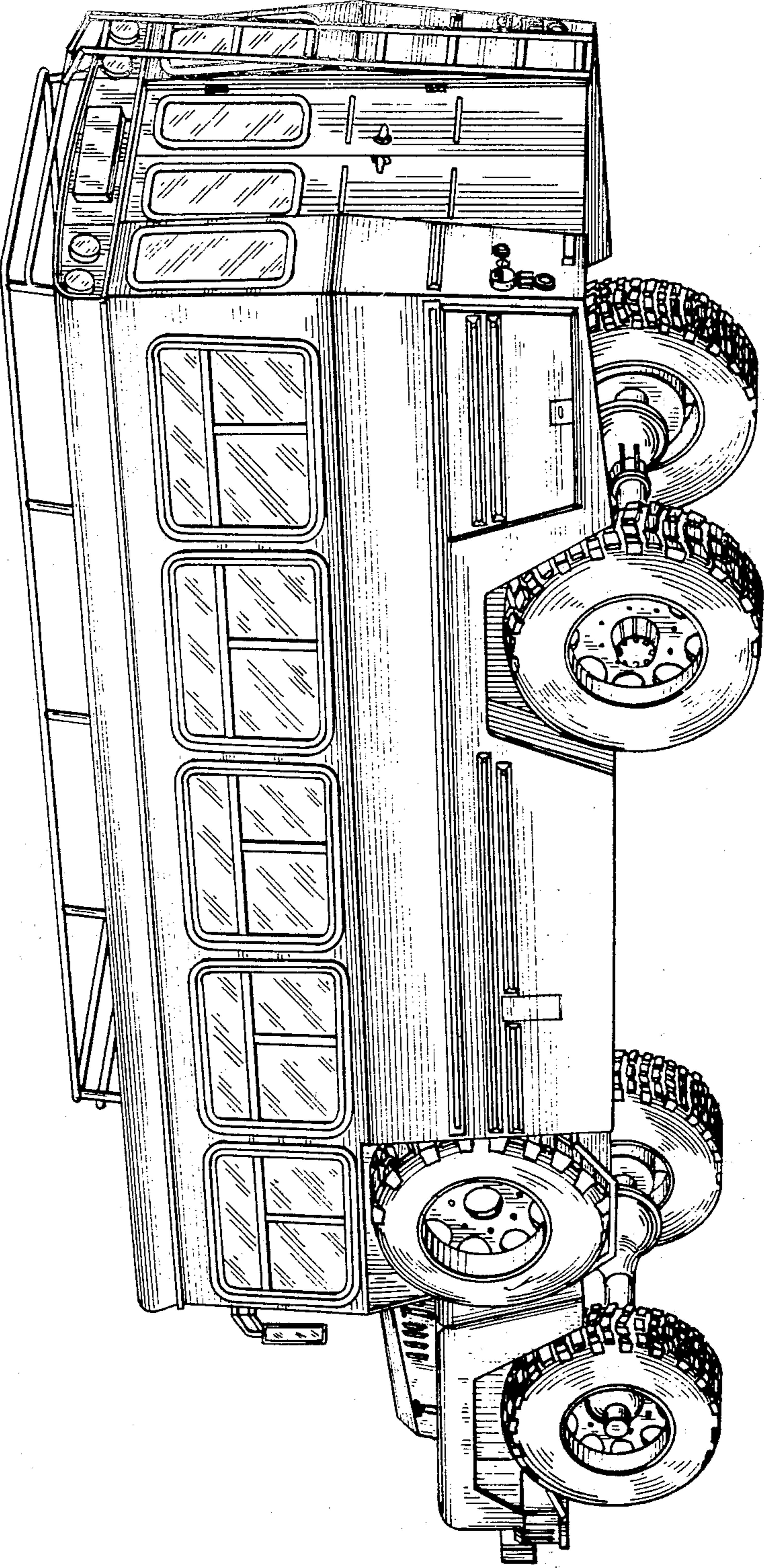

Fig. 4

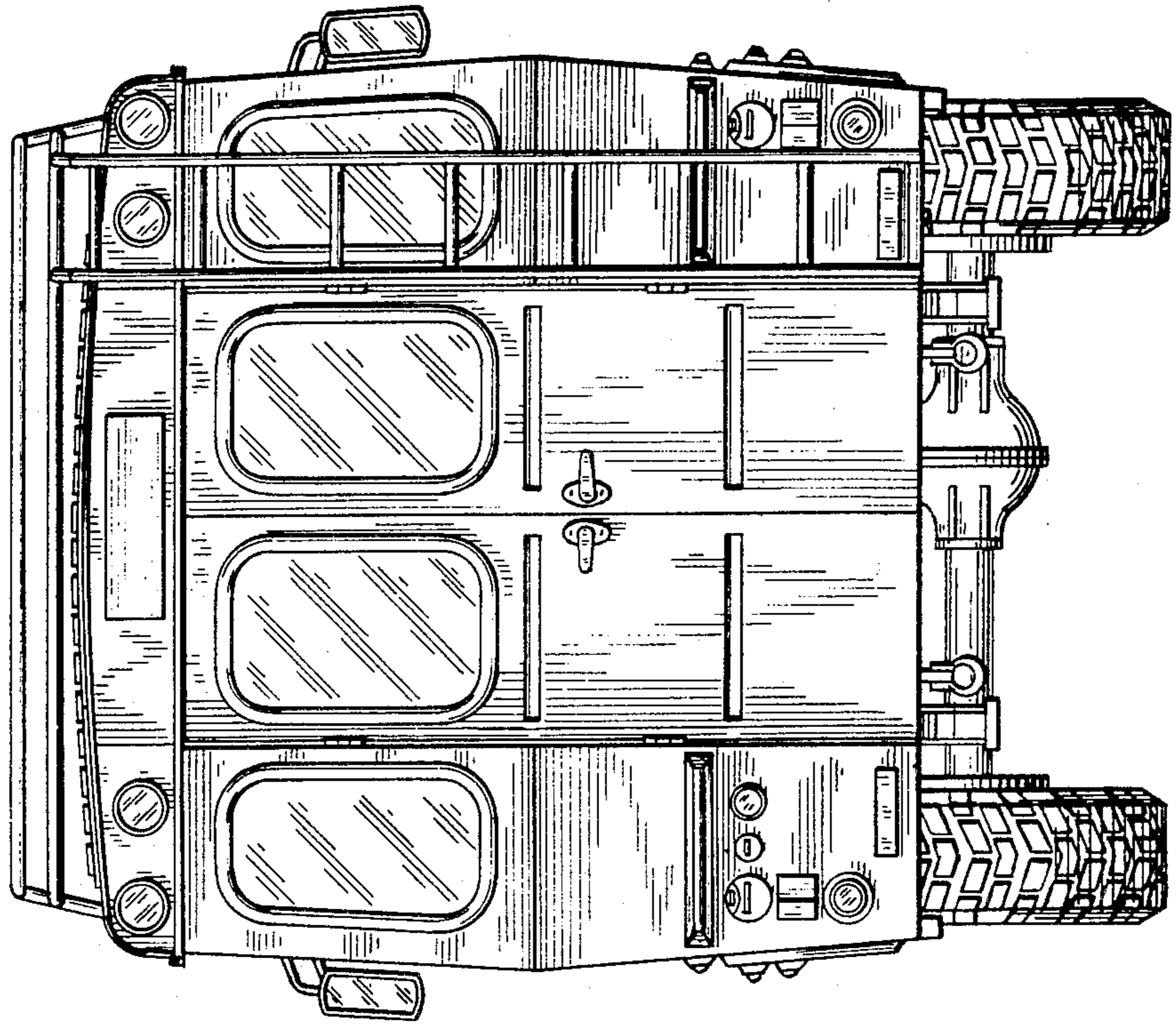

Fig. 3

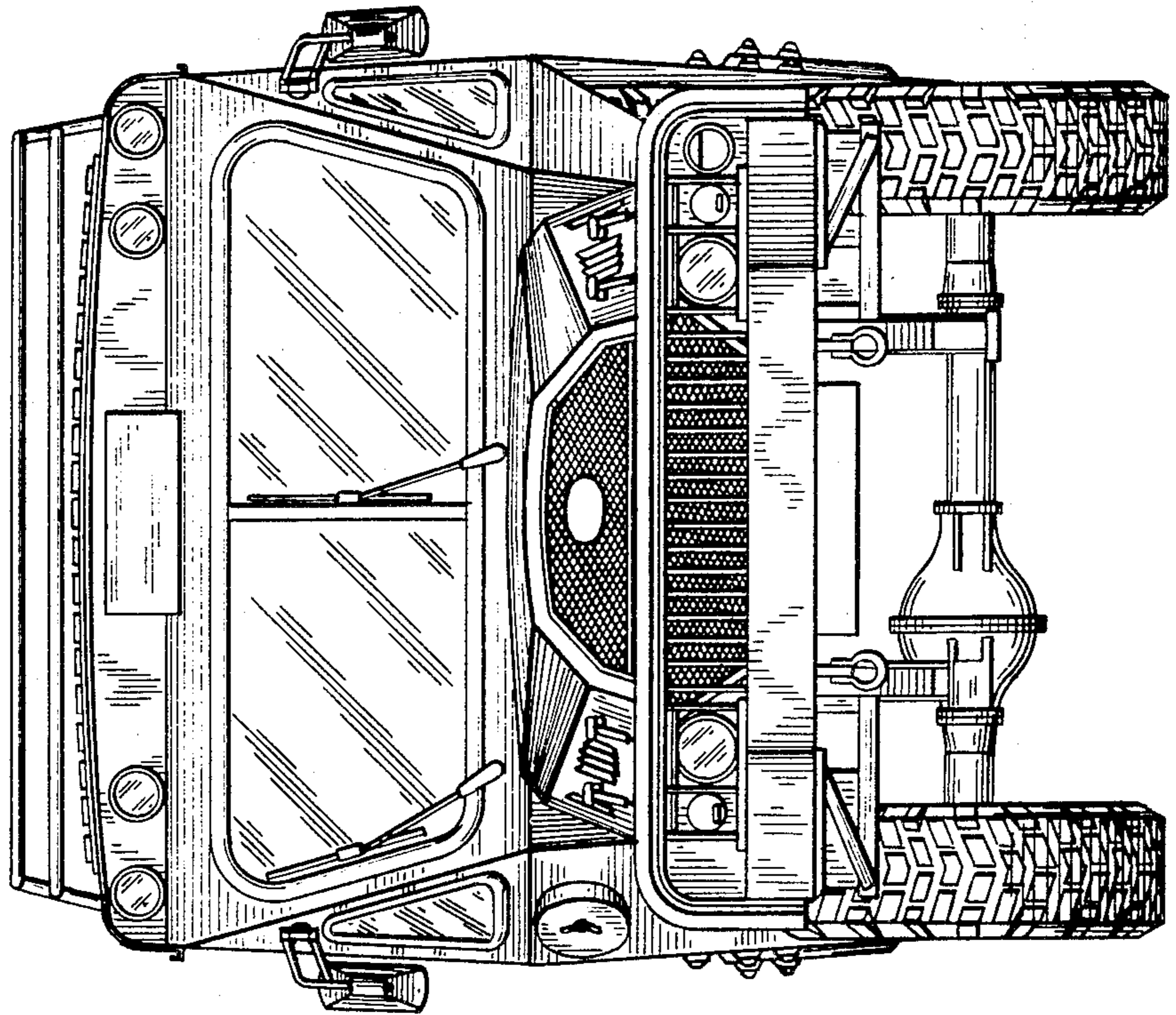

Fig. 5

