

[54] MODEL AIRPLANE

[76] Inventor: Yasuaki Ninomiya, Suite 5-101 Tamaplaza 20 Utsukushigaoka, 1-chome, Midoriku, Yokohama, Kanagawa, Japan

[**] Term: 14 Years

[21] Appl. No.: 590,762

[22] Filed: Mar. 19, 1984

[30] Foreign Application Priority Data

Nov. 22, 1983 [JP] Japan 58-50990

[52] U.S. Cl. D21/89

[58] Field of Search D21/82, 85, 86, 87, D21/88, 89; 244/153 R, 153 A, 154; D12/319, 321, 333

[56] References Cited

U.S. PATENT DOCUMENTS

D. 162,707 4/1951 Benson D21/89

D. 166,440 4/1952 Benson D21/86
D. 242,866 12/1976 Ditto D21/87
2,060,213 11/1936 Hippen et al. D21/87
4,235,040 11/1980 Trowbridge 273/426

Primary Examiner—Charles A. Rademaker
Attorney, Agent, or Firm—Spensley Horn Jubas & Lubitz

[57] CLAIM

The ornamental design for a model airplane, as shown.

DESCRIPTION

FIG. 1 is a right side perspective view of a model airplane showing my new design;
FIG. 2 is a bottom perspective view;
FIG. 3 is a front elevational view;
FIG. 4 is a rear elevational view;
FIG. 5 is a side elevational view thereof;
FIG. 6 is a side elevational view of the side opposite that shown in FIG. 5
FIG. 7 is a top plan view; and
FIG. 8 is a bottom plan view.

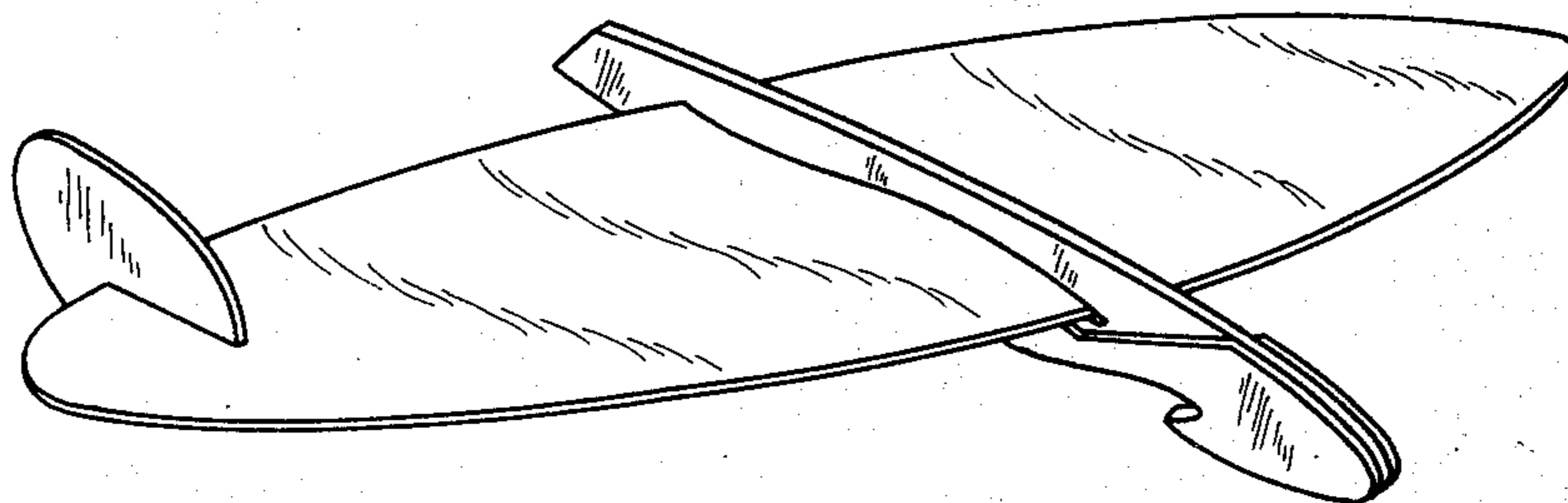

FIG. 1

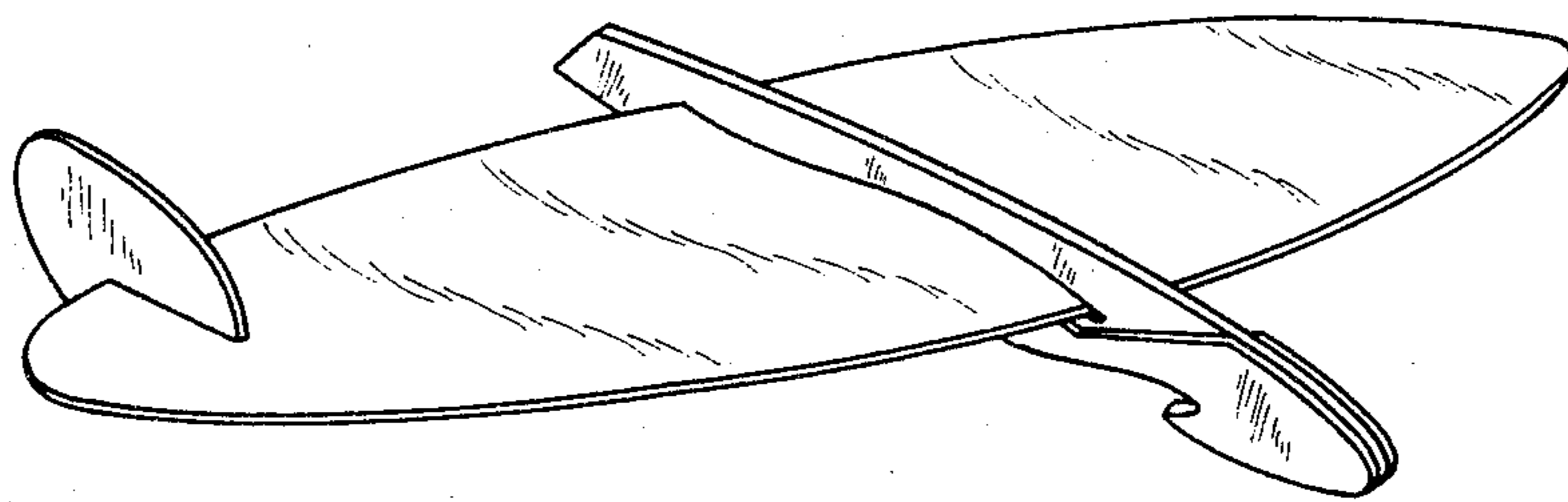

FIG. 2

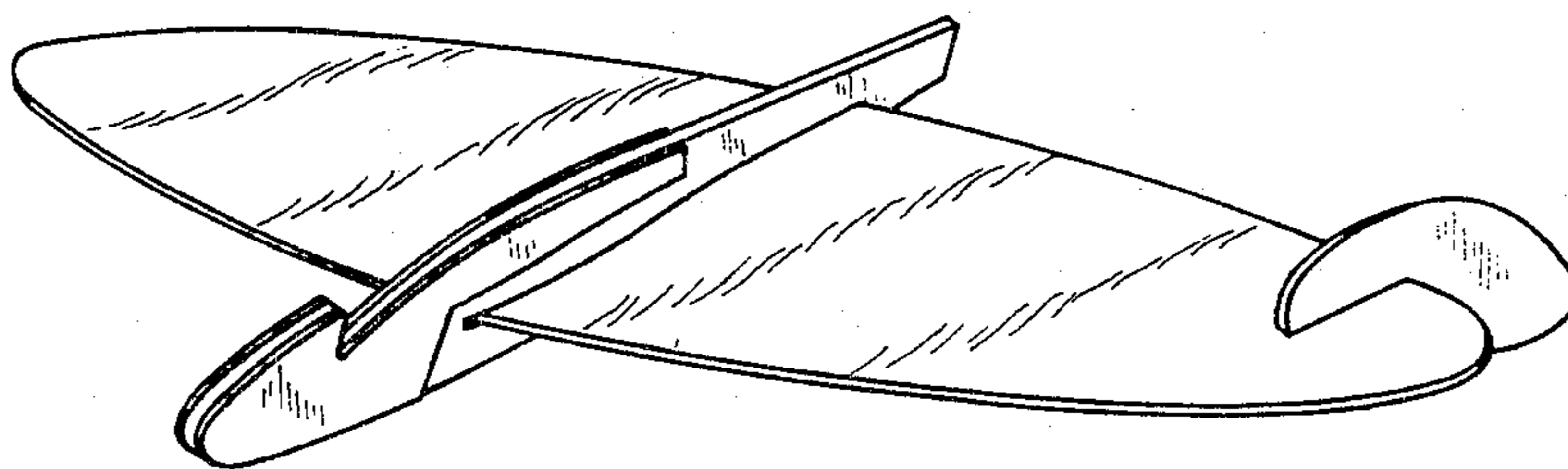

FIG. 3

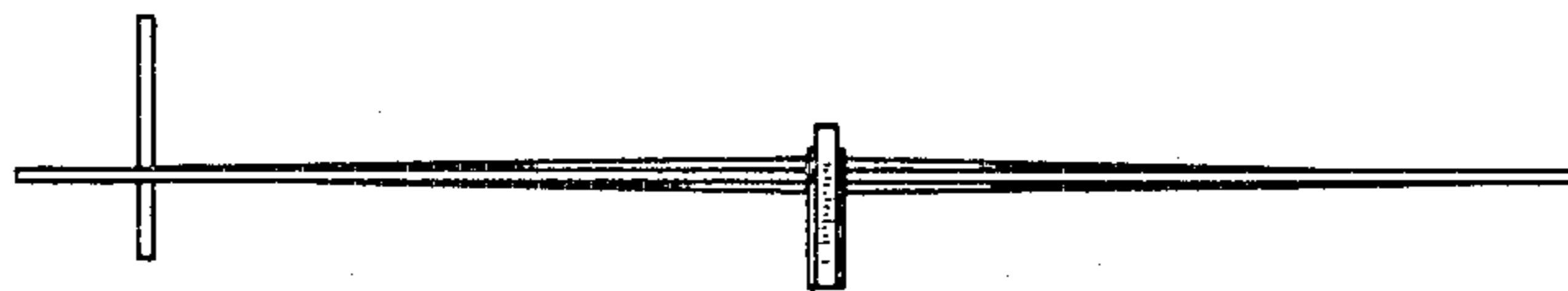

FIG. 4

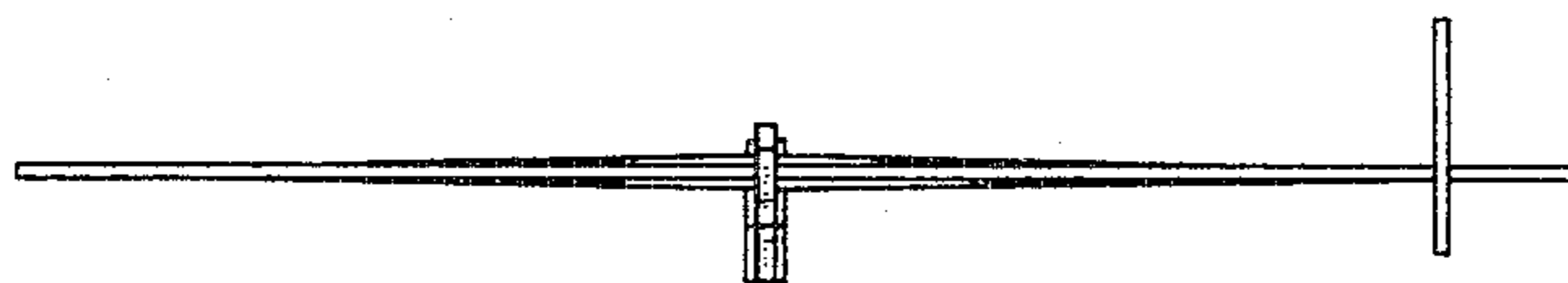

FIG. 5

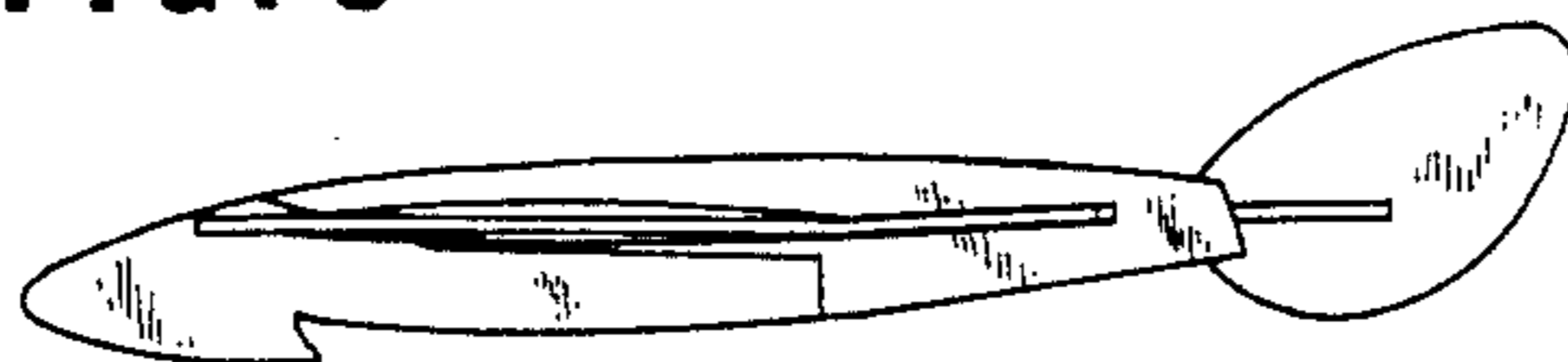

FIG. 6

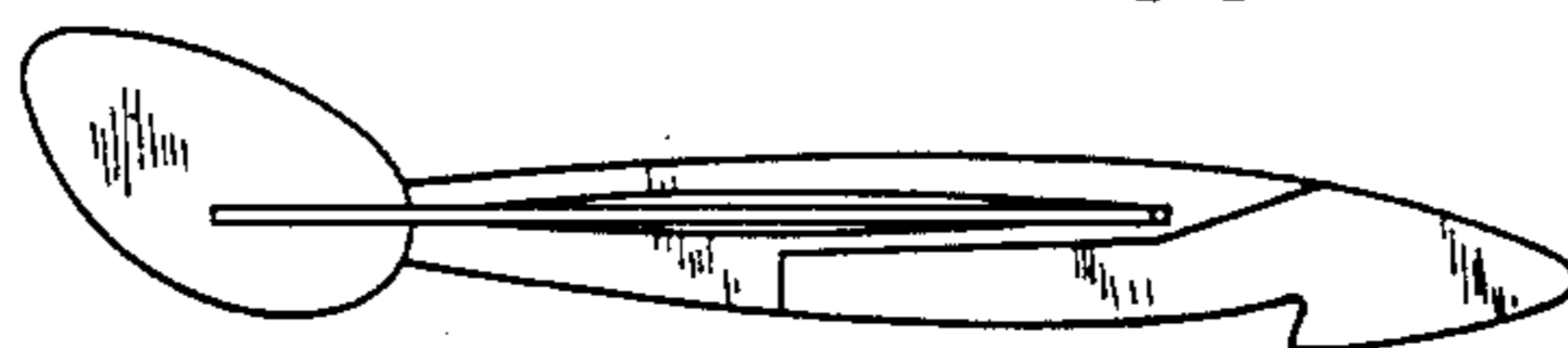

FIG. 7

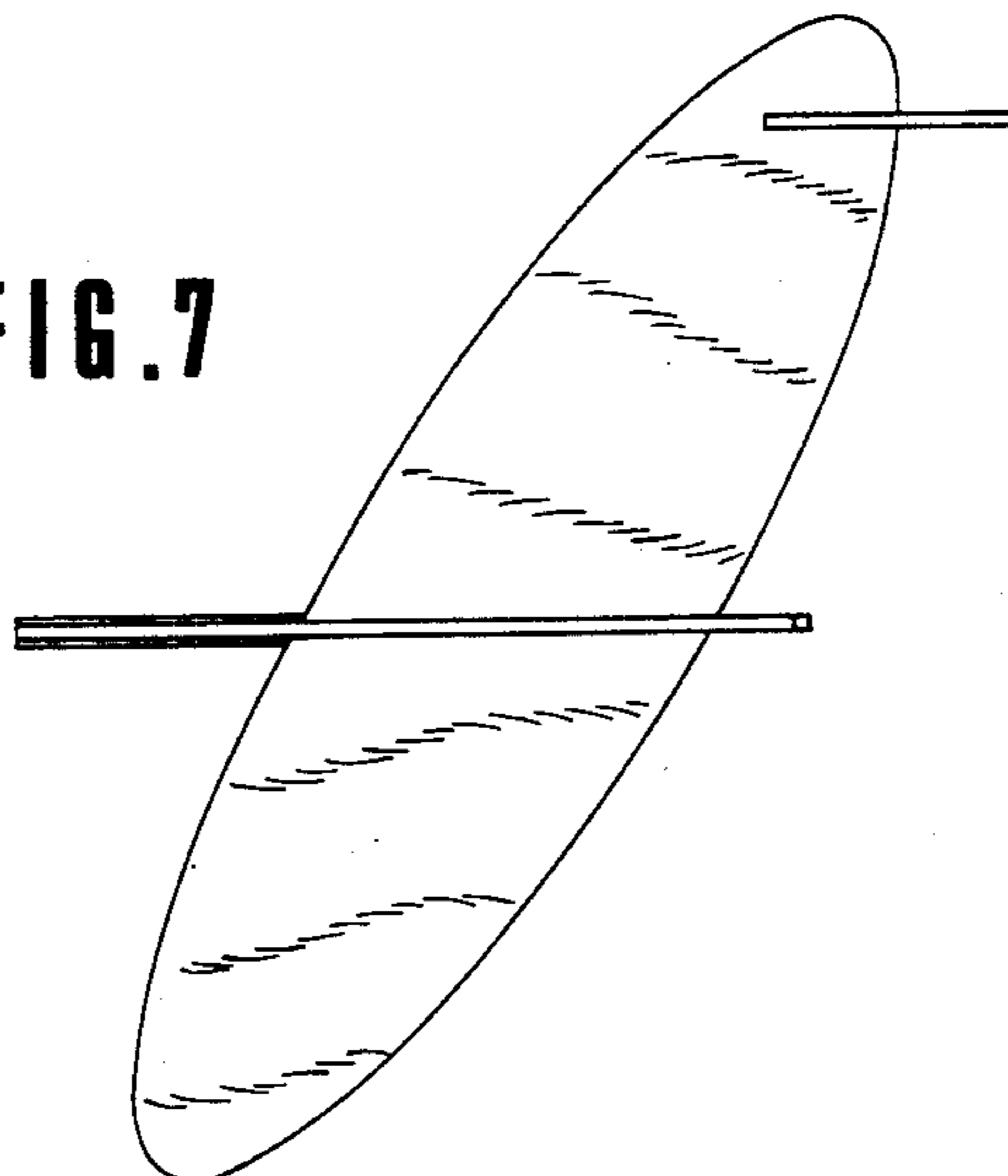

FIG. 8

