

[54] CLAMP

[75] Inventors: George L. Steck, Dayton; Raymond E. Steck, Miamisburg; Laurence D. Steck, Dayton, all of Ohio

[73] Assignee: Steck Manufacturing Company, Inc., Dayton, Ohio

[\*\*] Term: 14 Years

[21] Appl. No.: 563,108

[22] Filed: Dec. 19, 1983

[52] U.S. Cl. .... D8/394

[58] Field of Search ..... D8/382, 394; 403/385, 403/388; 52/721; 33/288; 248/228

[56] References Cited

U.S. PATENT DOCUMENTS

D. 174,150	3/1955	Weller et al. ....	D8/394
885,001	4/1908	Cameron .	
1,230,441	6/1917	Stevens .	
1,536,361	5/1925	Tomes .	
2,722,440	11/1955	Barton .....	403/385
2,765,139	10/1956	White .....	248/228
3,486,726	12/1969	Kindorf et al. ....	248/228
3,556,452	1/1971	Ramsey .....	248/228

3,589,659	6/1971	Larkin .....	248/228
3,743,228	7/1973	Drab .....	248/228
3,869,804	3/1975	Friend .....	33/288
3,936,023	2/1976	Clifton .....	248/228
4,329,784	5/1982	Bjork .....	33/180 AT
4,397,437	8/1983	Madej .....	D8/394

FOREIGN PATENT DOCUMENTS

0144279	1/1952	Australia .....	403/385
2220648	10/1974	France .....	403/385
0454315	1/1950	Italy .....	403/385
0093784	12/1938	Sweden .....	403/385

Primary Examiner—B. J. Bullock

[57] CLAIM

The ornamental design for a clamp, as shown and described.

DESCRIPTION

FIG. 1 is a perspective view of the clamp showing our new design;  
 FIG. 2 is a left end elevational view thereof;  
 FIG. 3 is a front elevational view thereof;  
 FIG. 4 is a top plan view thereof;  
 FIG. 5 is a rear elevational view thereof;  
 FIG. 6 is a bottom plan view thereof.

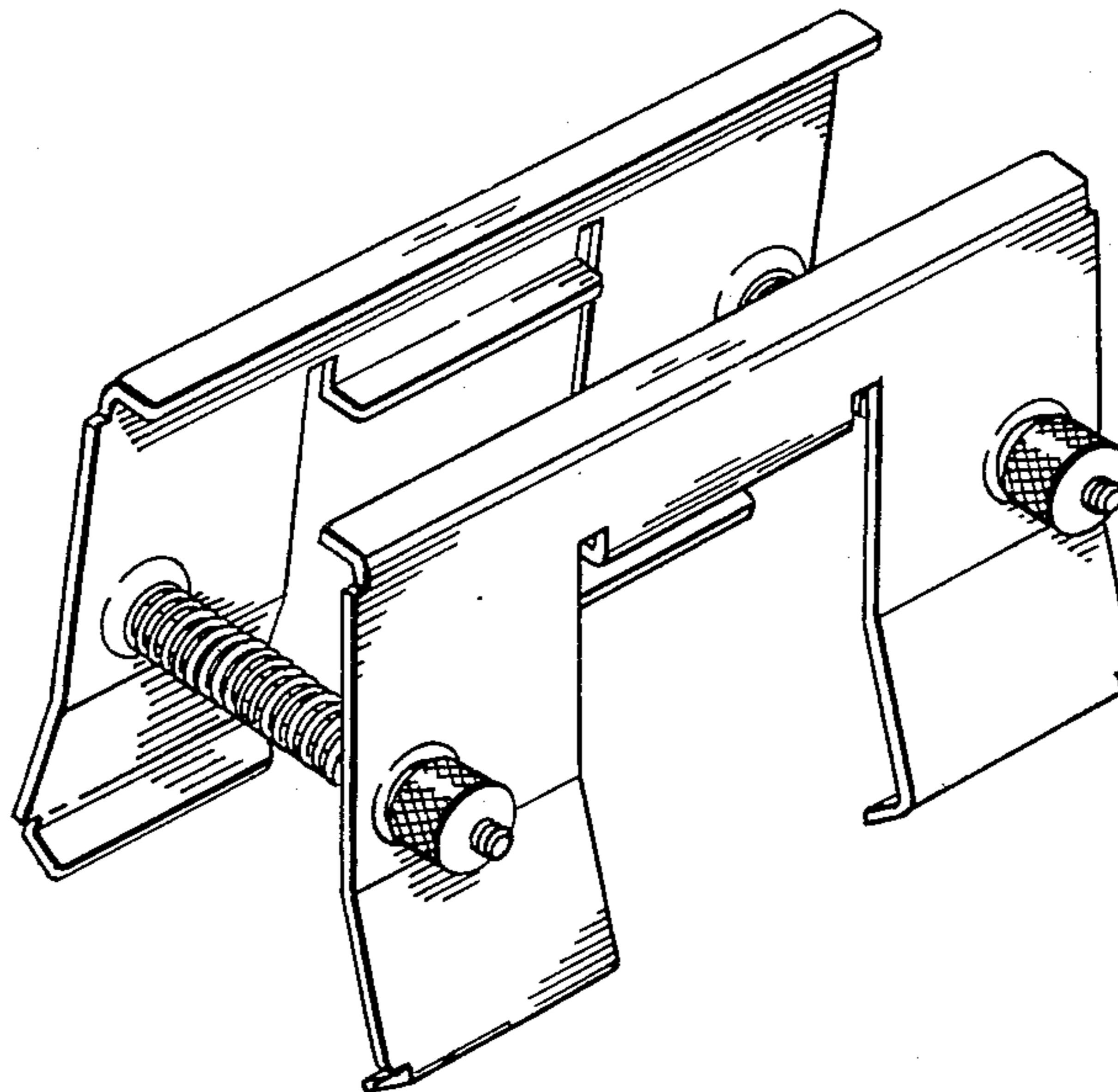

FIG-1

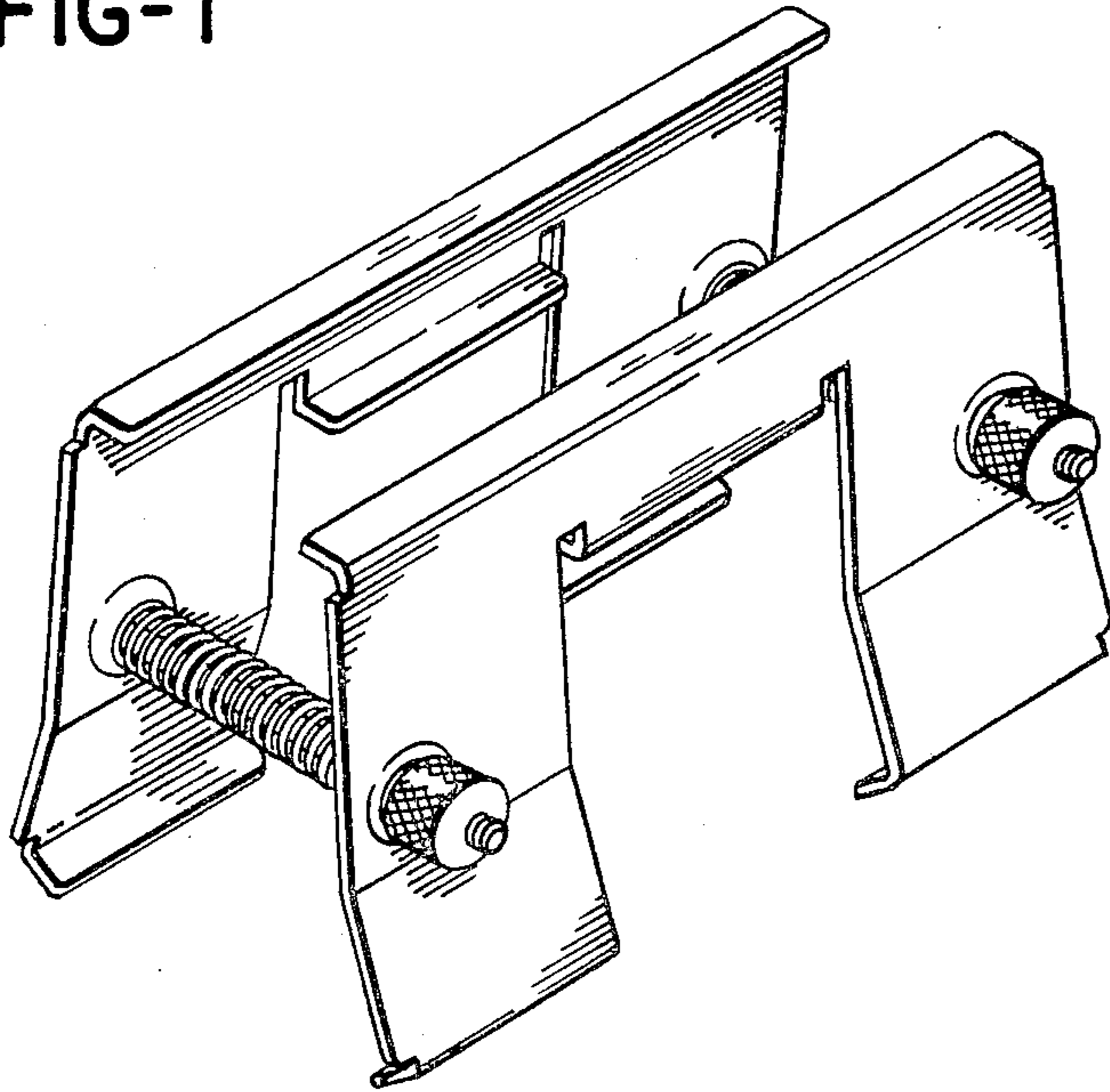

FIG-2

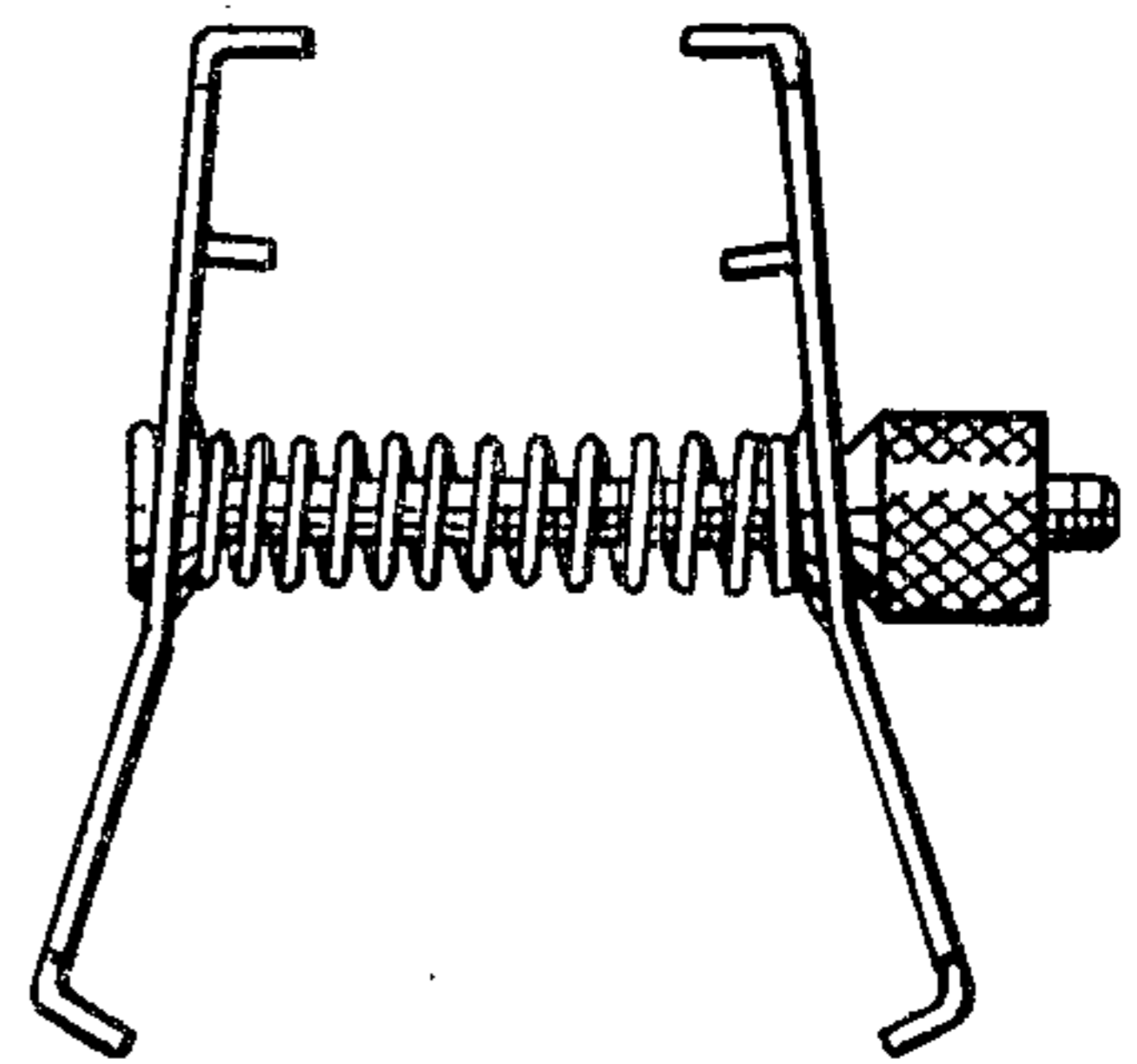

FIG-3

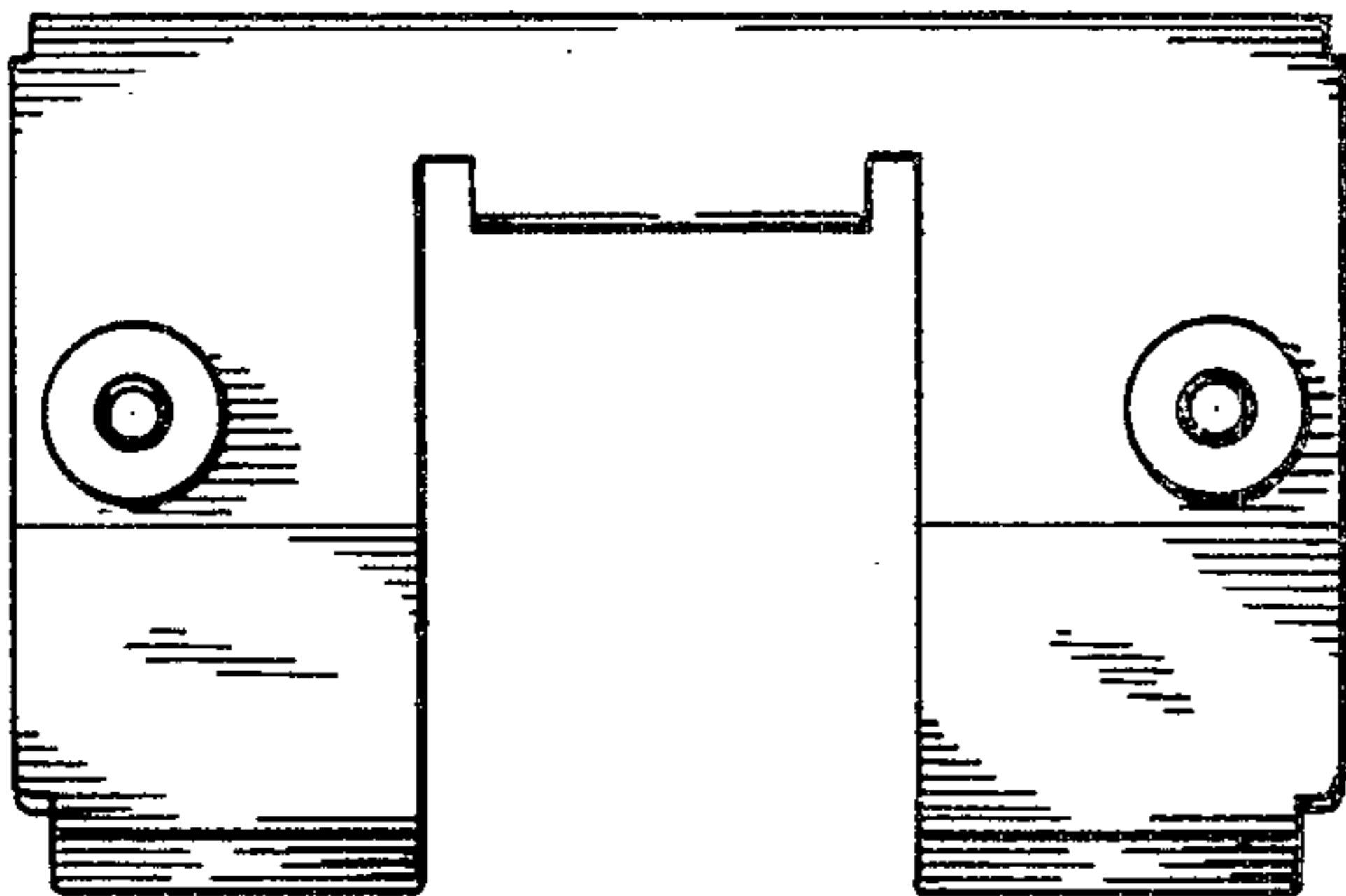

FIG-5

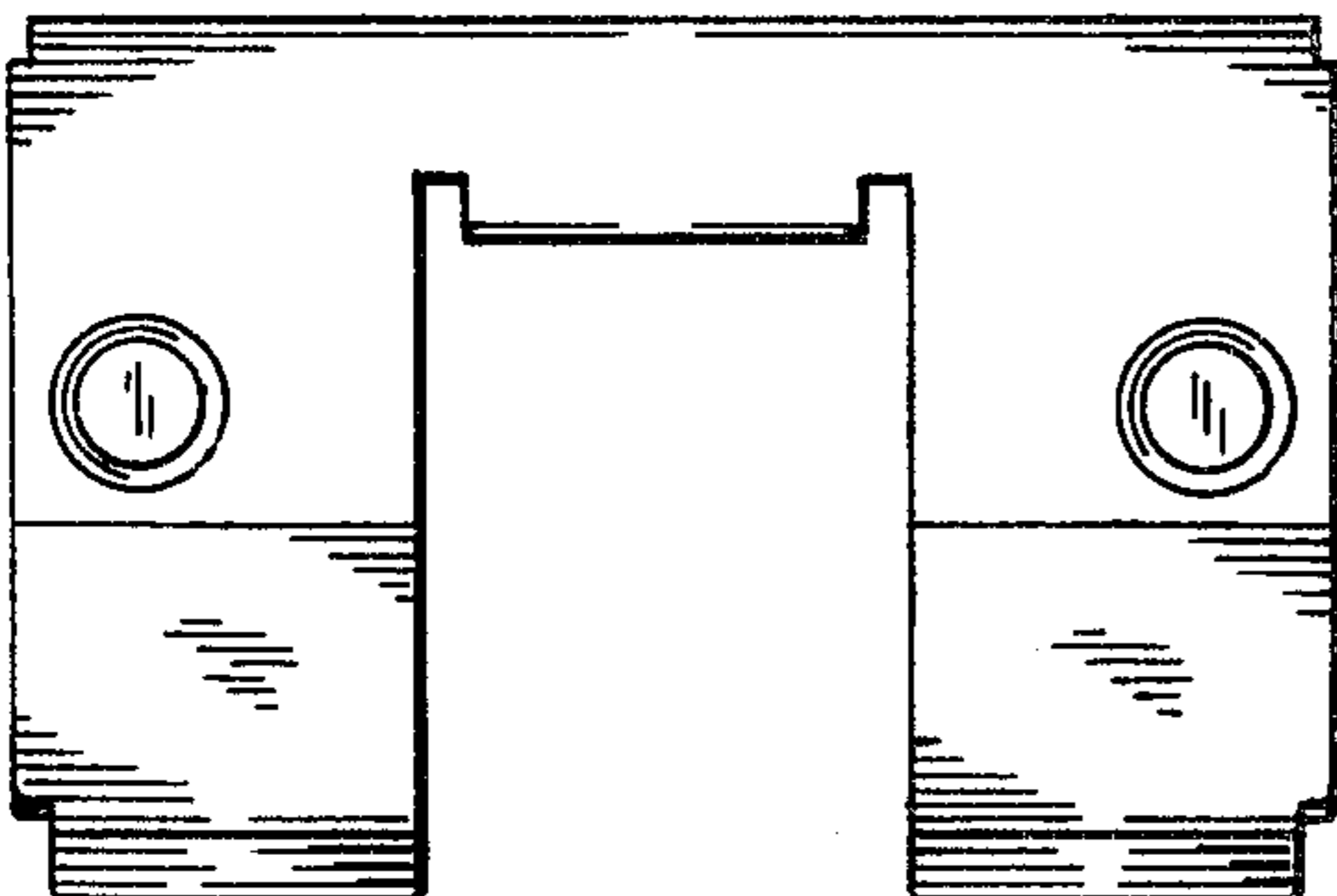

FIG-4

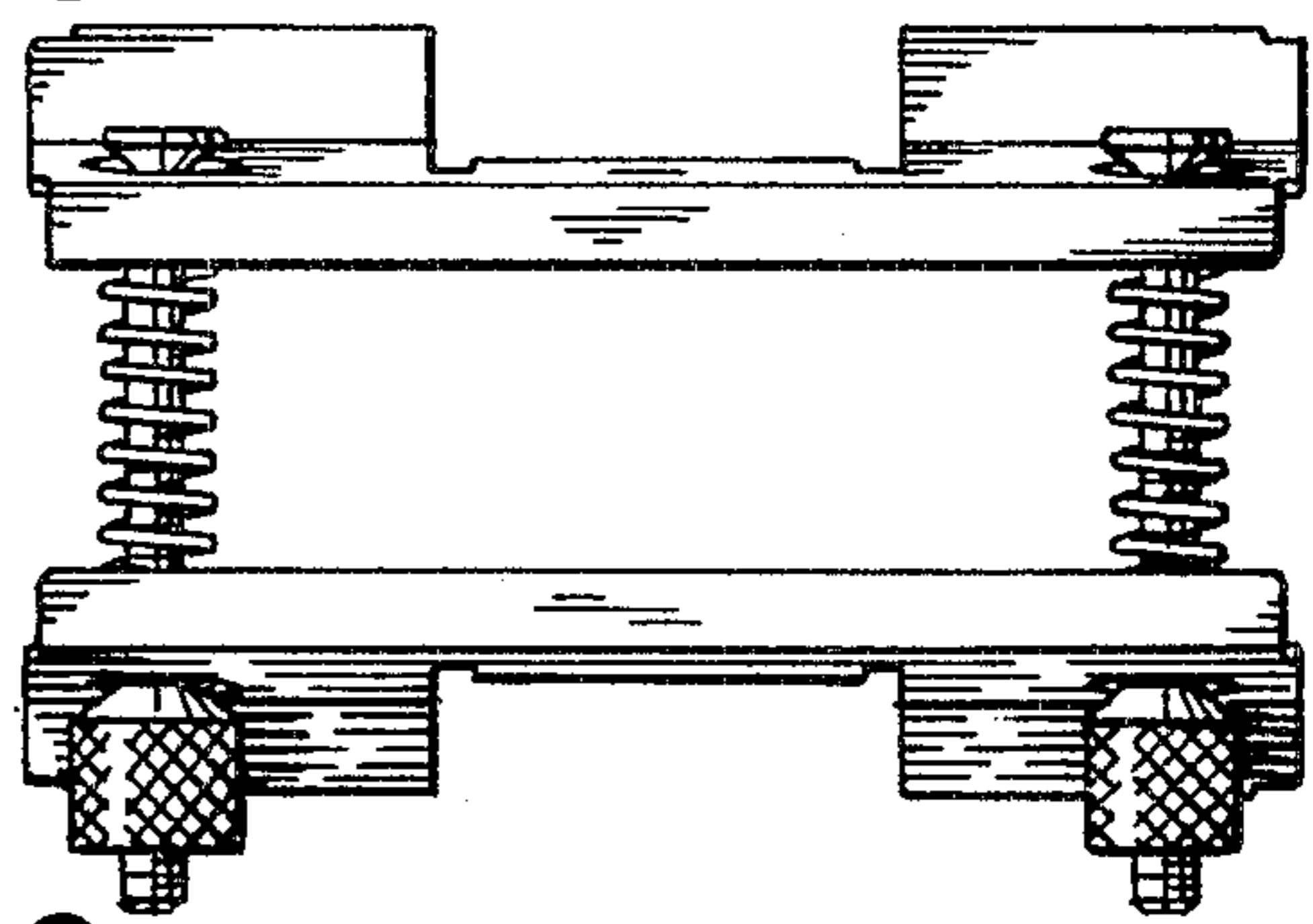

FIG-6

