

[54] CONTAINER FOR REAGENT USE IN CHEMICAL CLINICAL ANALYSIS

[75] Inventor: Marlo R. Andersen, Veradale, Wash.

[73] Assignee: Instrumentation Laboratory, Lexington, Mass.

[**] Term: 14 Years

[21] Appl. No.: 599,514

[22] Filed: Apr. 12, 1984

[52] U.S. Cl. D24/56; D32/25

[58] Field of Search D32/25; 206/524.5, 530, 206/540, 524.1; 220/DIG. 13, DIG. 14; D24/8, 56, 99

[56] References Cited

U.S. PATENT DOCUMENTS

- D. 190,027 4/1961 Carroll et al. D24/56
- D. 234,025 12/1974 Potter D24/8

1,440,046 12/1922 Ziplinsky 206/540
3,172,130 3/1965 Lange 220/DIG. 13

Primary Examiner—Wallace R. Burke
Assistant Examiner—Ruth E. Takemoto
Attorney, Agent, or Firm—Lowell H. McCarter

[57] CLAIM

The ornamental design for a container for reagent use in chemical clinical analysis, as shown.

DESCRIPTION

FIG. 1 is a perspective view of a container for reagent use in chemical clinical analysis showing my new design;
FIG. 2 is a top plan view thereof;
FIG. 3 is a front elevational view thereof;
FIG. 4 is a side elevational view thereof, the opposite side being a mirror image;
FIG. 5 is a rear elevational view thereof; and
FIG. 6 is a bottom plan view thereof.

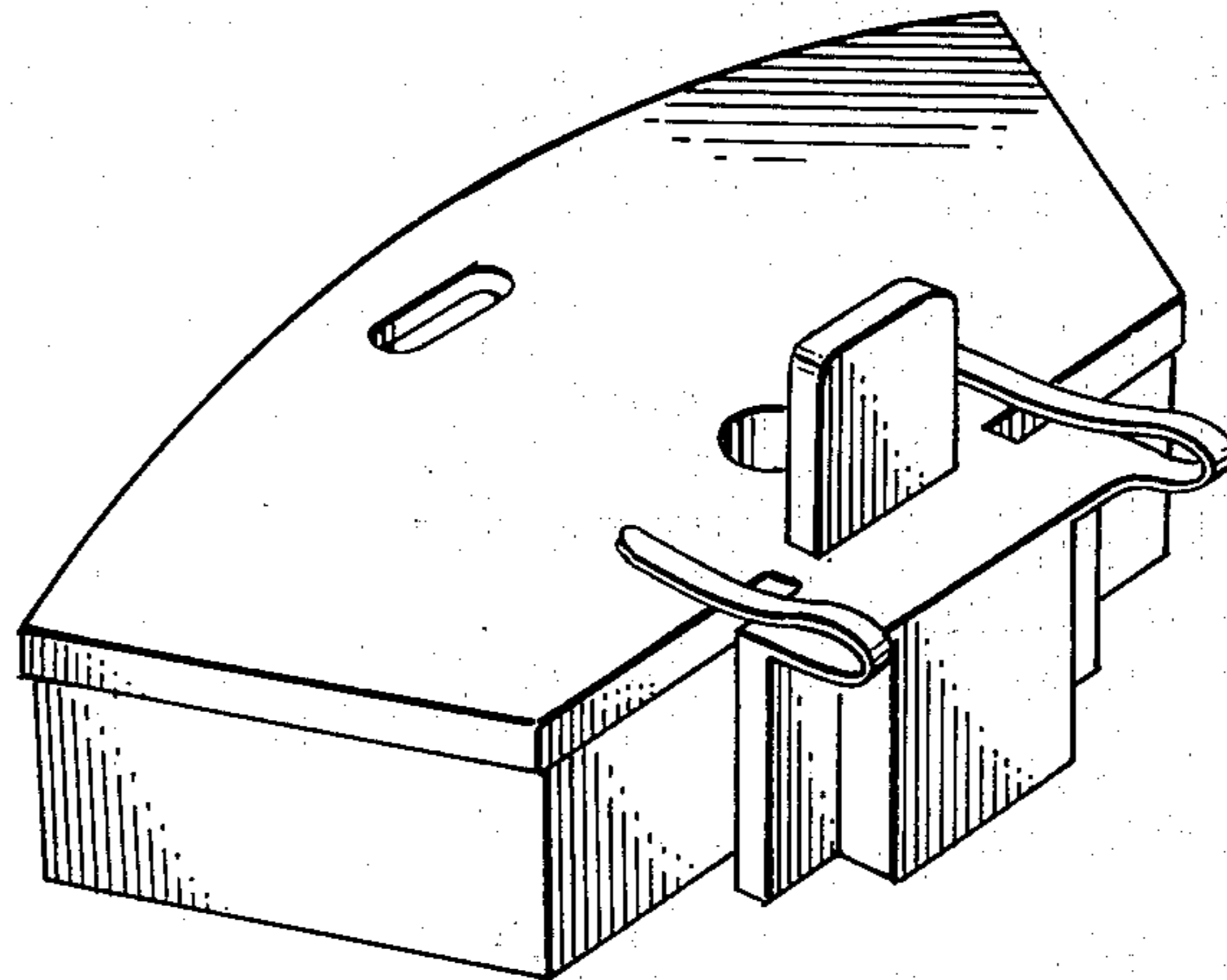

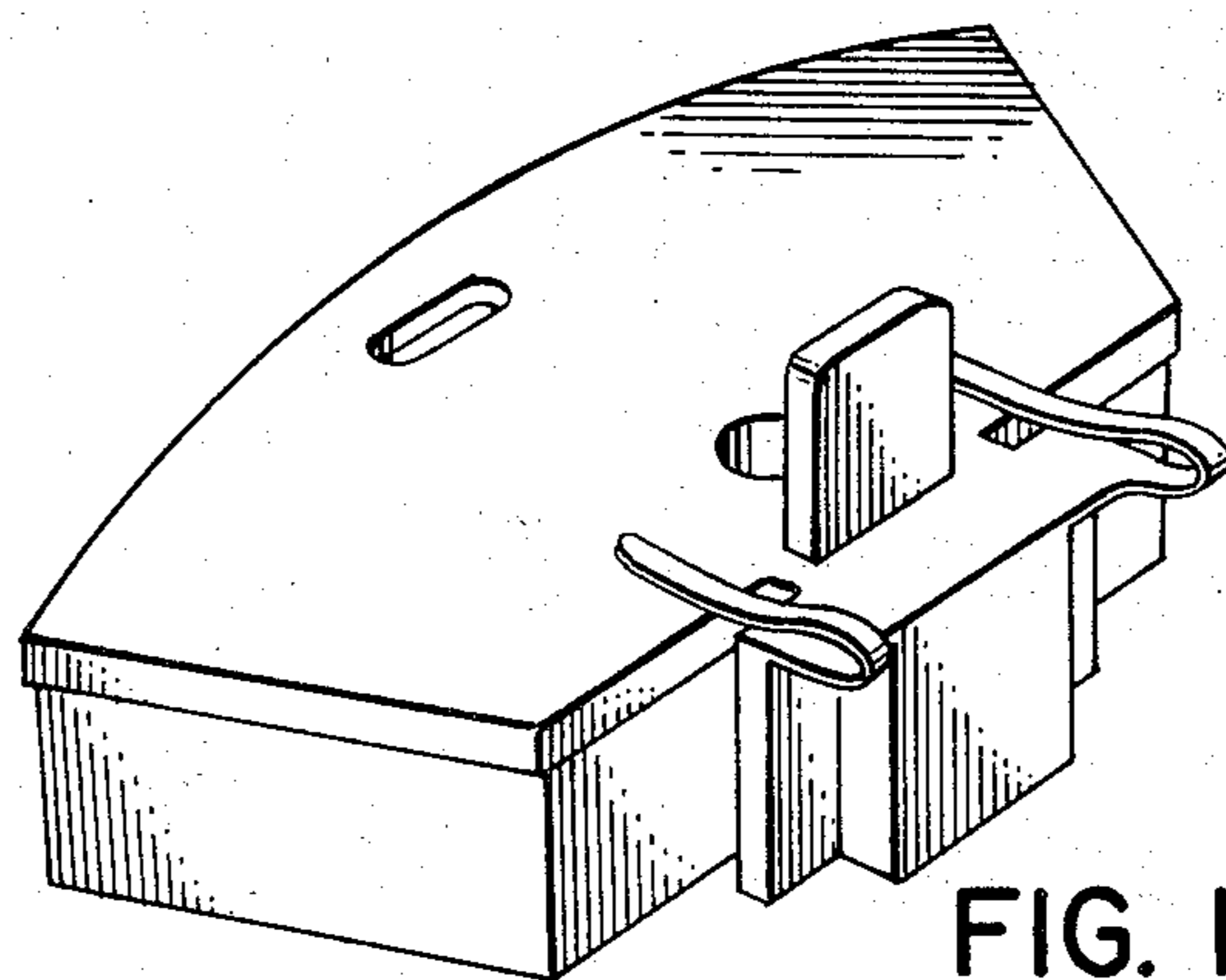

FIG. 1

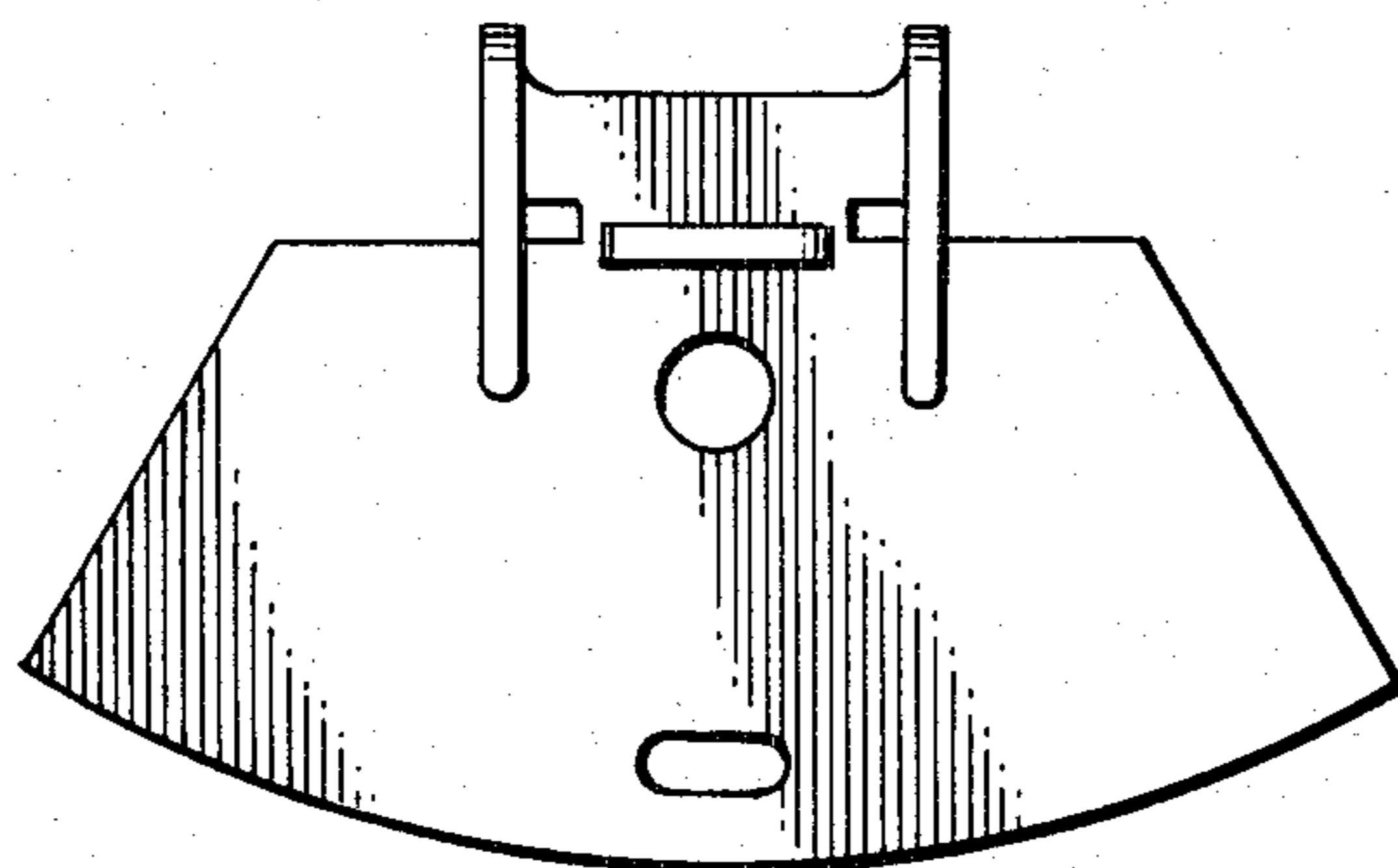

FIG. 2

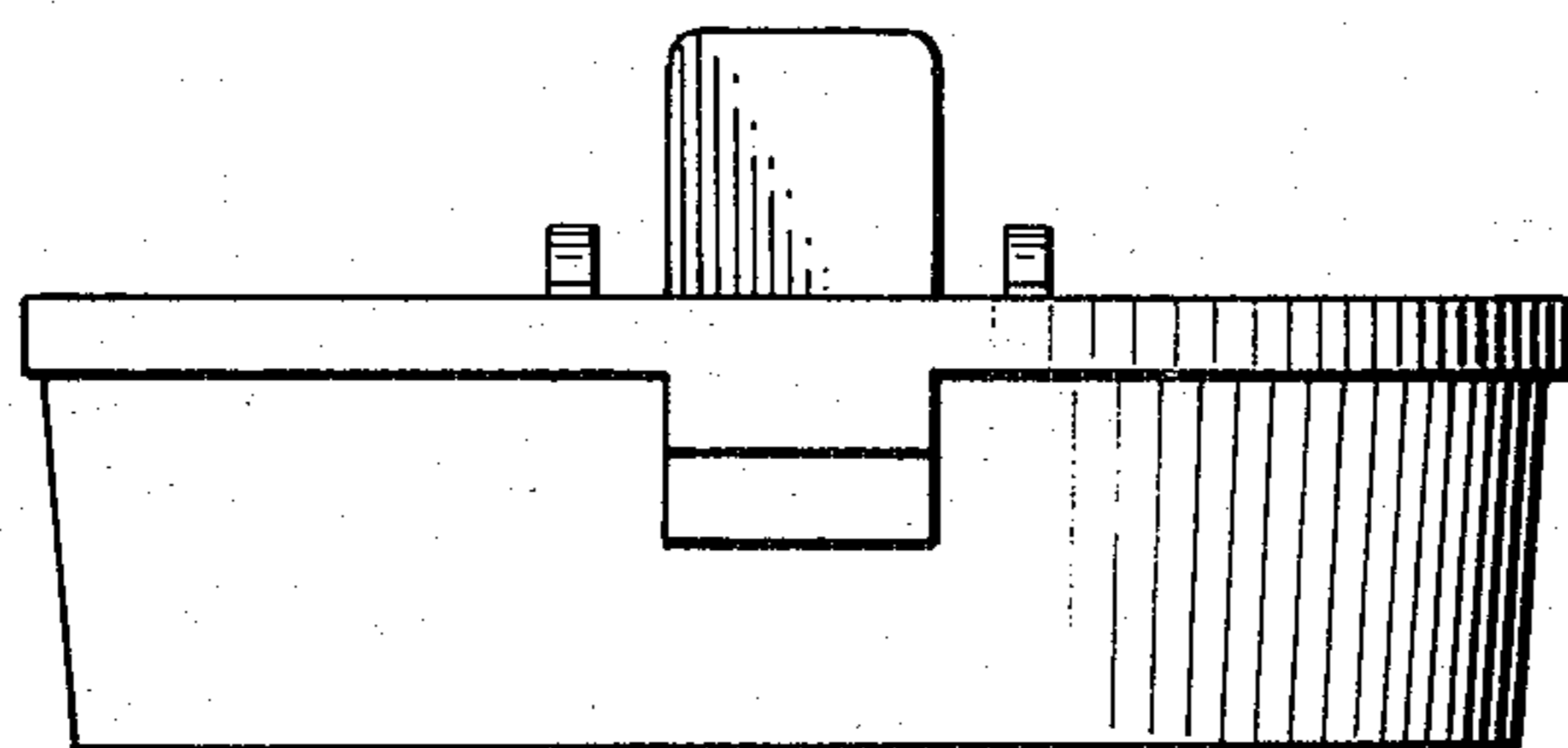

FIG. 3

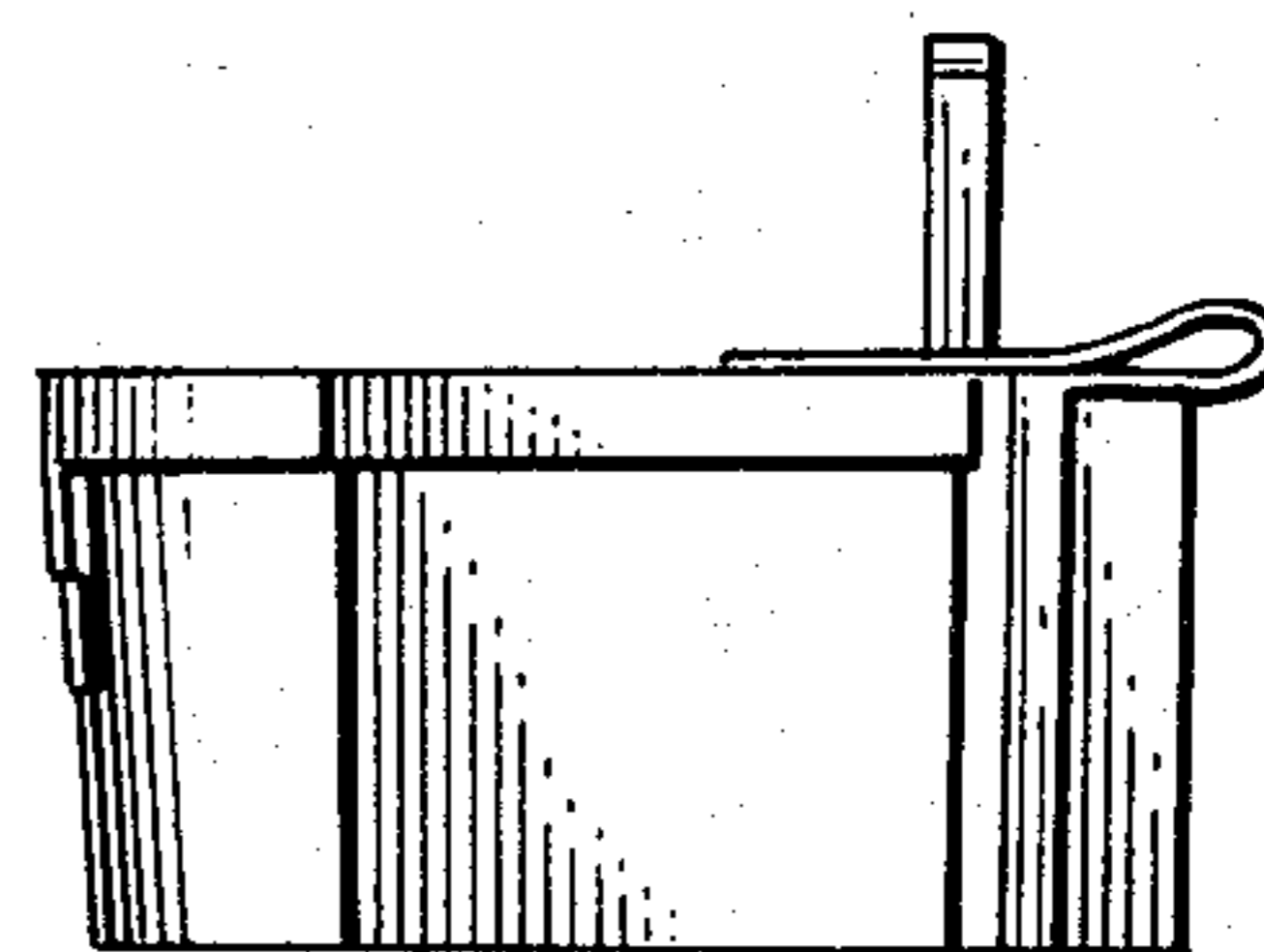

FIG. 4

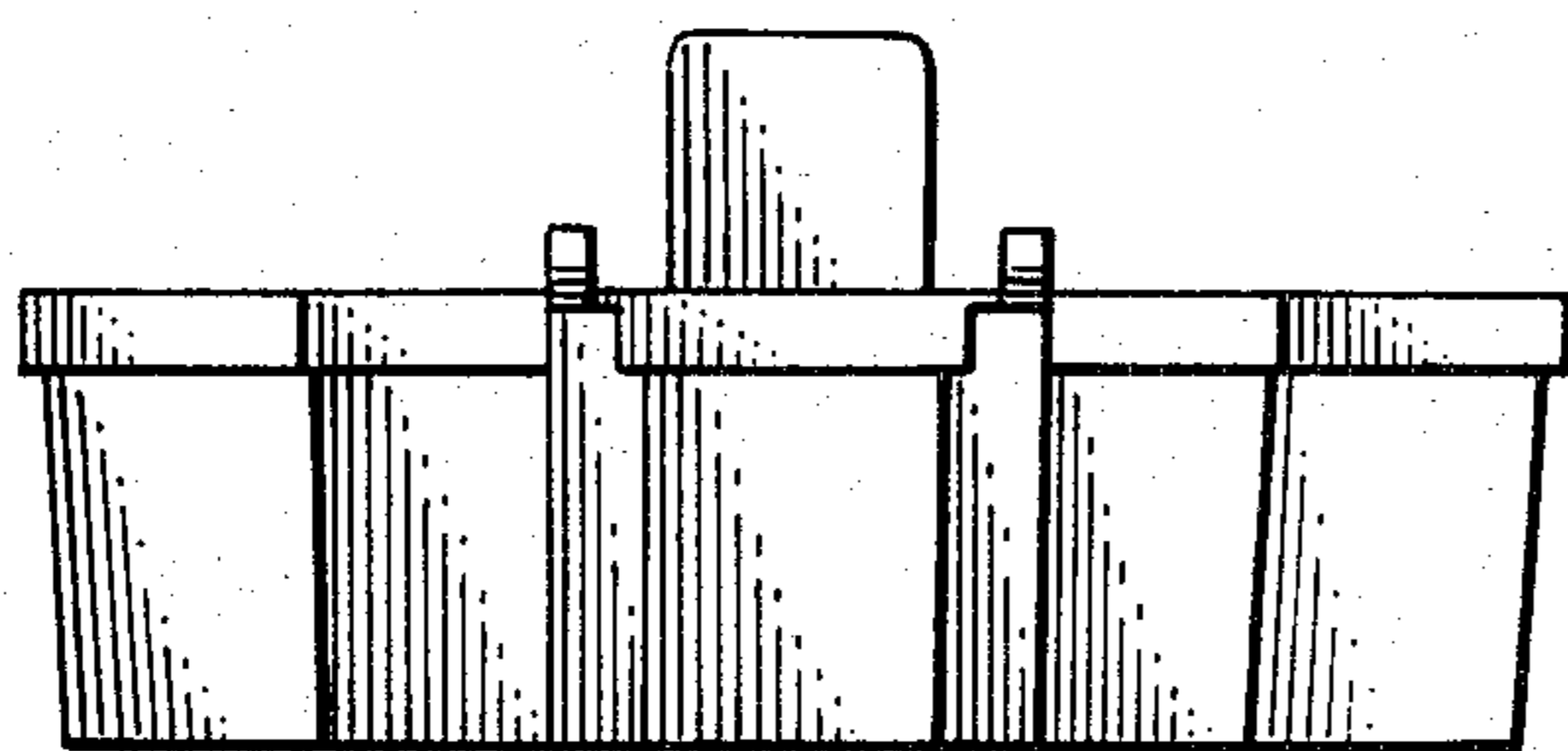

FIG. 5

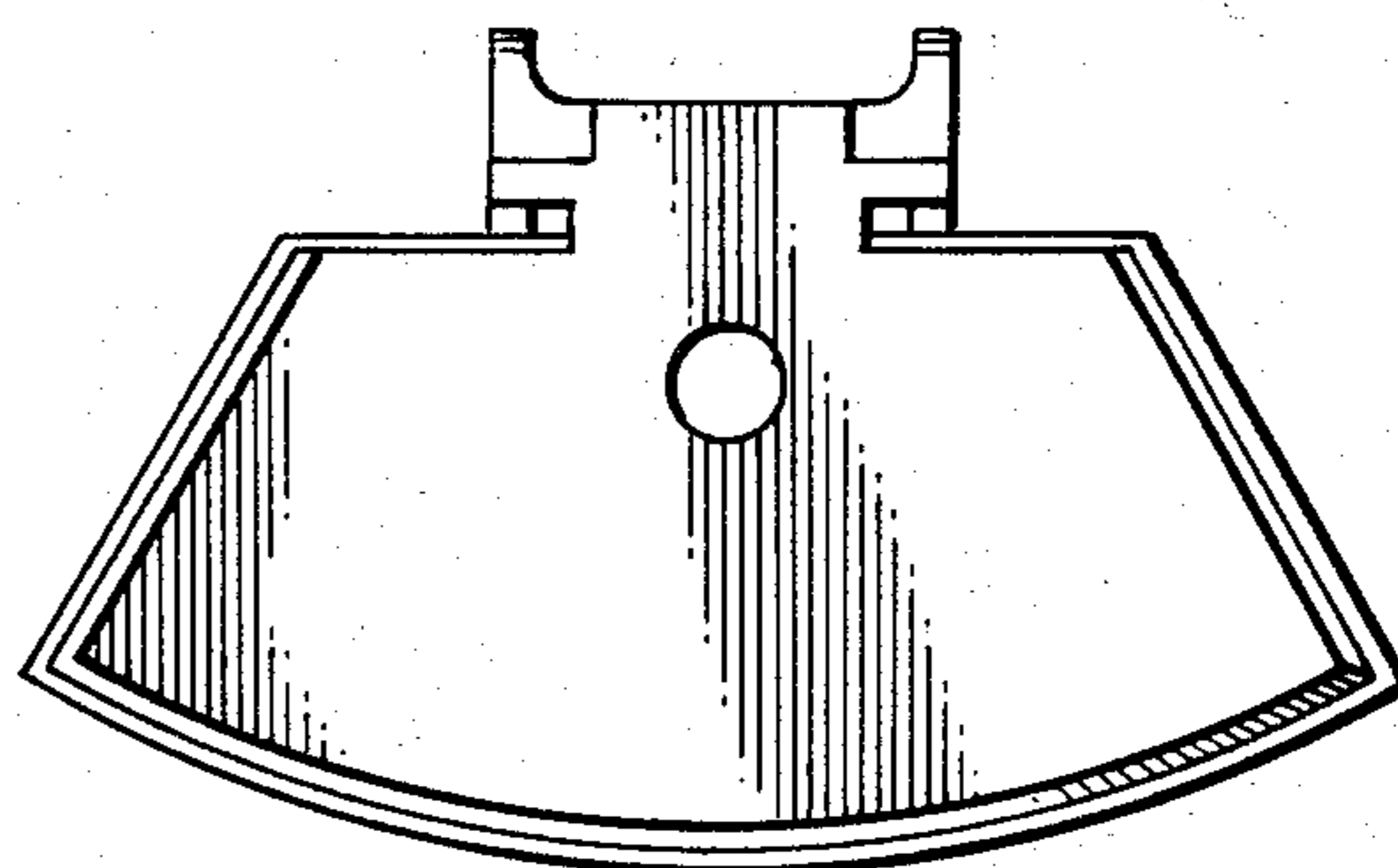

FIG. 6