

# United States Patent [19]

Tamura et al.

[11] Patent Number: **Des. 286,761**

[45] Date of Patent: **\*\* Nov. 18, 1986**

[54] **MOTOR TRICYCLE**

[75] Inventors: **Gen Tamura; Akira Watanabe**, both of Tokyo; **Yukinori Kawaguchi**, Saitama, all of Japan

[73] Assignee: **Honda Giken Kogyo Kabushiki Kaisha**, Tokyo, Japan

[\*\*] Term: **14 Years**

[21] Appl. No.: **660,460**

[22] Filed: **Oct. 12, 1984**

[30] **Foreign Application Priority Data**

Apr. 18, 1984 [JP] Japan ..... 59-15629

[52] U.S. Cl. .... **D12/110**

[58] Field of Search ..... D12/110; 180/215, 217, 180/210

[56] **References Cited**

**U.S. PATENT DOCUMENTS**

D. 267,792 2/1983 Ohba ..... D12/110

D. 269,261 6/1983 Mikado ..... D12/110  
D. 276,035 10/1984 Ito et al. .... D12/110

**OTHER PUBLICATIONS**

J. C. Whitney Catalog No. 426B, ©1982, p. 281, Rear Carrier B for ATVS, top of page.

*Primary Examiner*—James M. Gandy  
*Attorney, Agent, or Firm*—Lyon & Lyon

[57] **CLAIM**

The ornamental design for a motor tricycle, as shown and described.

**DESCRIPTION**

FIG. 1 is a top perspective view of a motor tricycle showing our new design;

FIG. 2 is a bottom perspective view thereof;

FIG. 3 is a front perspective view thereof;

FIG. 4 is a side elevation view of the right side thereof;

FIG. 5 is a side elevation view of the left side thereof;

FIG. 6 is a back perspective view thereof; and

FIG. 7 is an oblique view principally illustrating the left side thereof.

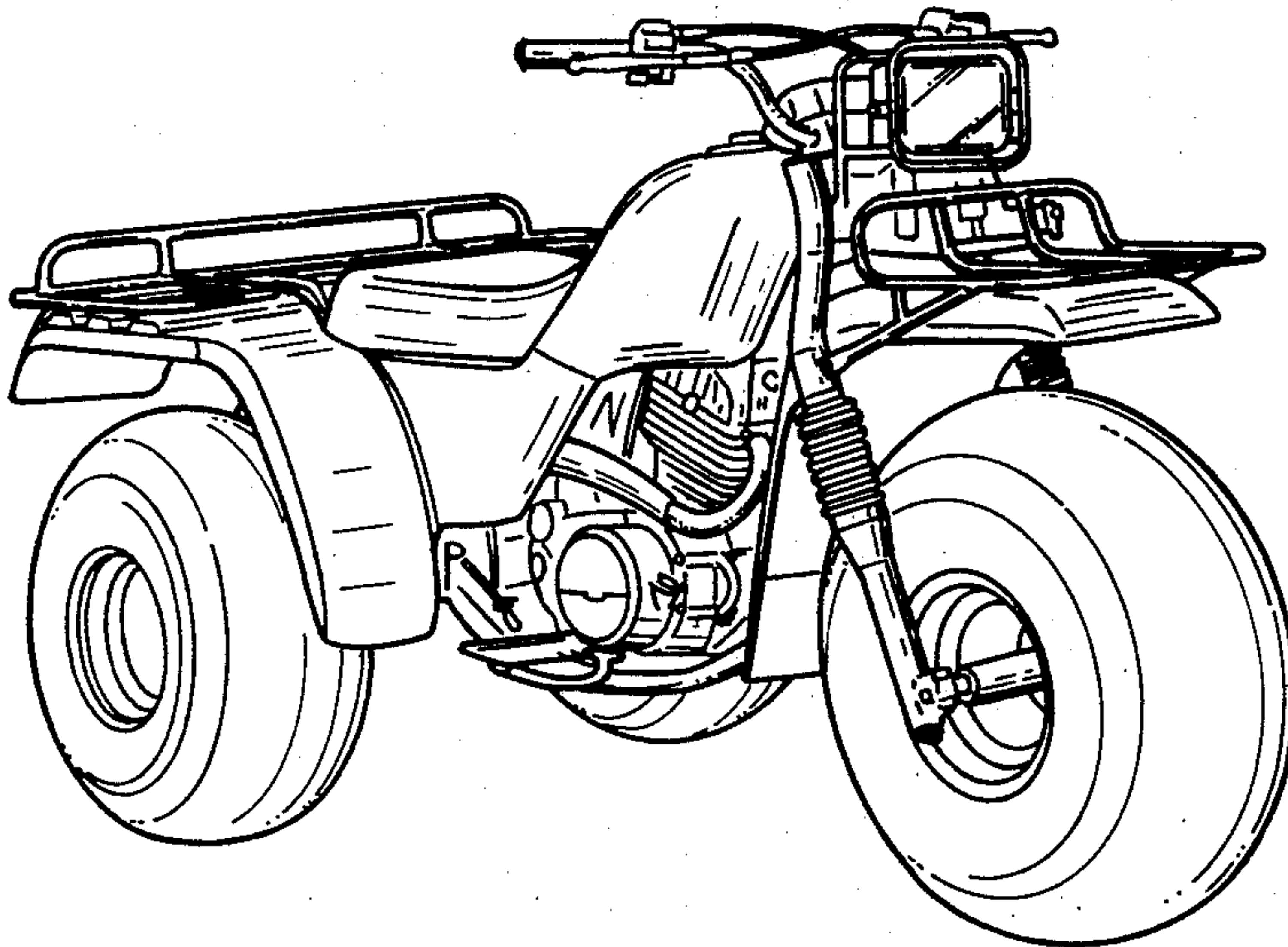

FIG. 1.

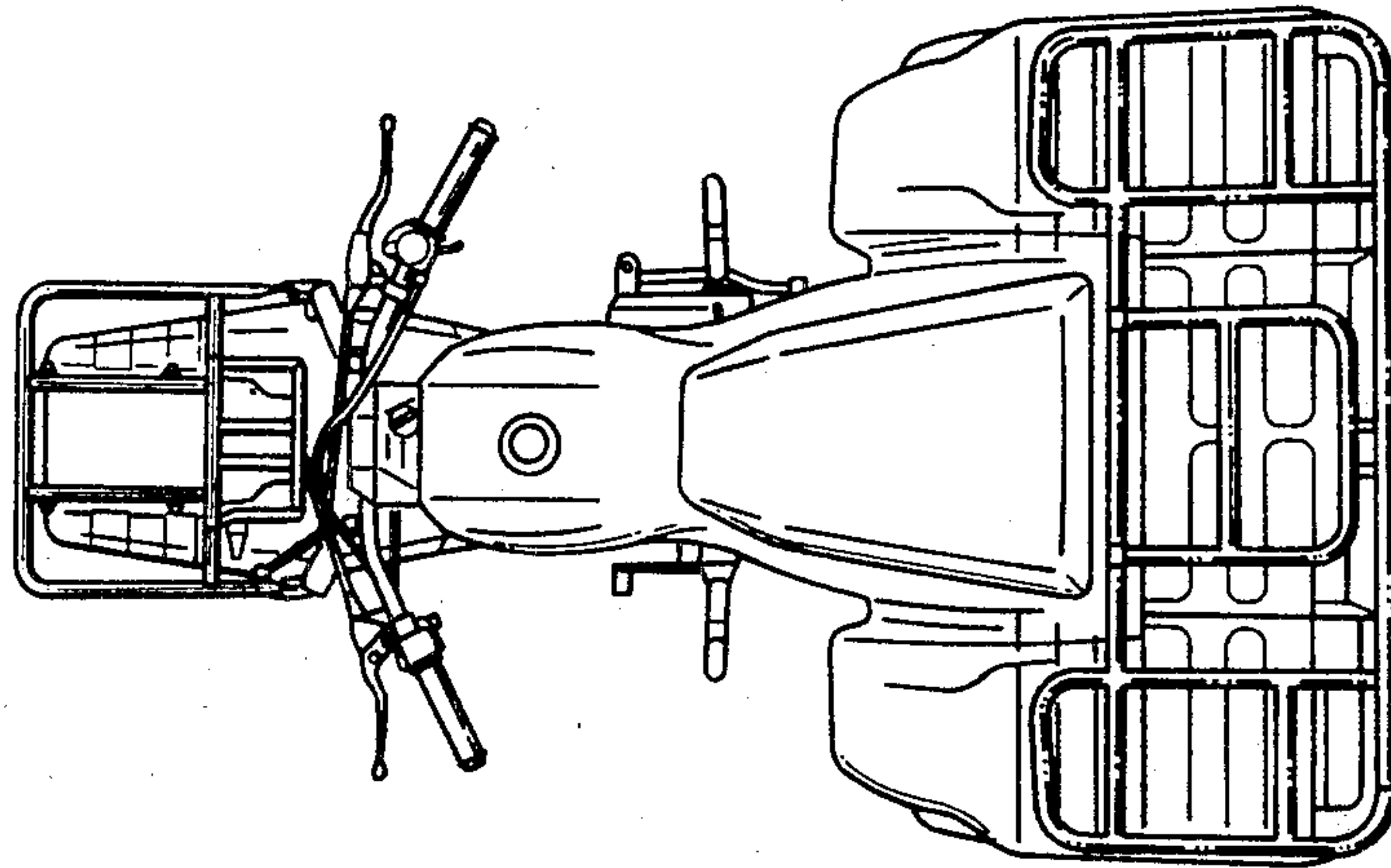

FIG. 2.

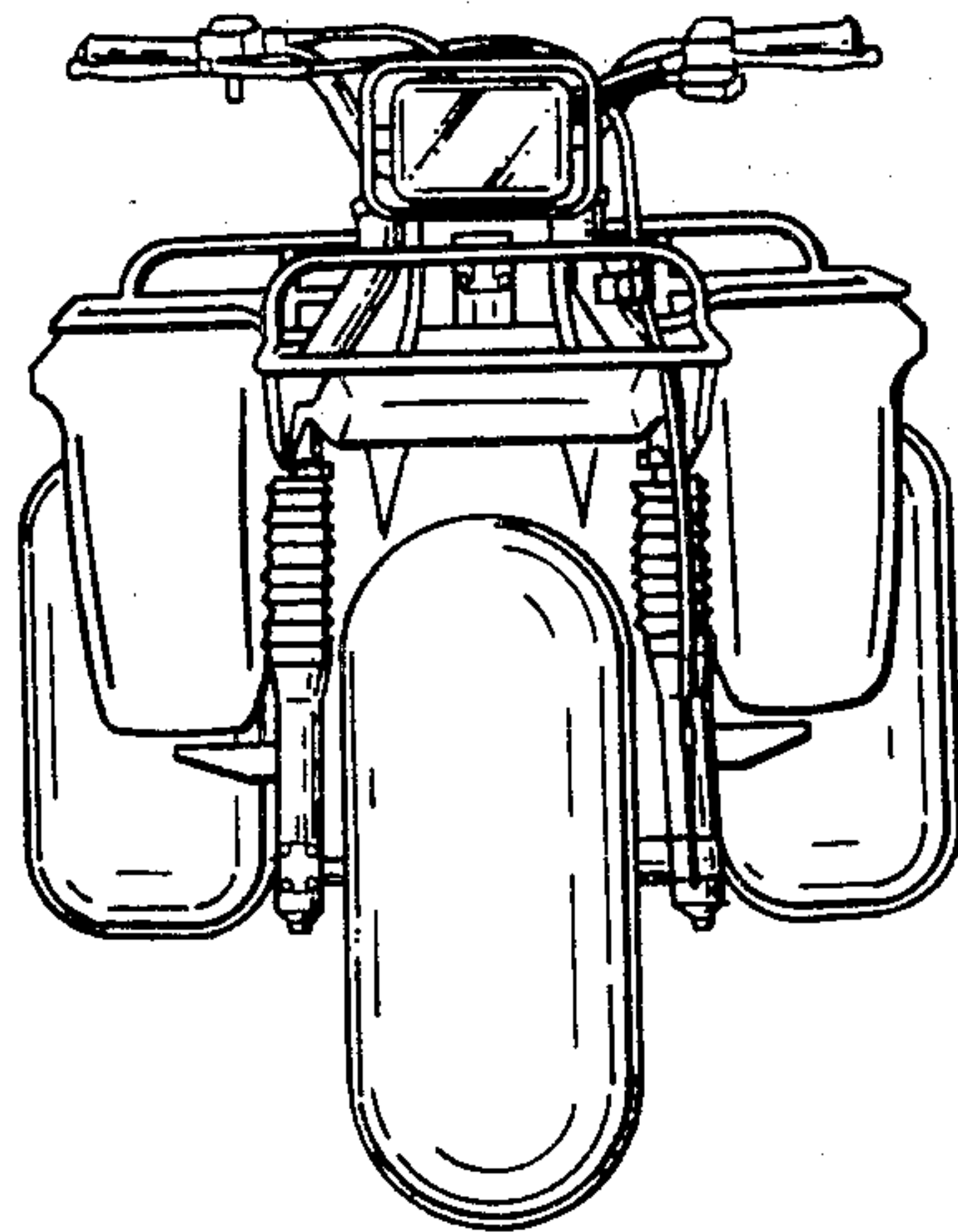
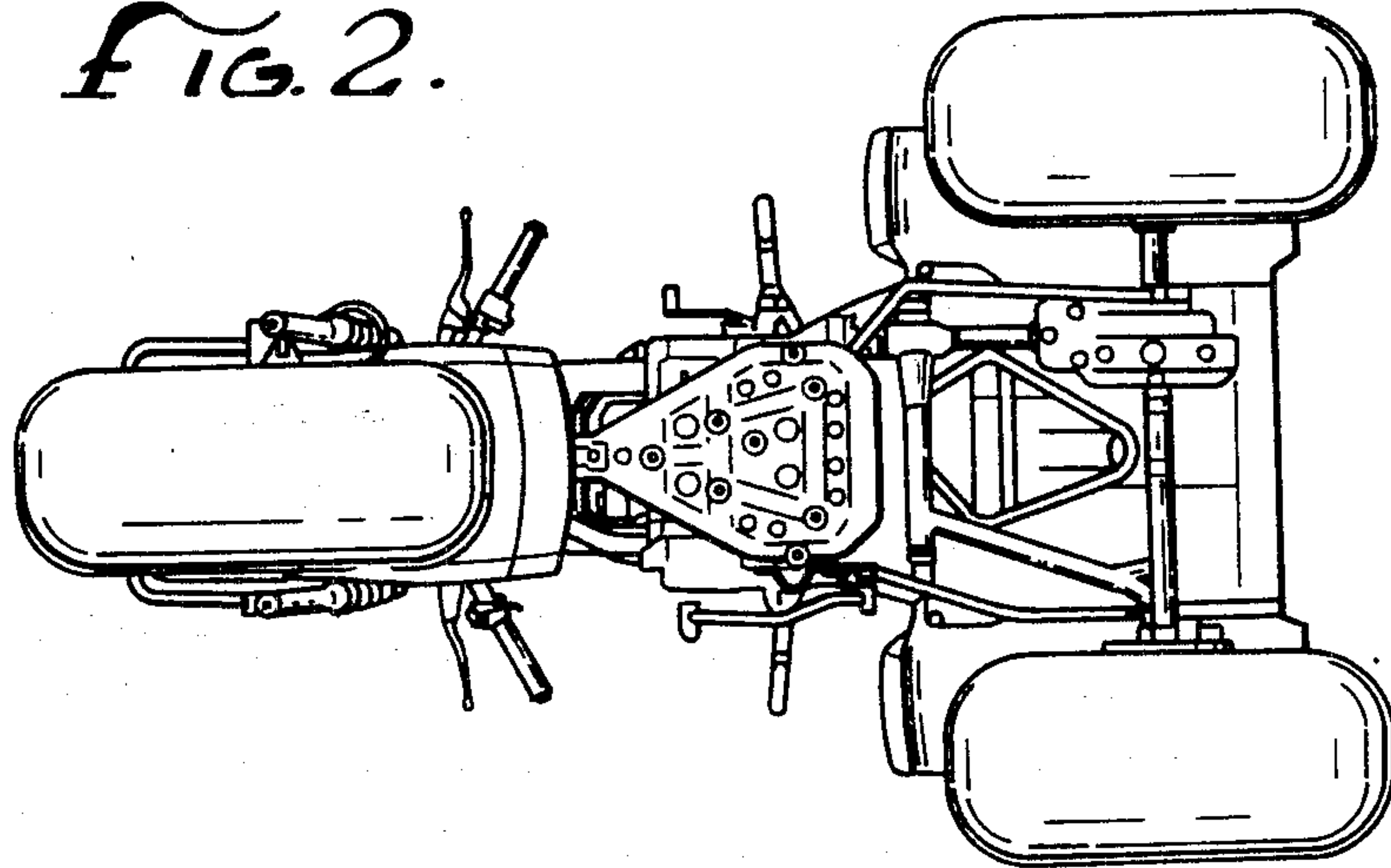

FIG. 3.

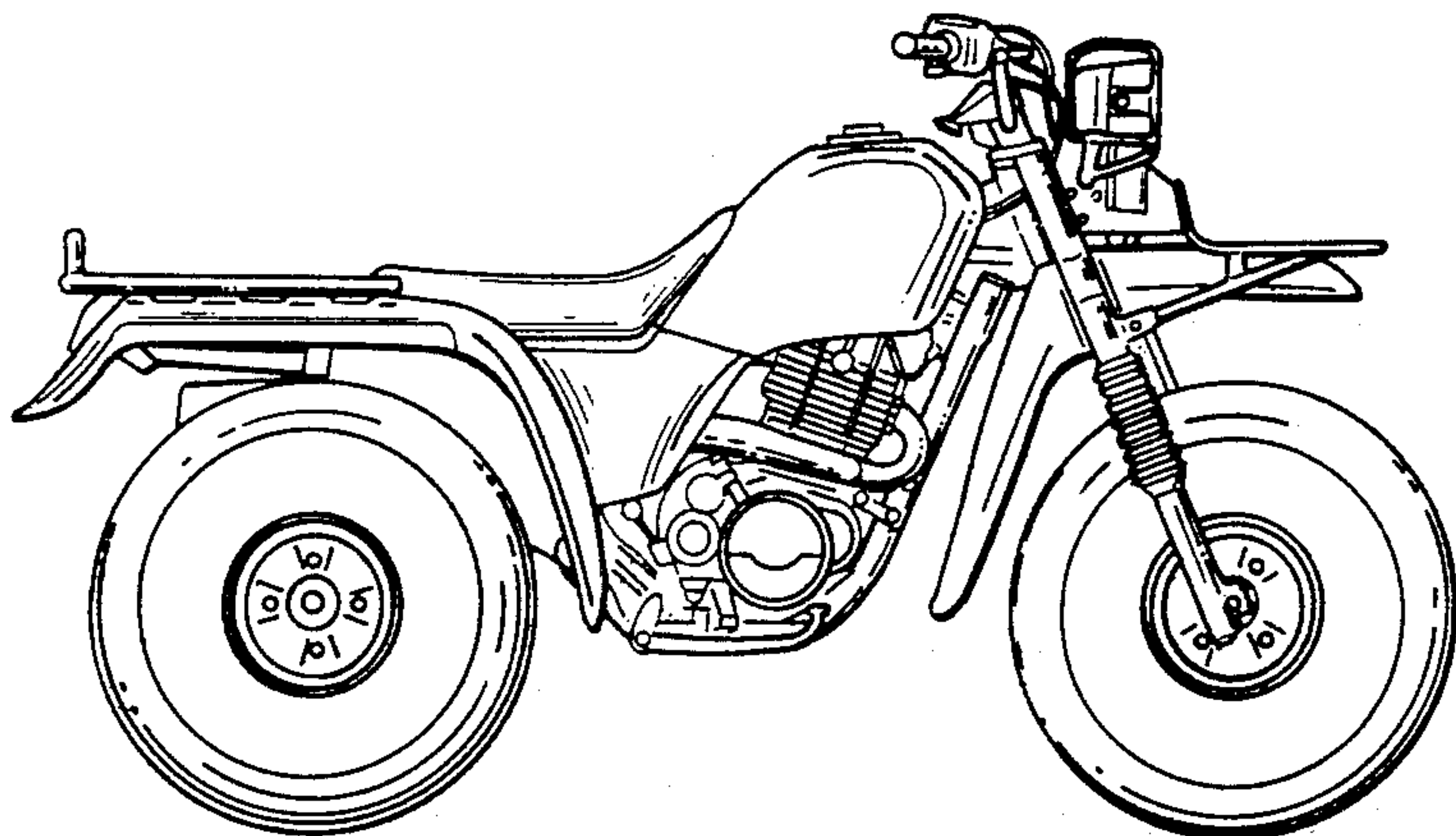

FIG. 4.

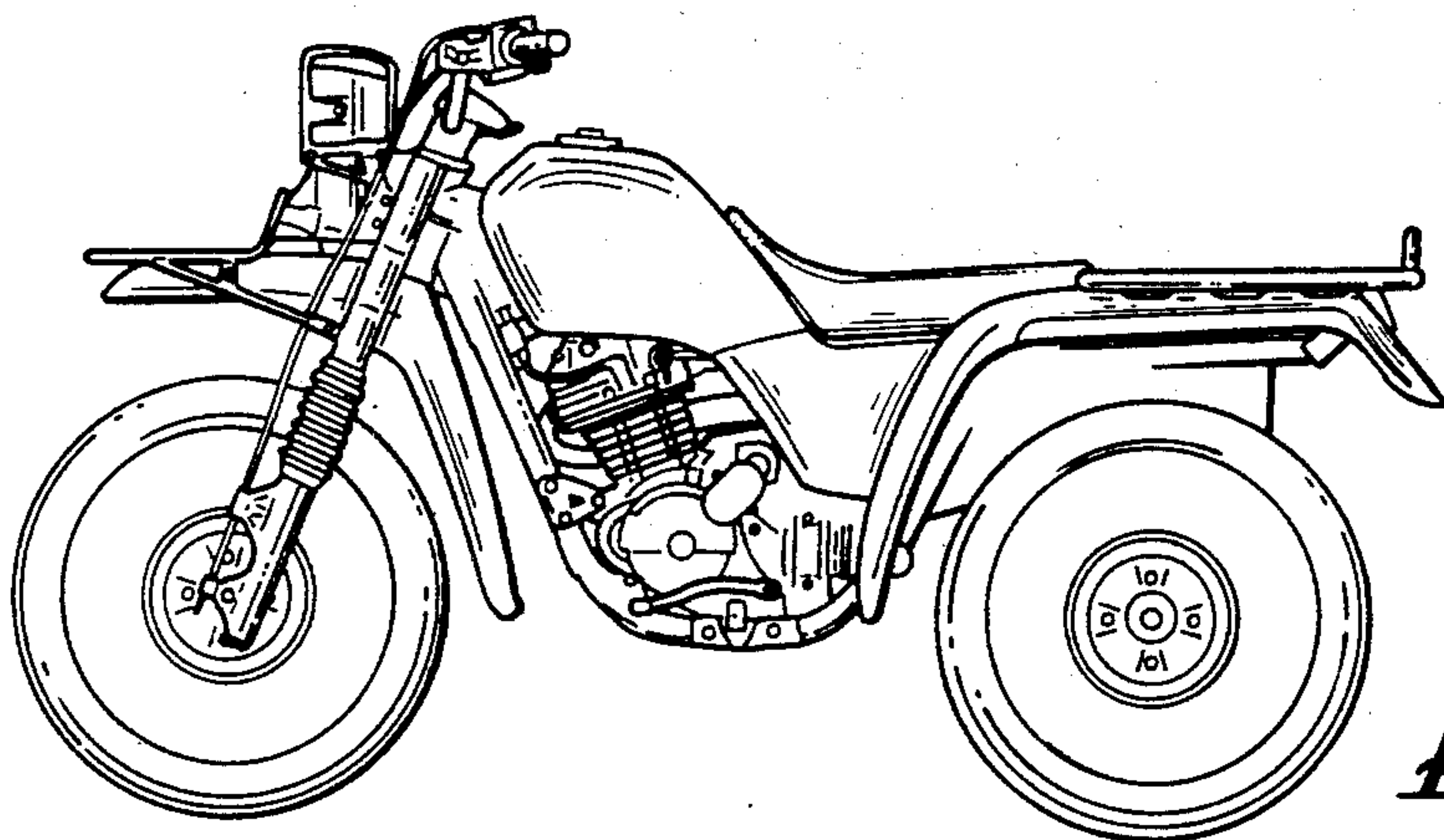

FIG. 5.

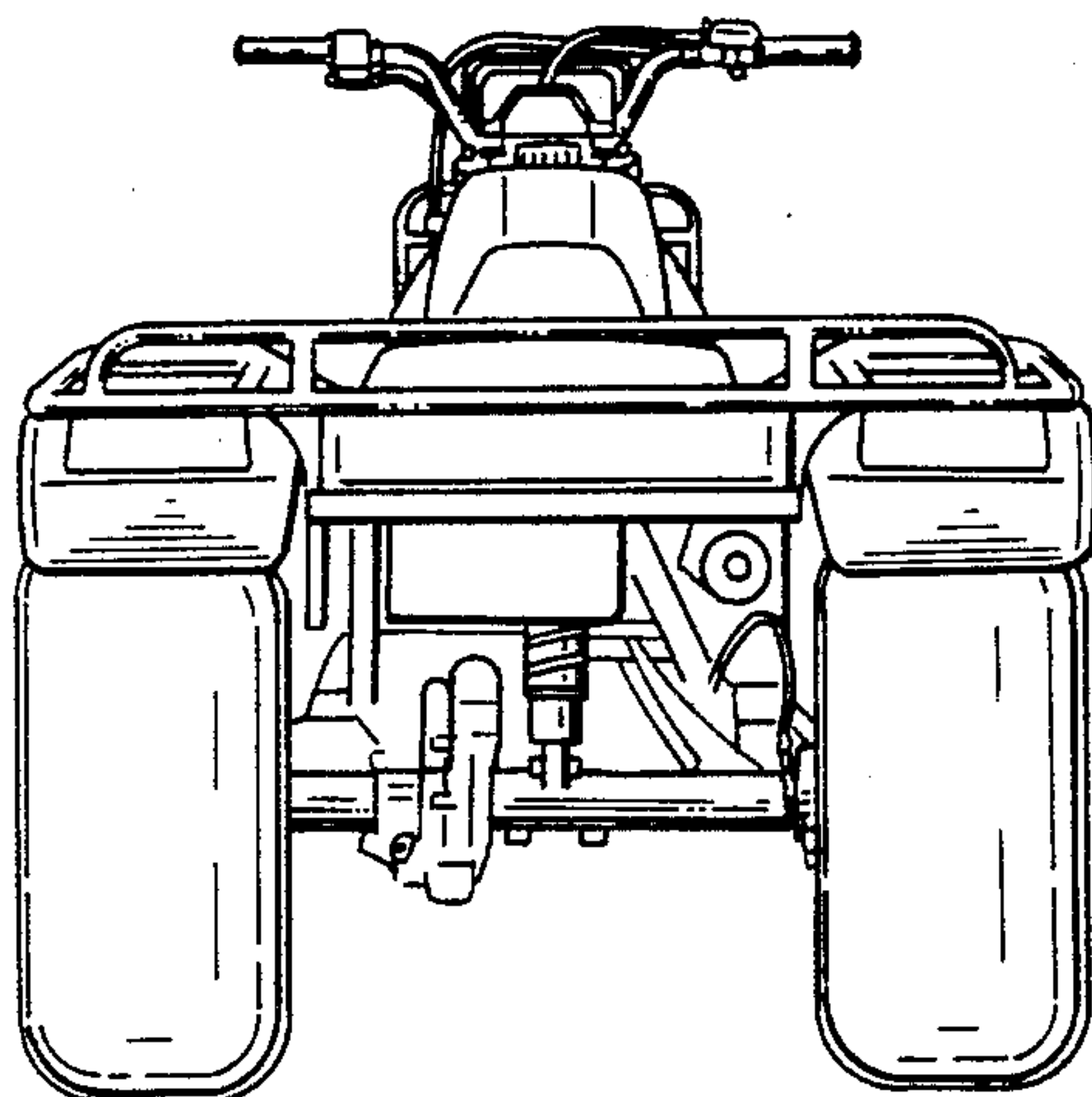

FIG. 6.



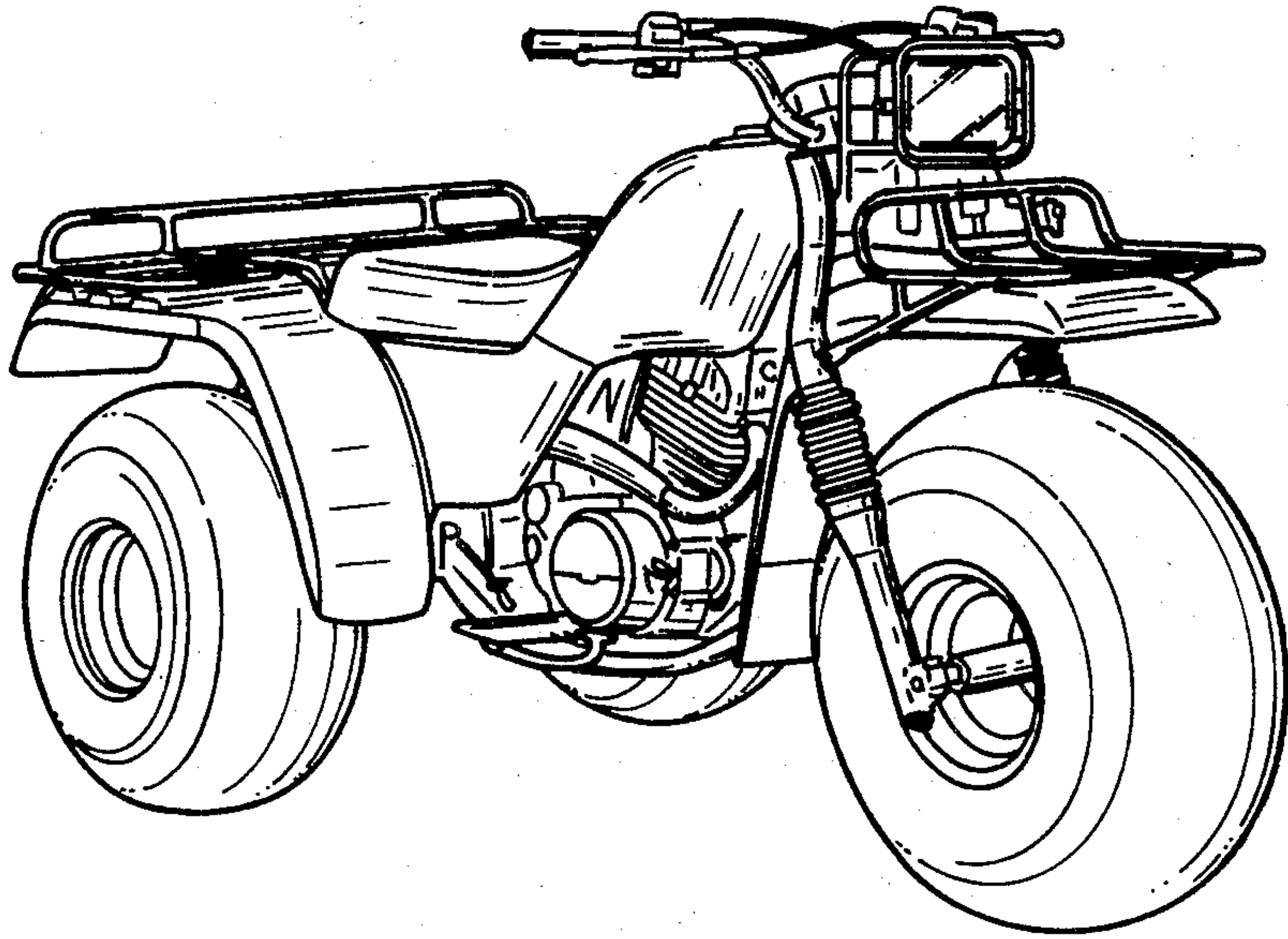

FIG. 7.