

[54] COMBINED REAR WINDOW AND TRUNK LID FOR AN AUTOMOBILE

[75] Inventors: Björn E. A. Envall, Vänersborg, Sweden; Giorgetto Giugiaro, Turin, Italy

[73] Assignee: Saab-Scania Aktiebolag, Trollhattan, Sweden

[**] Term: 14 Years

[21] Appl. No.: 603,944

[22] Filed: Apr. 24, 1984

[30] Foreign Application Priority Data

Oct. 26, 1983 [SE] Sweden 832778
[52] U.S. Cl. D12/183; D12/196
[58] Field of Search D12/196, 183; 296/195, 296/197, 185

[56] References Cited

U.S. PATENT DOCUMENTS

D. 271,681 12/1983 Hughet et al. D12/196

OTHER PUBLICATIONS

Motor Trend, 10/81, p. 68, Rear Window & Trunk Lid of Nissan Stanza, top of page.

Primary Examiner—James M. Gandy
Attorney, Agent, or Firm—Young & Thompson

[57] CLAIM

The ornamental design for a combined rear window and trunk lid for an automobile, as shown.

DESCRIPTION

FIG. 1 is a front and right side perspective view of the outside of a combined rear window and trunk lid for an automobile, showing my new design;
FIG. 2 is a rear perspective view of the inside thereof; and
FIG. 3 is a left side perspective view thereof.

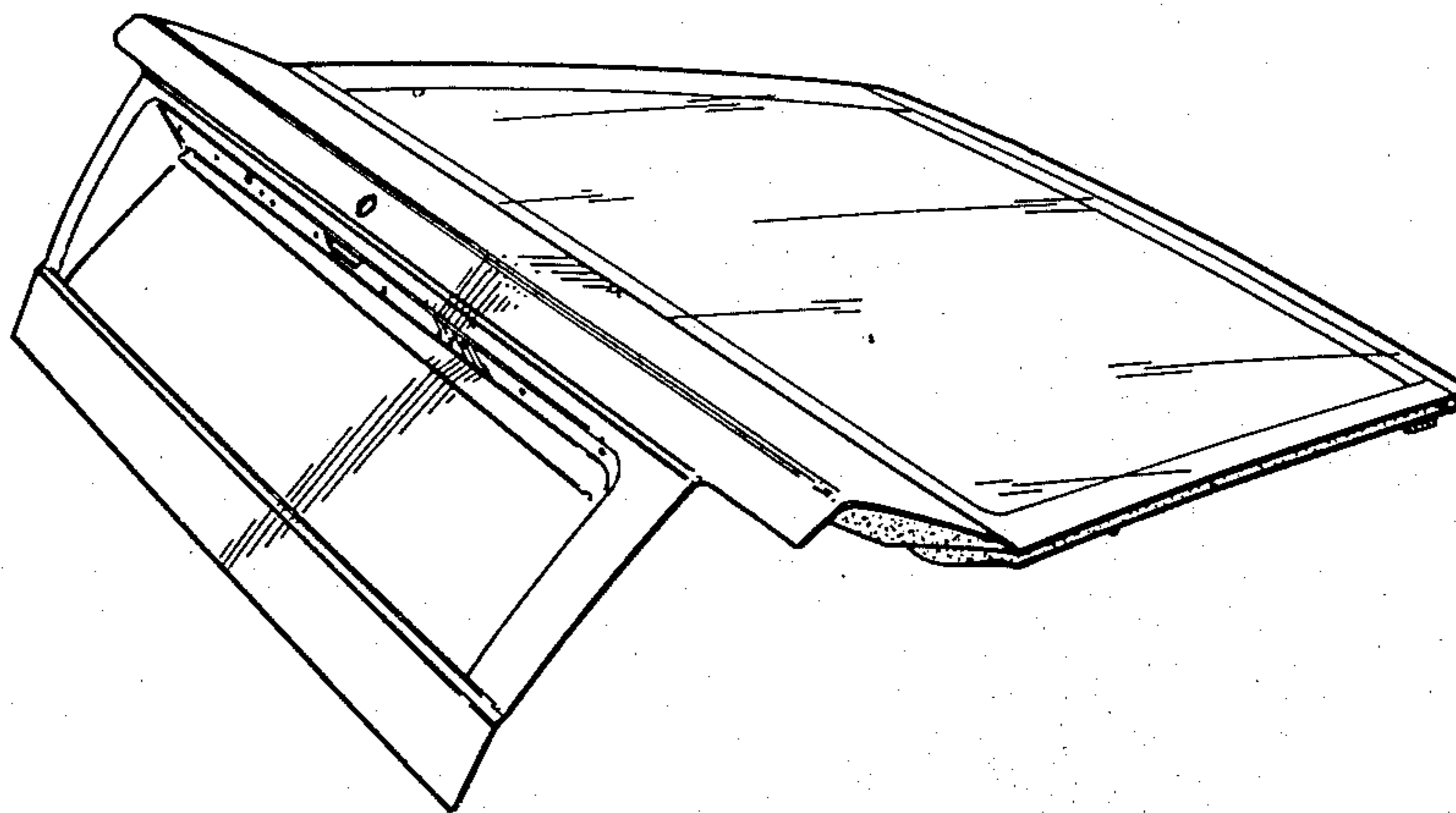

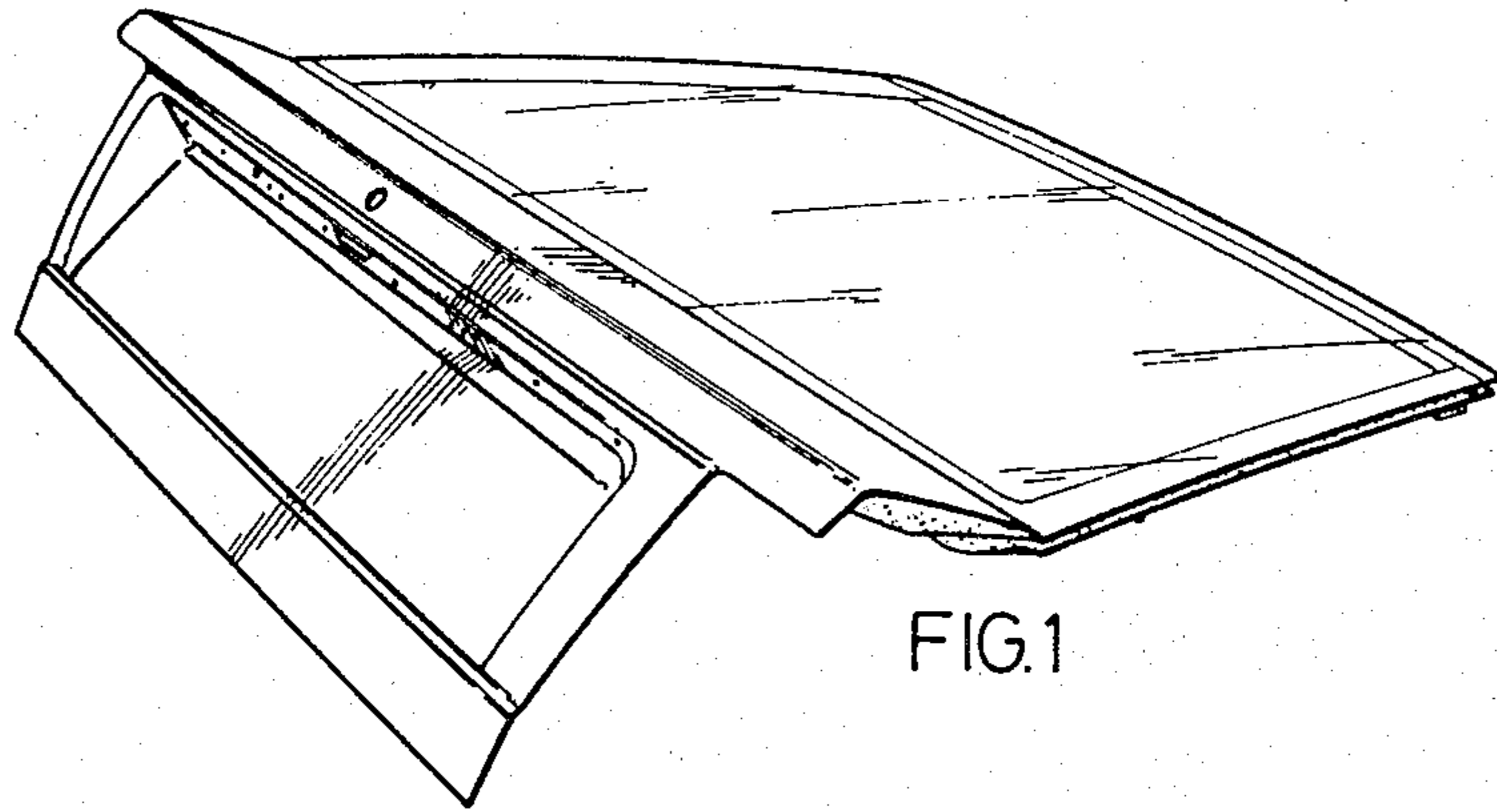

FIG.1

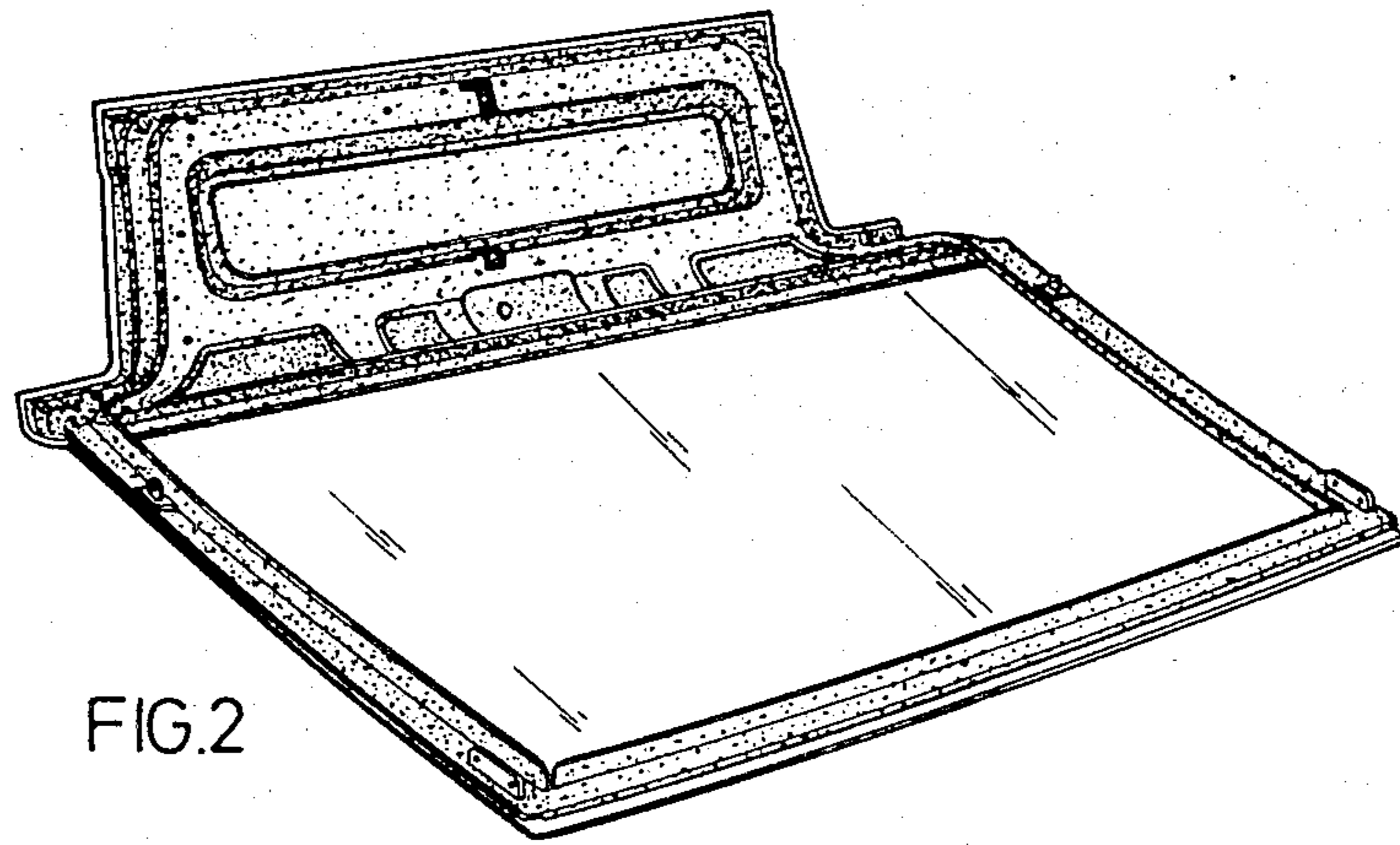

FIG.2

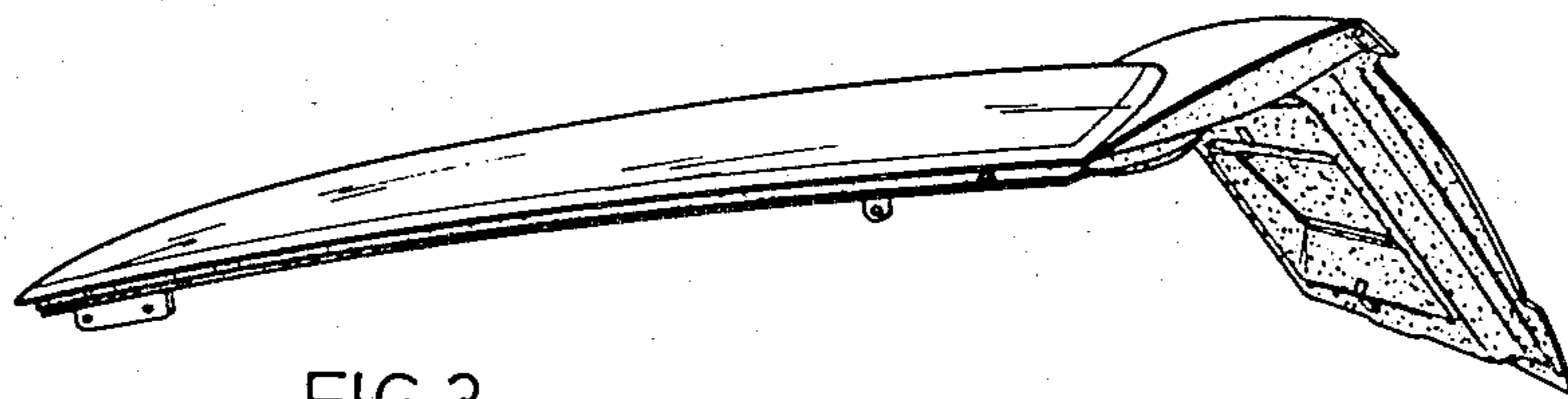

FIG.3