

[54] **VAN TOP**

[75] Inventors: **William P. Johnson**, Syracuse;  
**Charles B. Bonifield**, Warsaw, both  
of Ind.

[73] Assignee: **Coachmen Industries, Inc.**, Elkhart,  
Ind.

[\*\*] Term: **14 Years**

[21] Appl. No.: **595,607**

[22] Filed: **Apr. 2, 1984**

[52] U.S. Cl. .... **D12/156**

[58] Field of Search ..... **D12/156; 296/26, 99 R,**  
**296/100, 210**

[56] **References Cited**

**U.S. PATENT DOCUMENTS**

D. 250,331 11/1978 Snyder ..... **D12/156**

**OTHER PUBLICATIONS**

R. V. Business, 10/82, p. 45, Top of Skyview Van,  
lower right side of page.

*Primary Examiner*—James M. Gandy  
*Attorney, Agent, or Firm*—Thomas J. Dodd

[57] **CLAIM**

The ornamental design for a van top, as shown and  
described.

**DESCRIPTION**

FIG. 1 is a perspective view of my new van top from  
the front and right side;

FIG. 2 is a left side elevational view thereof, the right  
side being a mirror image;

FIG. 3 is a rear elevational view thereof; and

FIG. 4 is a front elevational view thereof.

The broken line drawing of the van is for the illustrative  
purposes only and forms no part of the claimed design.

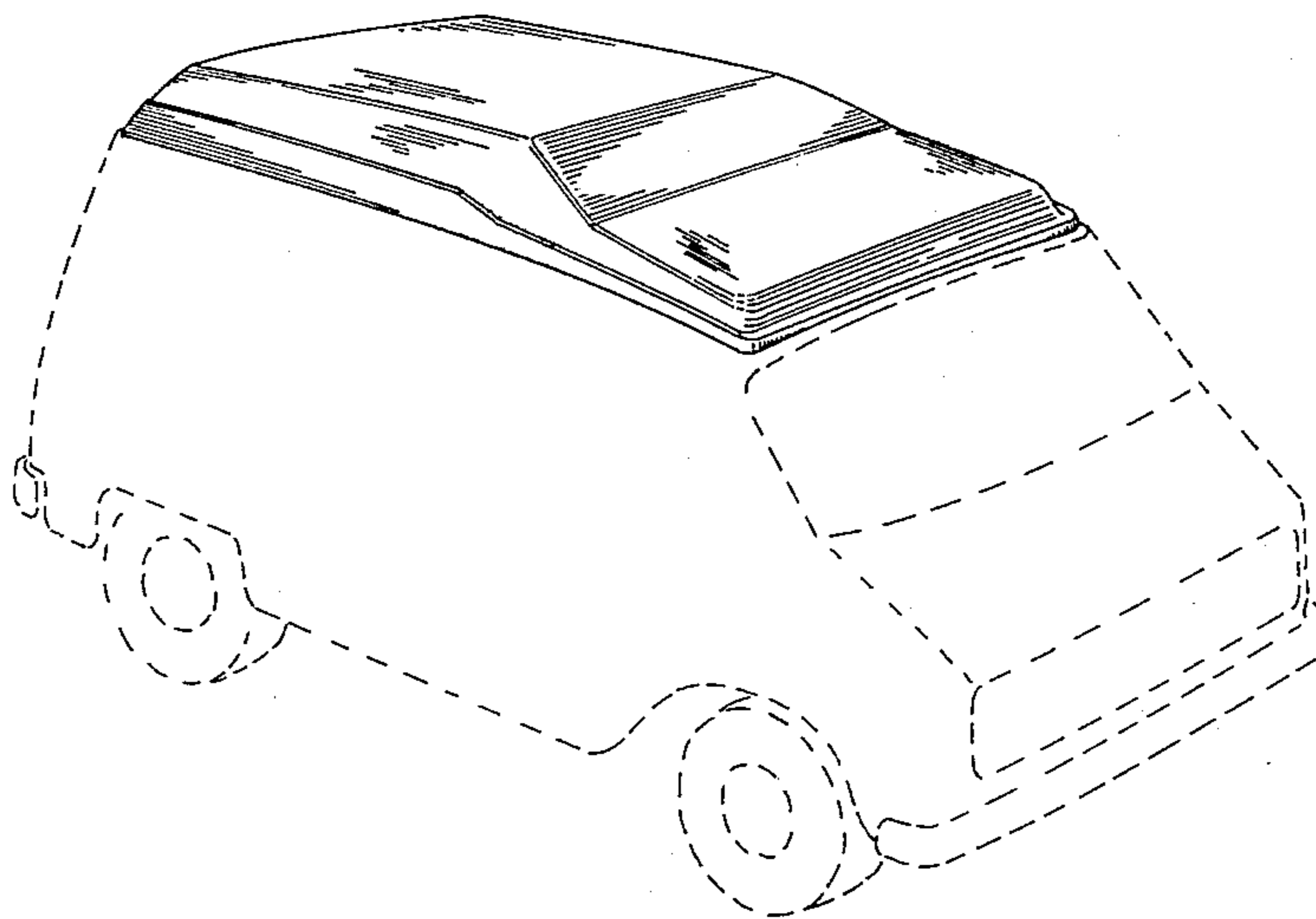

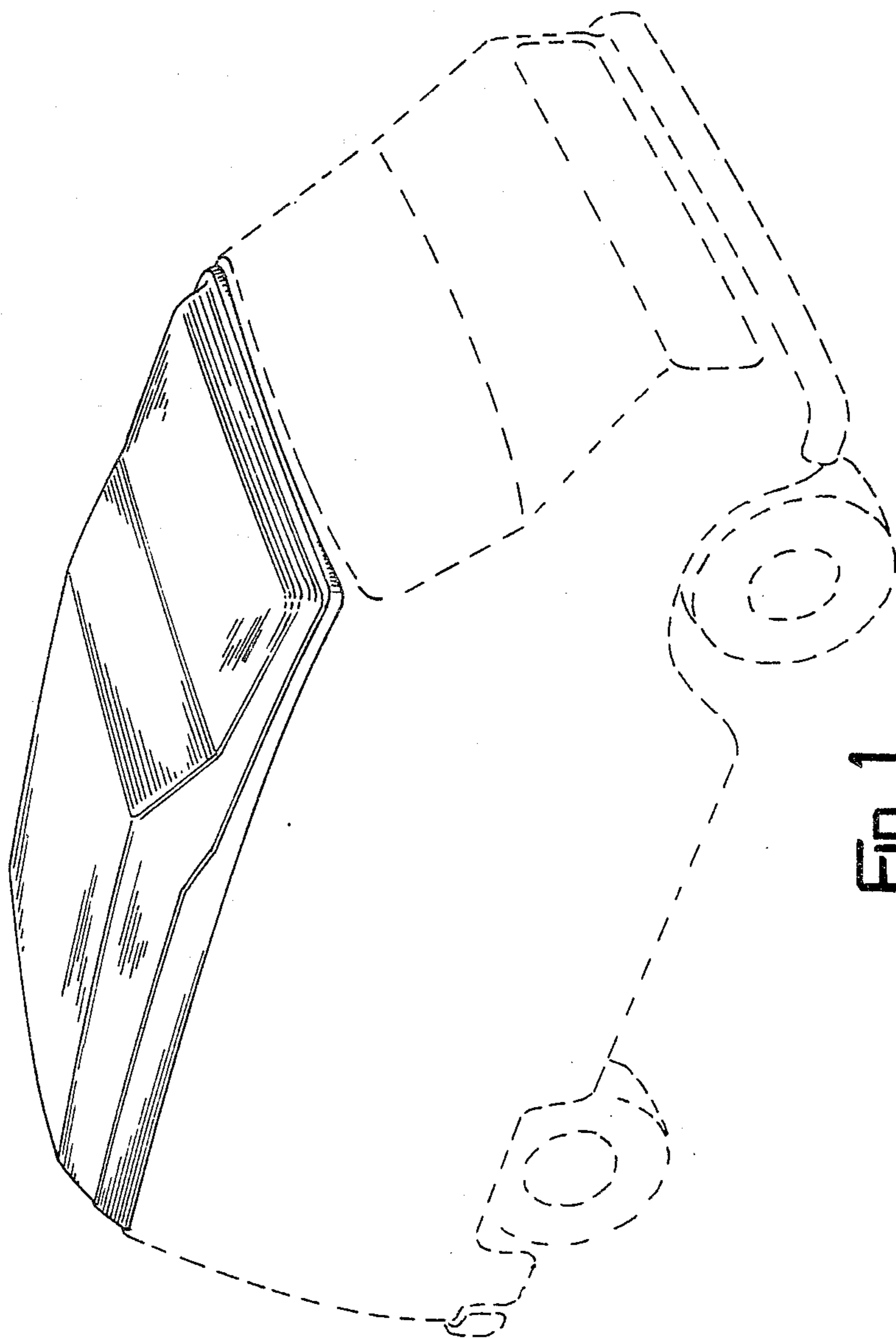

FIG. 1

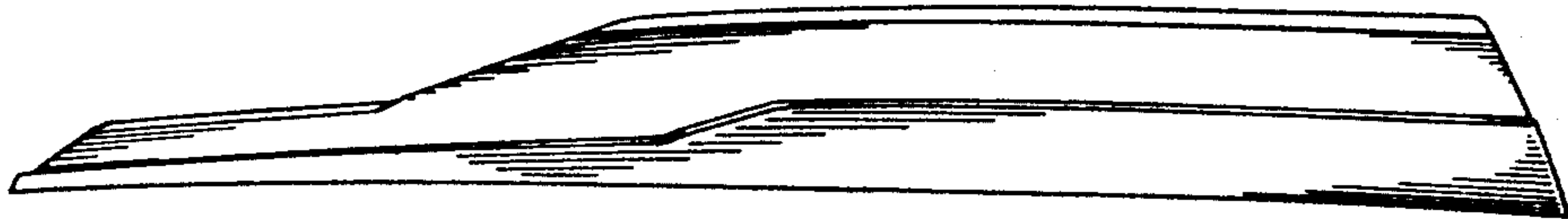

Fig. 2

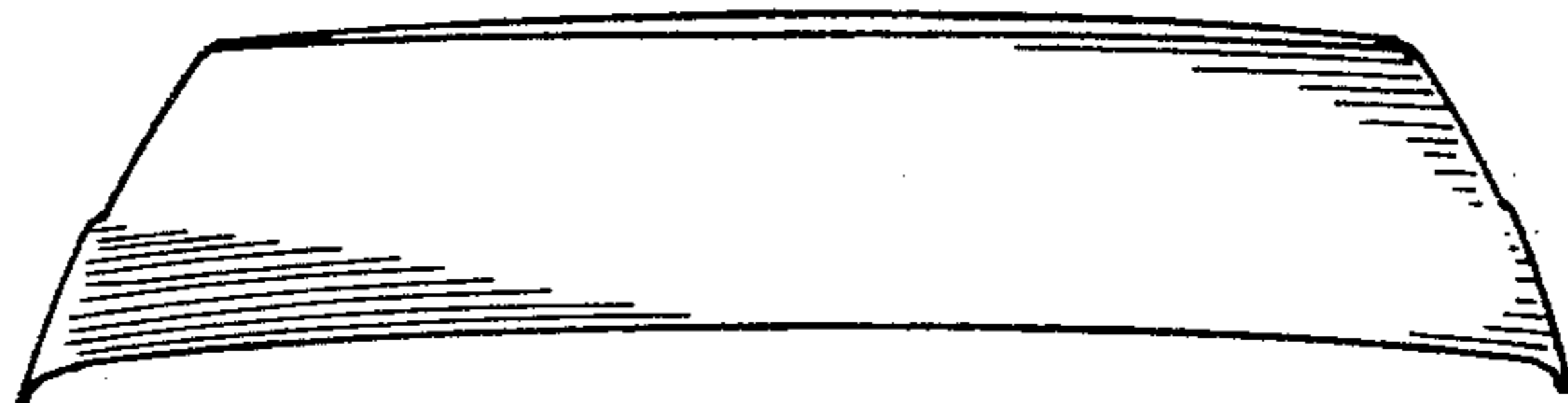

Fig. 3

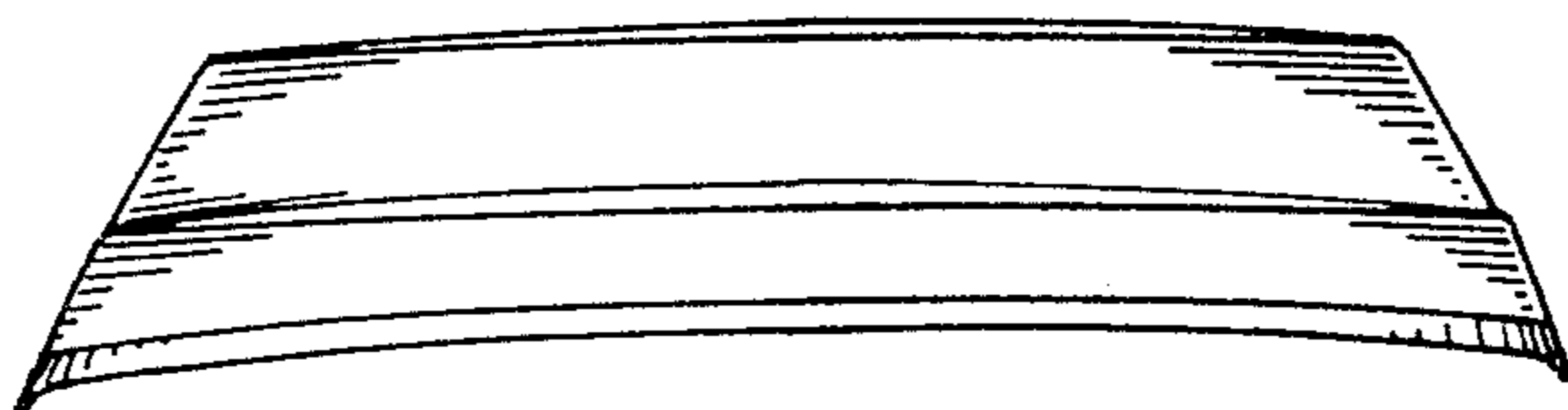

Fig. 4