

[54] OUTDOOR ADVERTISING SIGN

[76] Inventor: Peter Wiens, 2225 Pine Street, Prince George, British Columbia, Canada

[**] Term: 14 Years

[21] Appl. No.: 637,117

[22] Filed: Aug. 2, 1984

[30] Foreign Application Priority Data

Feb. 8, 1984 [CA] Canada 08-02-84-7

[52] U.S. Cl. D20/39

[58] Field of Search D20/10, 39, 41; 40/584, 40/605, 606, 607, 624, 559, 560

[56] References Cited

U.S. PATENT DOCUMENTS

4,299,043 11/1981 Lathrop et al. 40/624

OTHER PUBLICATIONS

Signs of the Times—Mar. 1982—p. 78—GRC Sign.

Primary Examiner—Catherine E. Kemper

[57] CLAIM

The ornamental design for a outdoor advertising sign, as shown.

DESCRIPTION

FIG. 1 is a perspective view of a outdoor advertising sign showing my new design;

FIG. 2 is a top plan view thereof;

FIG. 3 is a side elevational view taken from the right of FIG. 1;

FIG. 4 is a side elevational view taken from the left of FIG. 1;

FIG. 5 is a front elevational view thereof;

FIG. 6 is a rear elevational view thereof;

FIG. 7 is a bottom plan view thereof.

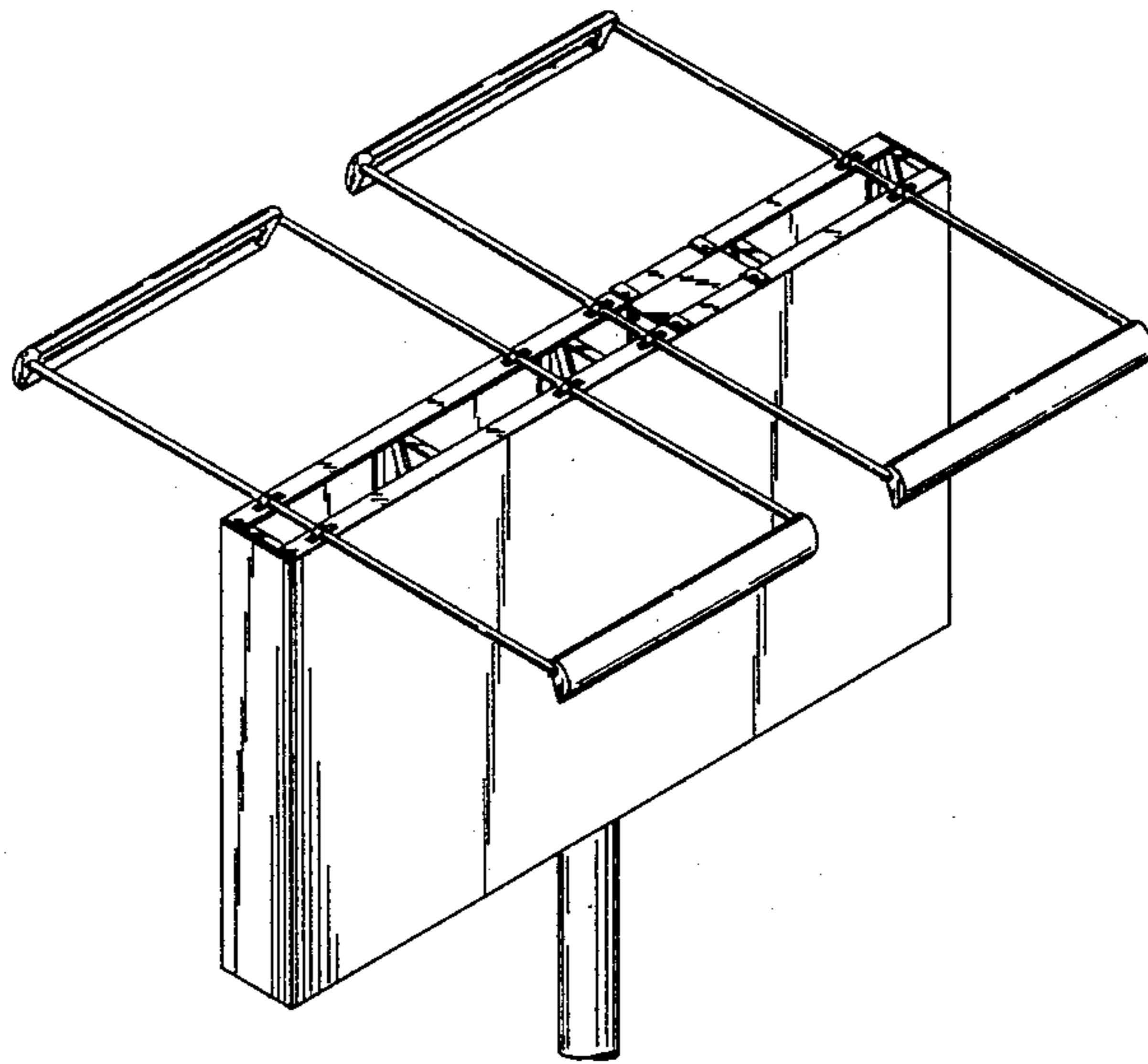

Fig. 1.

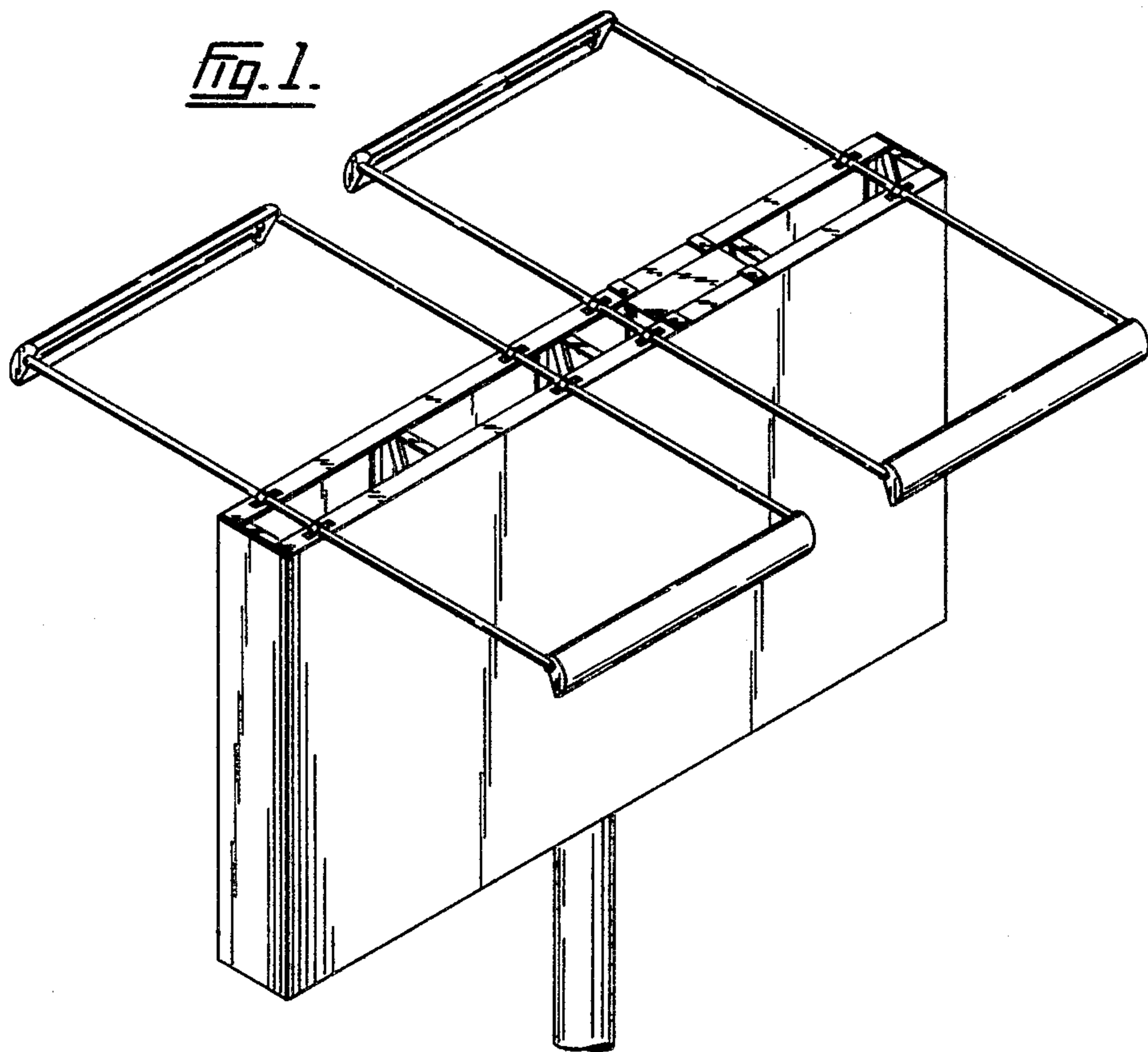
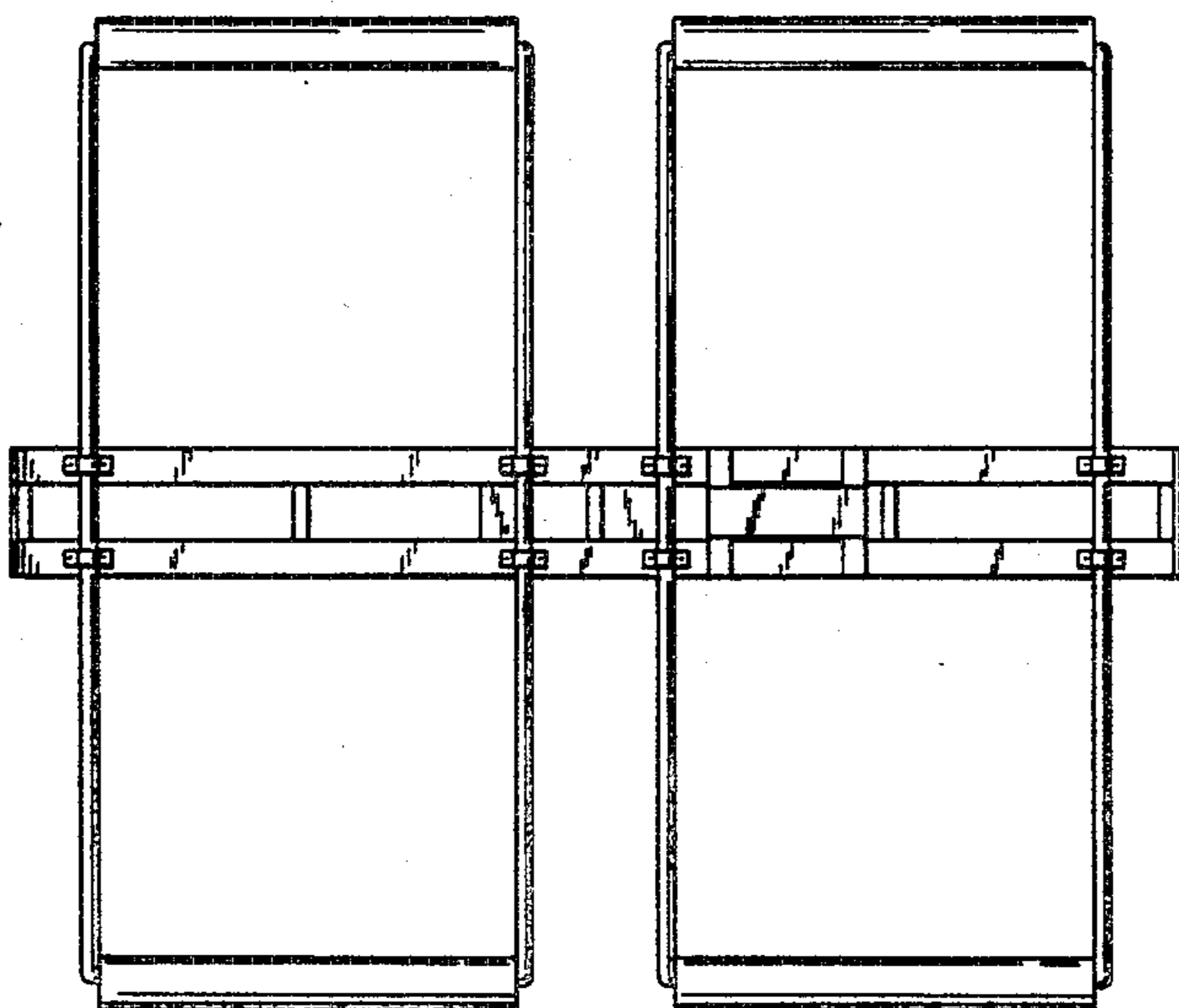

Fig. 2.



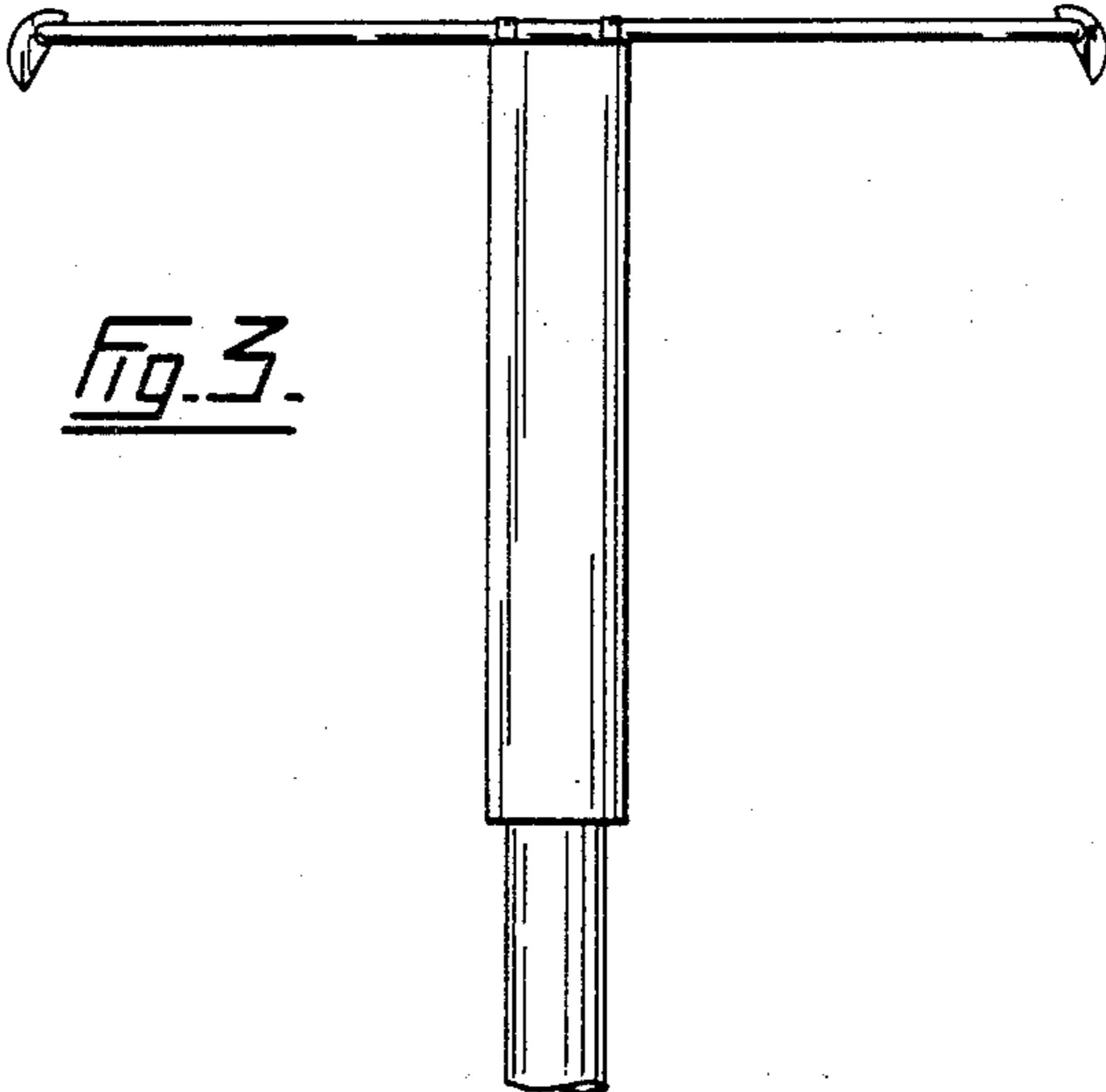

Fig. 3.

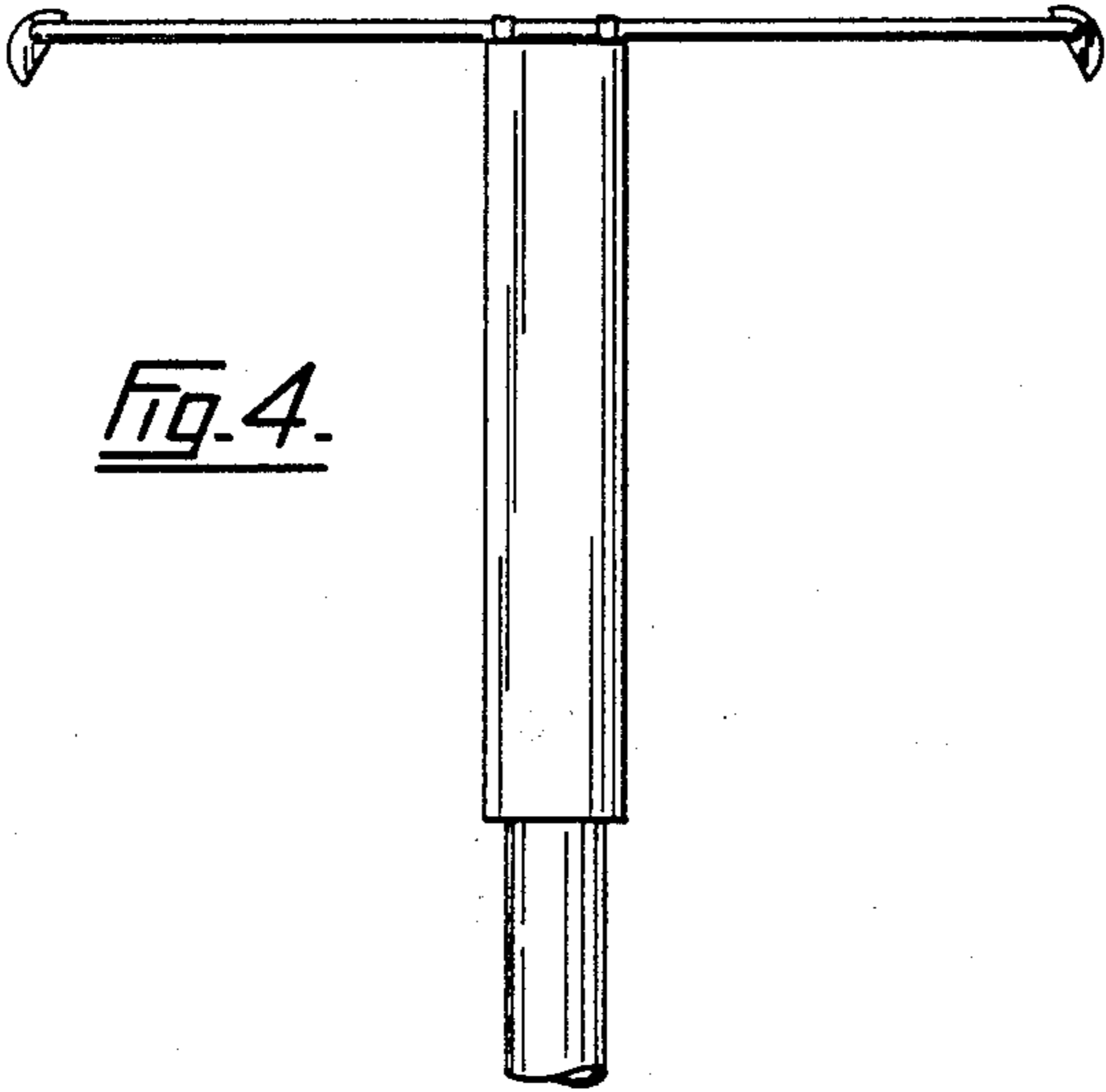

Fig. 4.

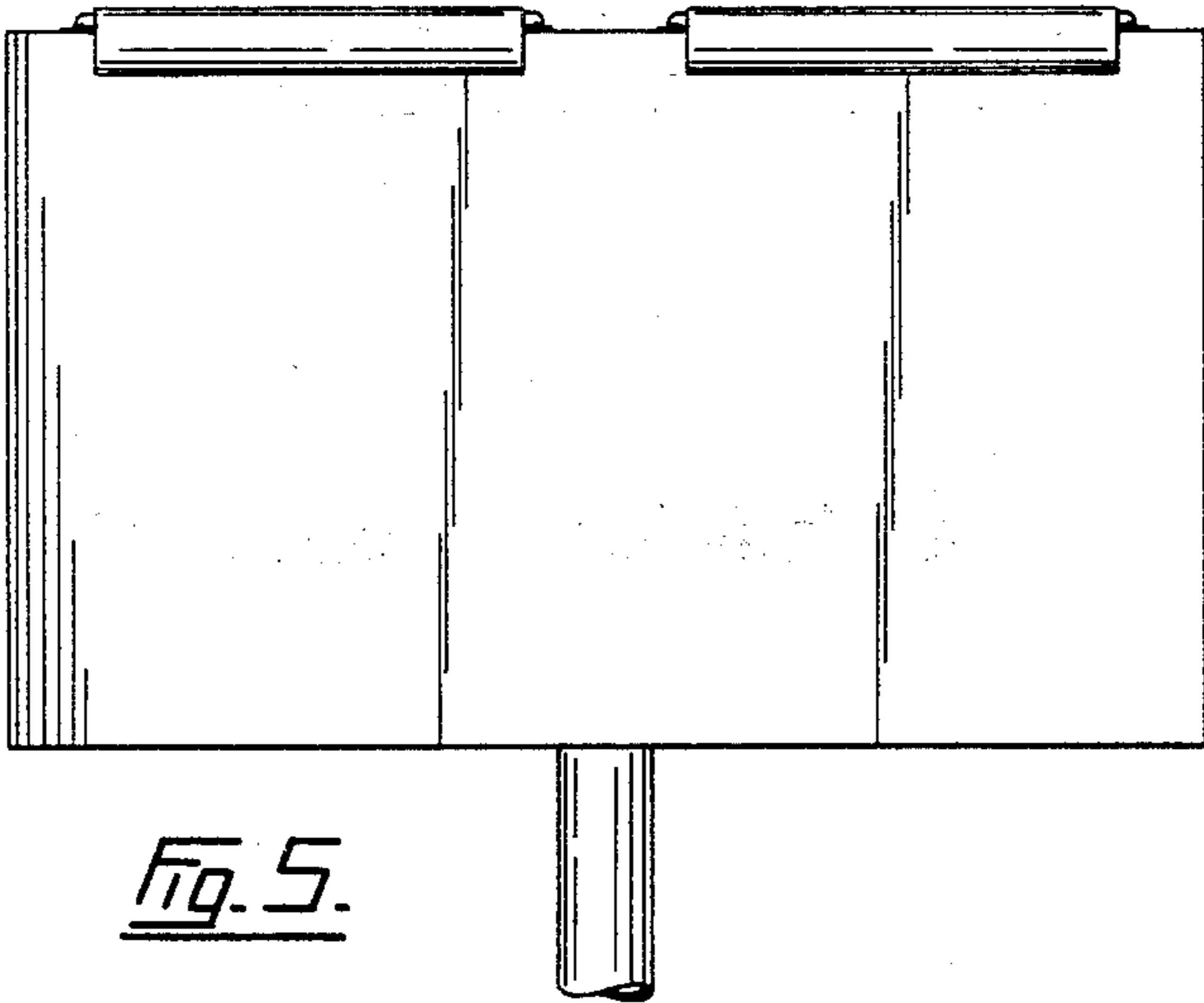

Fig. 5.

Fig. 6.

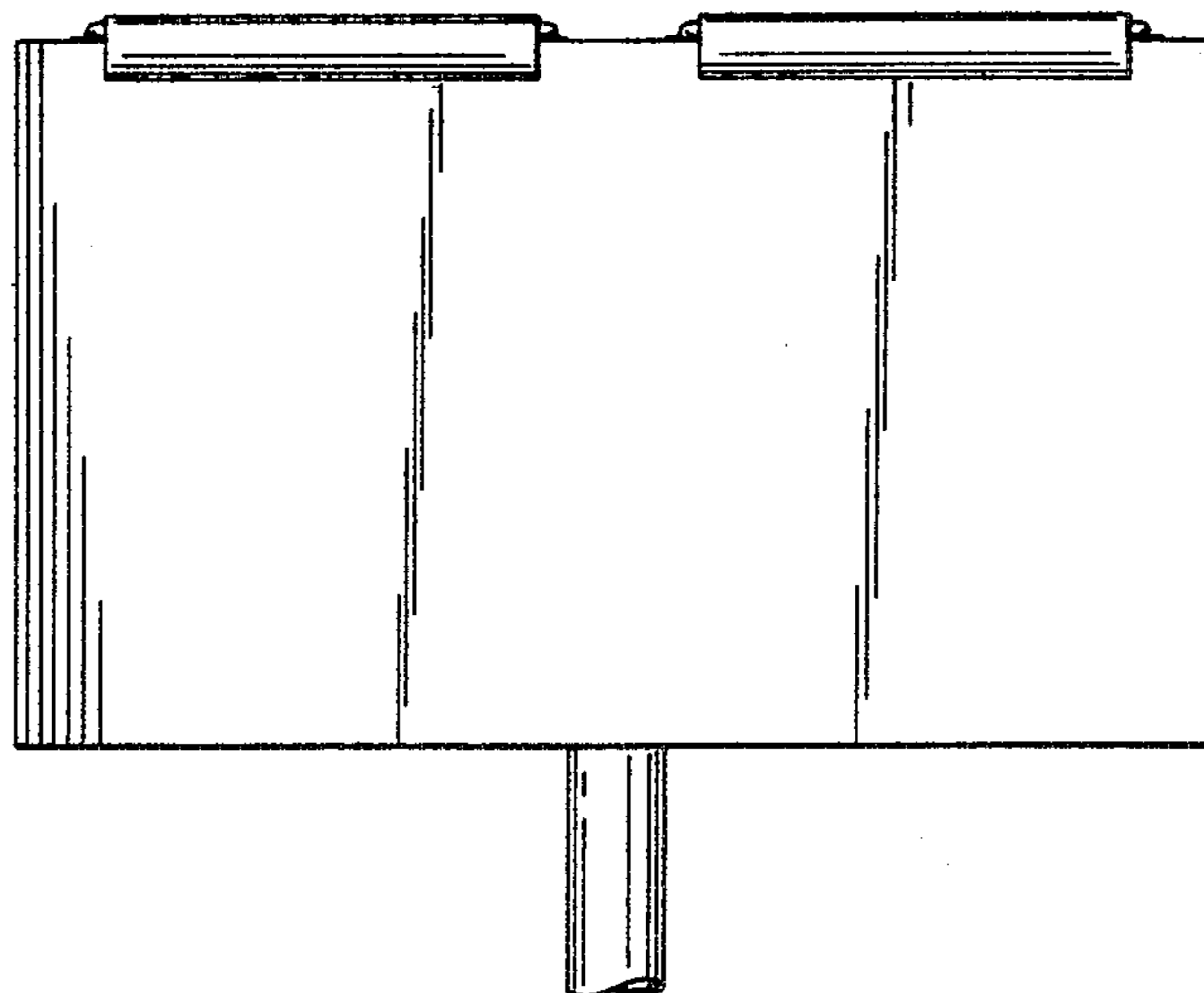

Fig. 7.

