

[54] **AIR COMPRESSOR FOR TUBS AND THE LIKE**

4,406,594 9/1983 Smaby et al. 417/902

[75] **Inventor: James E. Kingston, Arlington, Wash.**

[73] **Assignee: Hollibaugh Manufacturing Company, Inc., Marysville, Wash.**

[**] **Term: 14 Years**

[21] **Appl. No.: 470,818**

[22] **Filed: Feb. 28, 1983**

[52] **U.S. Cl. D15/9**

[58] **Field of Search D15/9; 417/902**

[56] **References Cited**

U.S. PATENT DOCUMENTS

| | | | |
|-----------|--------|---------|---------|
| 3,389,853 | 6/1968 | Dirk | 417/902 |
| 3,902,629 | 9/1975 | Kushner | 417/902 |
| 4,277,955 | 7/1981 | Parker | 417/902 |

OTHER PUBLICATIONS

Motor Boating—Jan. 1961, p. 322, Lantern at top of page.

Primary Examiner—Catherine E. Kemper
Attorney, Agent, or Firm—Seed and Berry

[57] **CLAIM**

The ornamental design for an air compressor for tubs and the like, substantially as shown and described.

DESCRIPTION

FIG. 1 is a top perspective view of an air compressor for tubs and the like showing my new design; FIG. 2 is a top plan view thereof; FIG. 3 is a bottom plan view thereof; FIG. 4 is a side elevation view thereof; FIG. 5 is a front elevation view thereof; and FIG. 6 is a rear elevation view thereof.

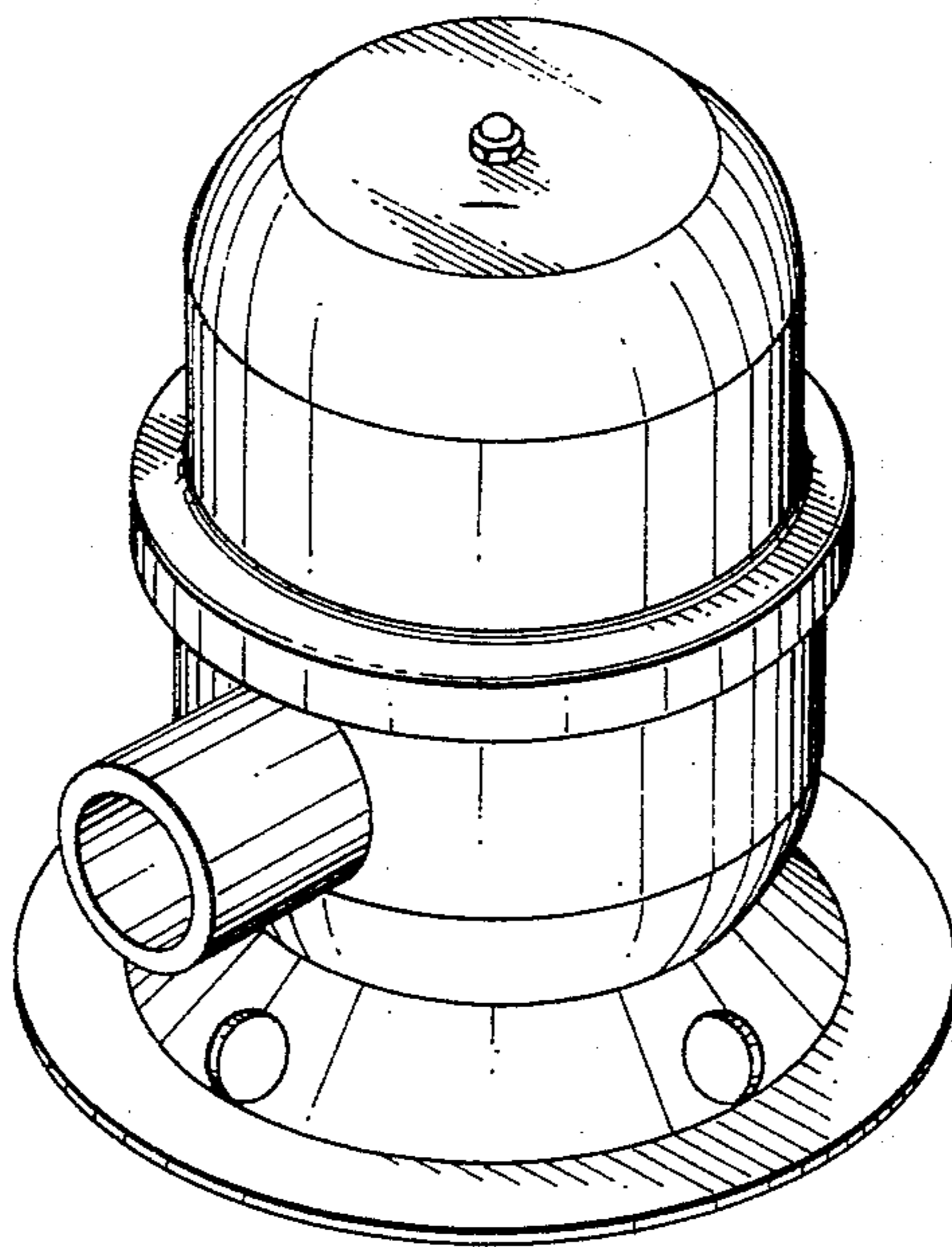

Fig. 1

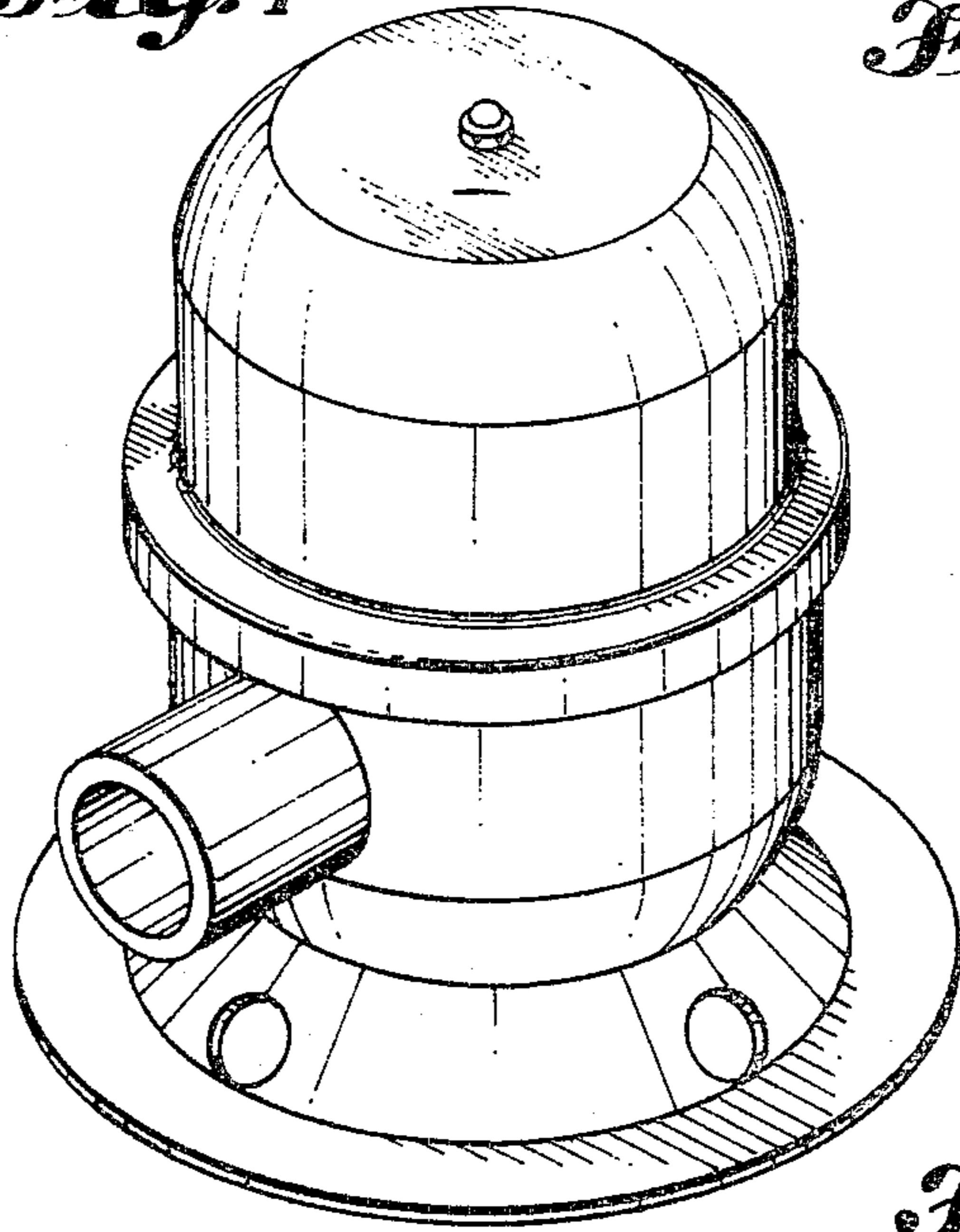

Fig. 4

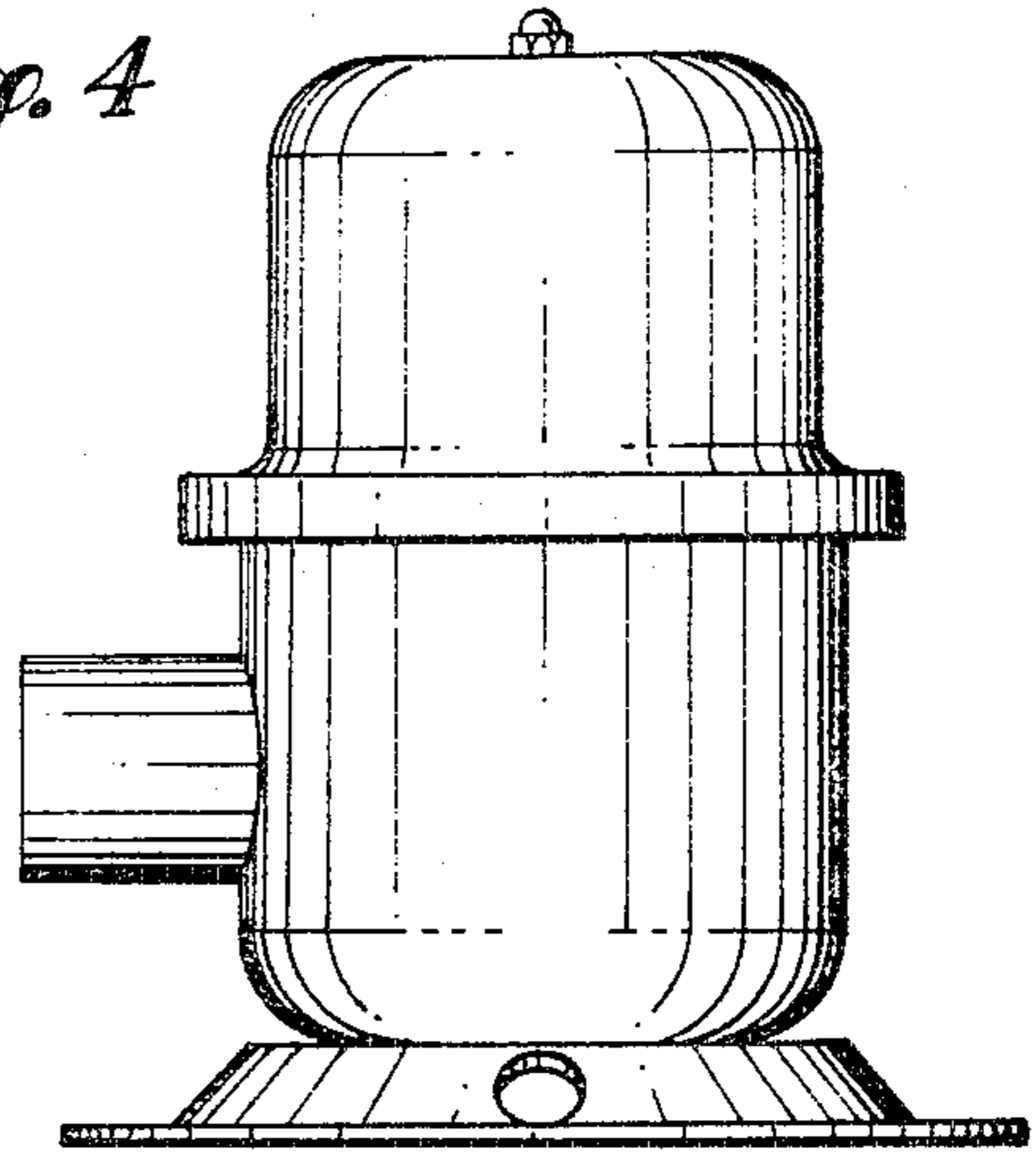

Fig. 5

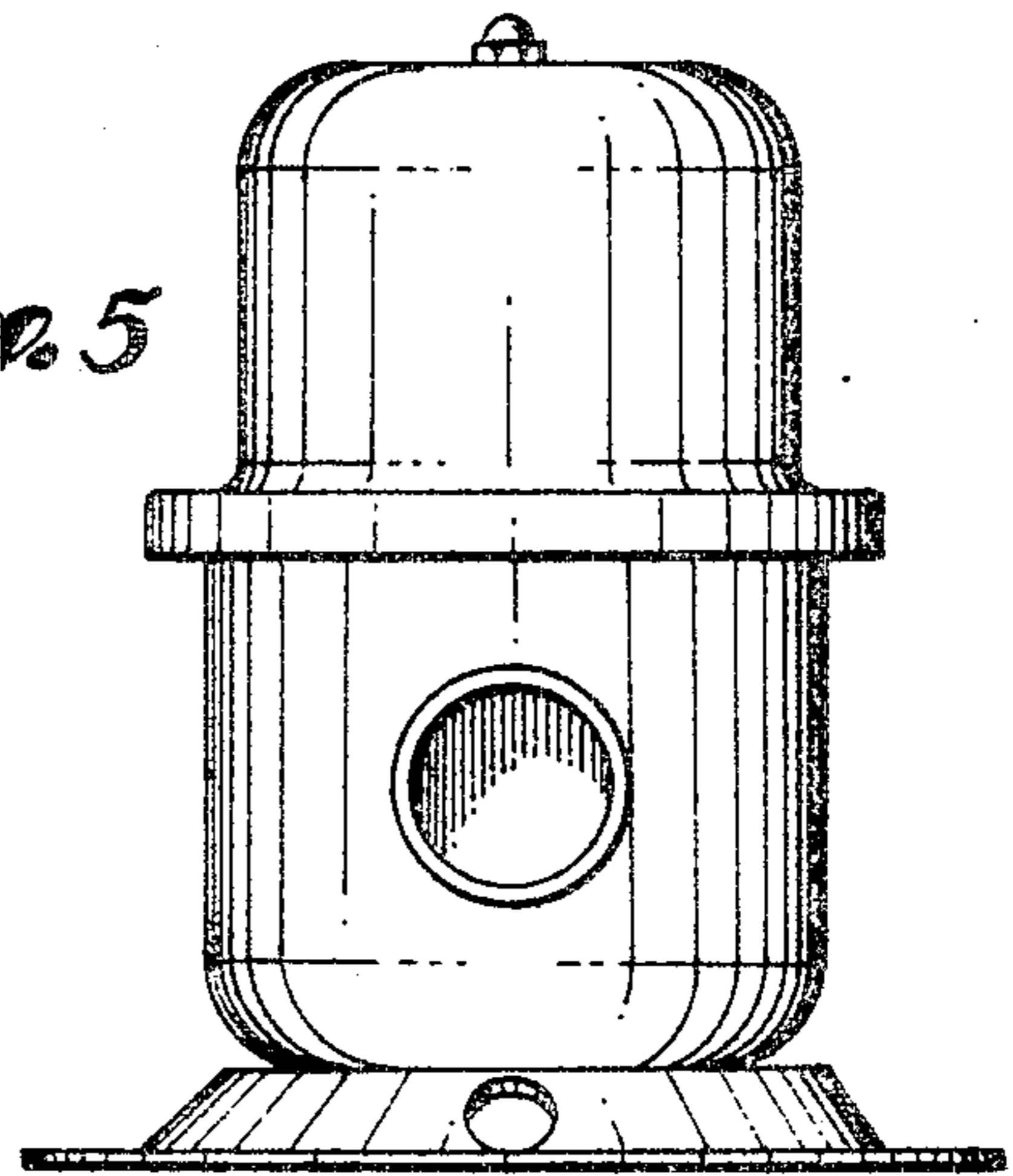

Fig. 2

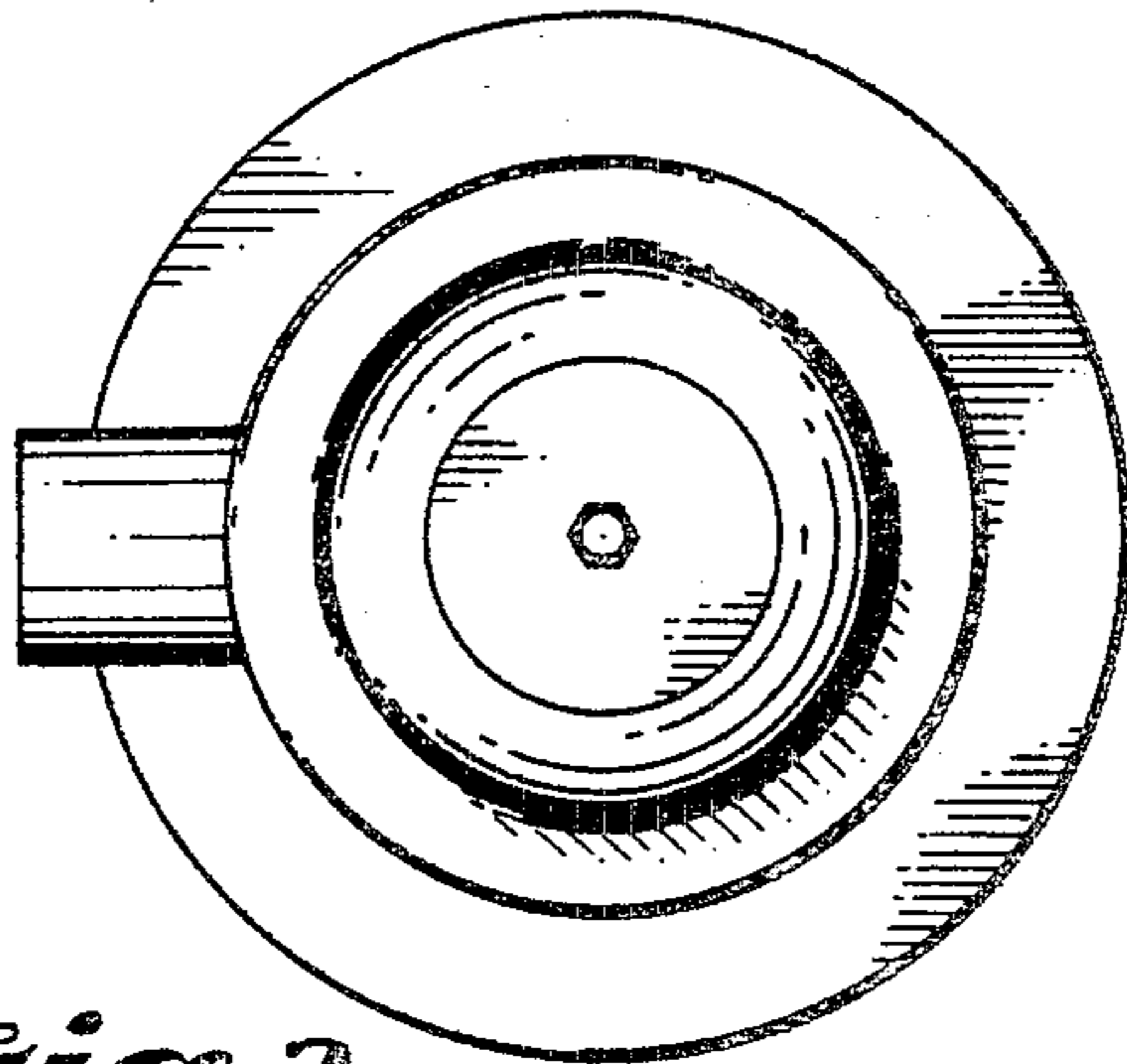

Fig. 6

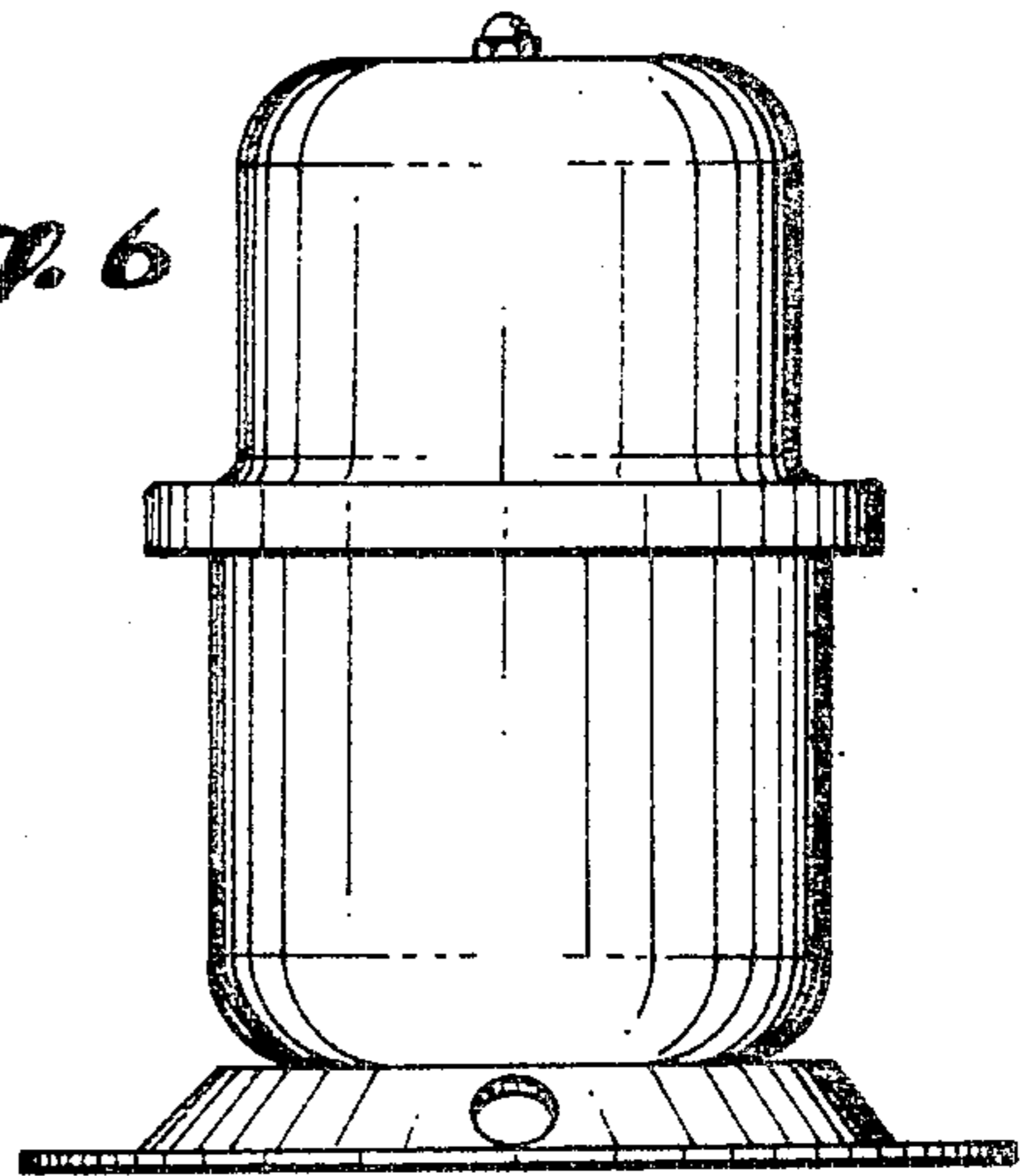

Fig. 3

