

[54] MULTICOMPARTMENT COMPACT

[75] Inventors: Ugo Campello; Enrico Racca, both of Miami, Fla.; Pierluigi Sosta; Deris Baggiolini, both of Concesio, Italy

[73] Assignee: New High Glass, Miami, Fla.

[**] Term: 14 Years

[21] Appl. No.: 671,472

[22] Filed: Nov. 14, 1984

[52] U.S. Cl. D28/83; D9/420

[58] Field of Search D28/38, 73, 76-79, D28/82-86; D3/39; D9/420, 423, 424; 206/235, 385, 581, 823; 362/135-137; 220/DIG. 26; 132/1 R, 79 R, 79 S, 79 F, 79 G, 82 R, 82 A, 82 C-82 S, 83 R, 83 C, 83 G, 83 F

[56] References Cited

U.S. PATENT DOCUMENTS

D. 105,029	6/1937	Olson	D9/420
D. 258,391	2/1981	Bohn	D28/78 X
1,625,455	4/1927	Corry	132/83 R
2,010,521	8/1935	Kreisler	220/20
2,258,543	10/1941	Cressaty	D28/78 X
2,373,852	4/1945	Rappaport	D28/78 X
2,465,946	2/1919	Velez	132/83 R
2,534,100	12/1950	Baumgartner	206/235
3,637,278	1/1972	Easterbrooks	132/83 R

3,918,920	11/1975	Barber	206/306
3,941,237	3/1976	MacGregor, Jr.	206/306

FOREIGN PATENT DOCUMENTS

0116479	8/1984	European Pat. Off.	362/136
668617	11/1929	France	206/235
802303	9/1936	France	132/82 C
943224	3/1949	France	132/79 C
987042	8/1951	France	206/235
2470555	6/1981	France	206/823
426283	4/1935	United Kingdom	206/1.8

Primary Examiner—Louis S. Zarfes
Attorney, Agent, or Firm—Anthony J. Casella; Gerald E. Hespos

[57] CLAIM

The ornamental design for a multicompartment compact, as shown and described.

DESCRIPTION

FIG. 1 is a perspective view of a compact showing our new design;
FIG. 2 is a top plan view thereof;
FIG. 3 is a front elevational view thereof;
FIG. 4 is a rear elevational view thereof;
FIG. 5 is a side elevational view thereof;
FIG. 6 is a bottom plan view thereof; and
FIG. 7 is an exploded perspective view of our design showing the compact in an opened condition.

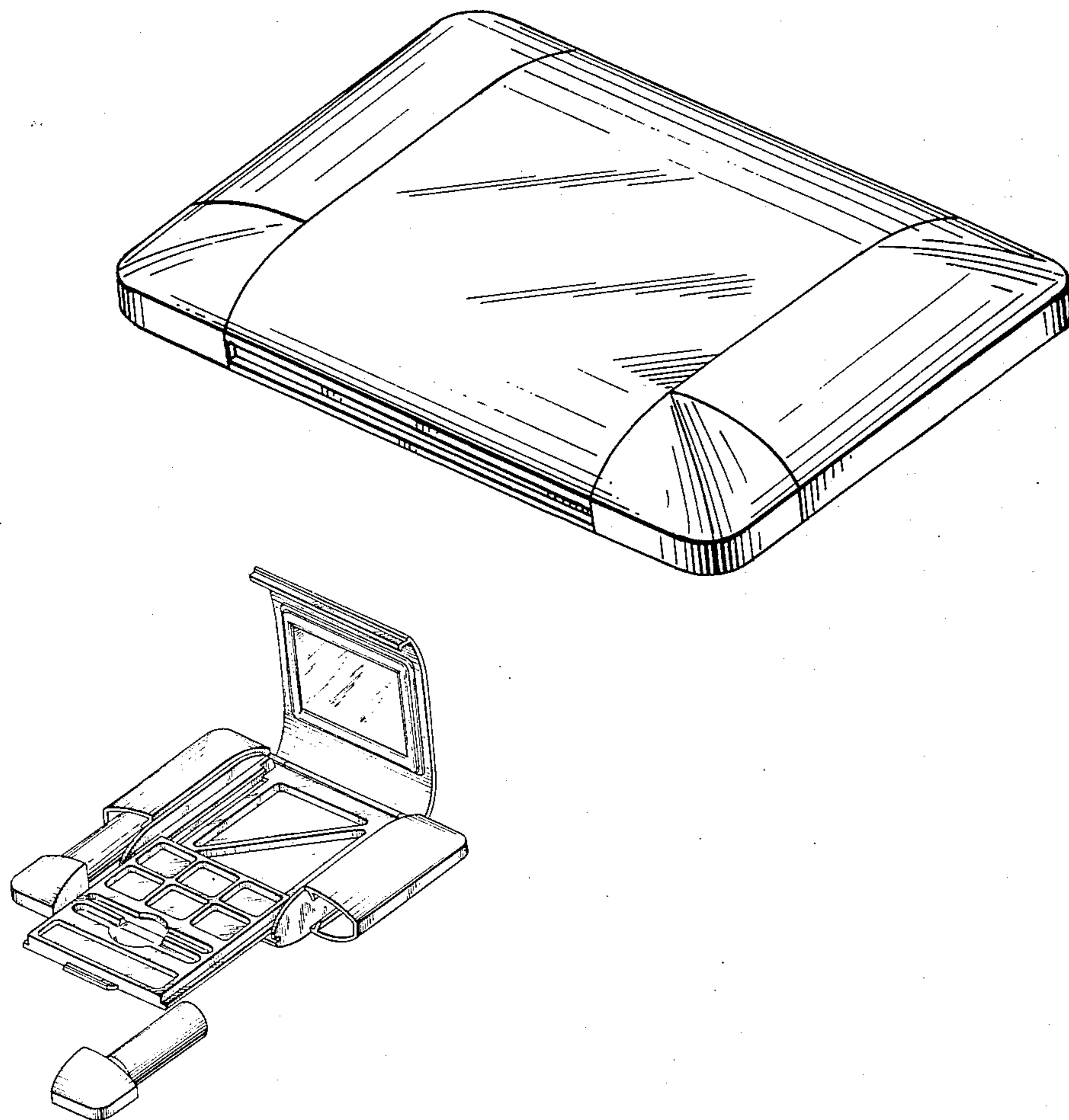

FIG.1

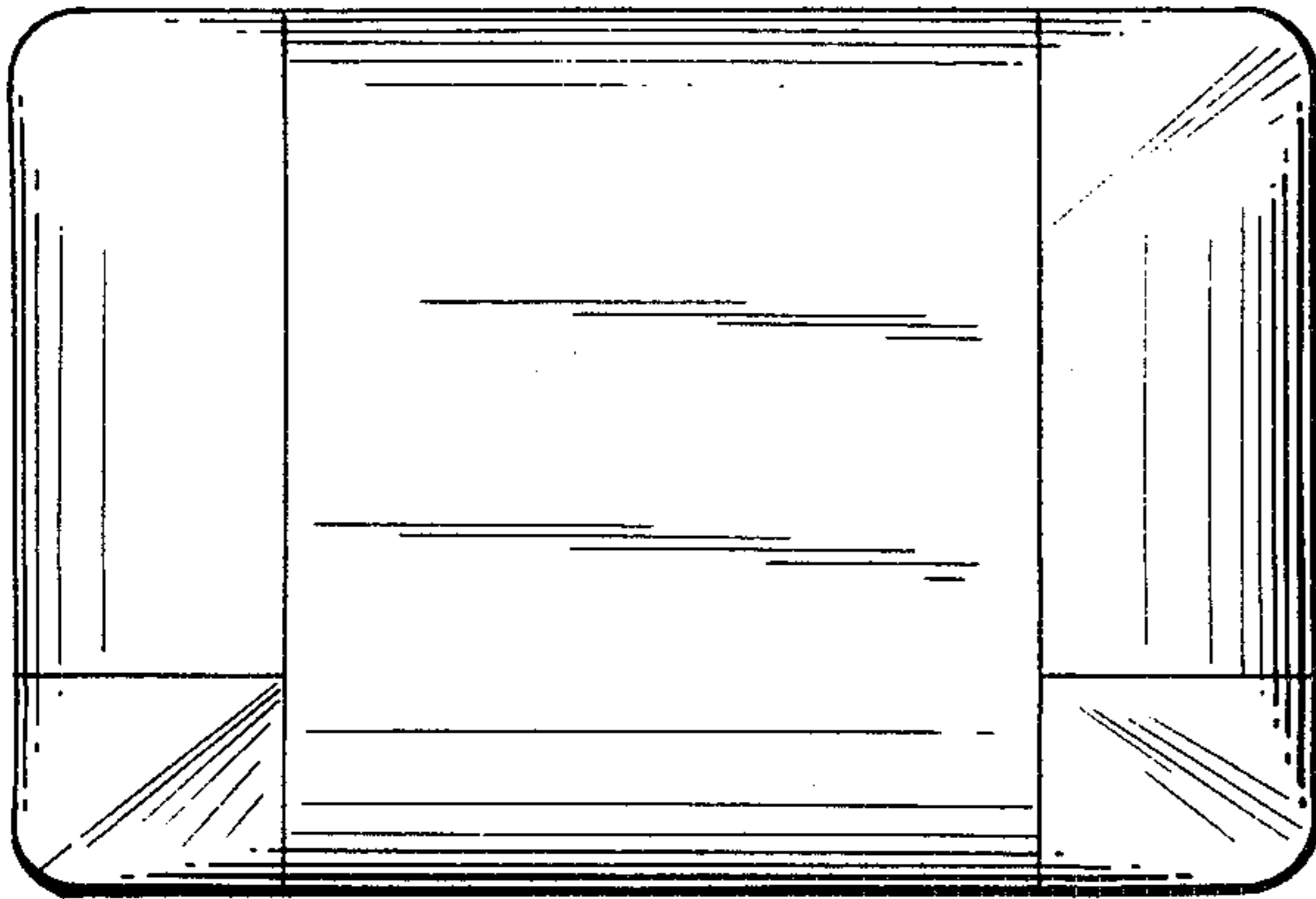
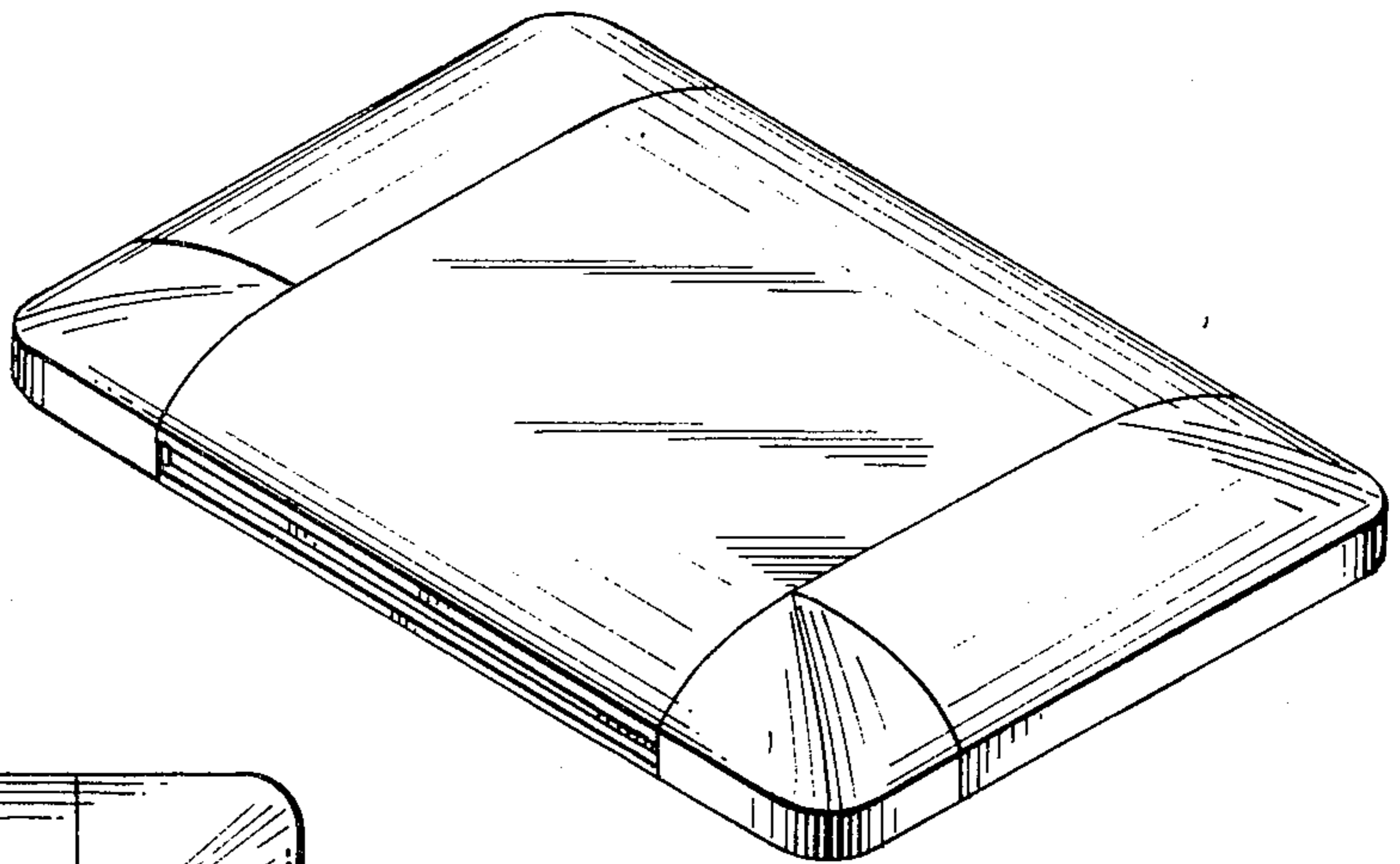

FIG.2

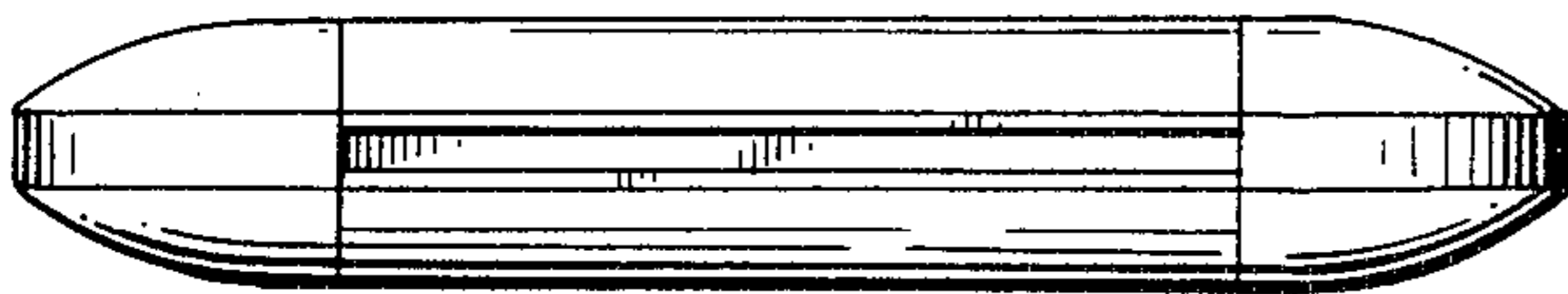

FIG.3

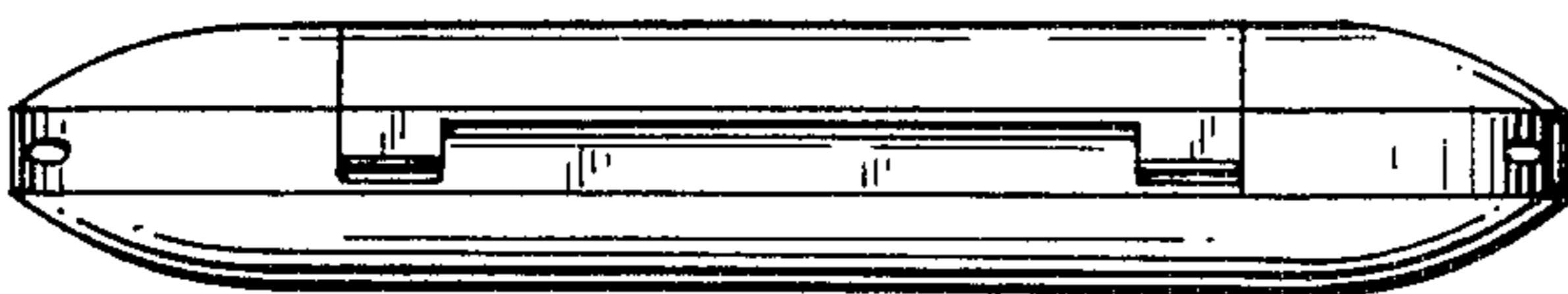

FIG.4

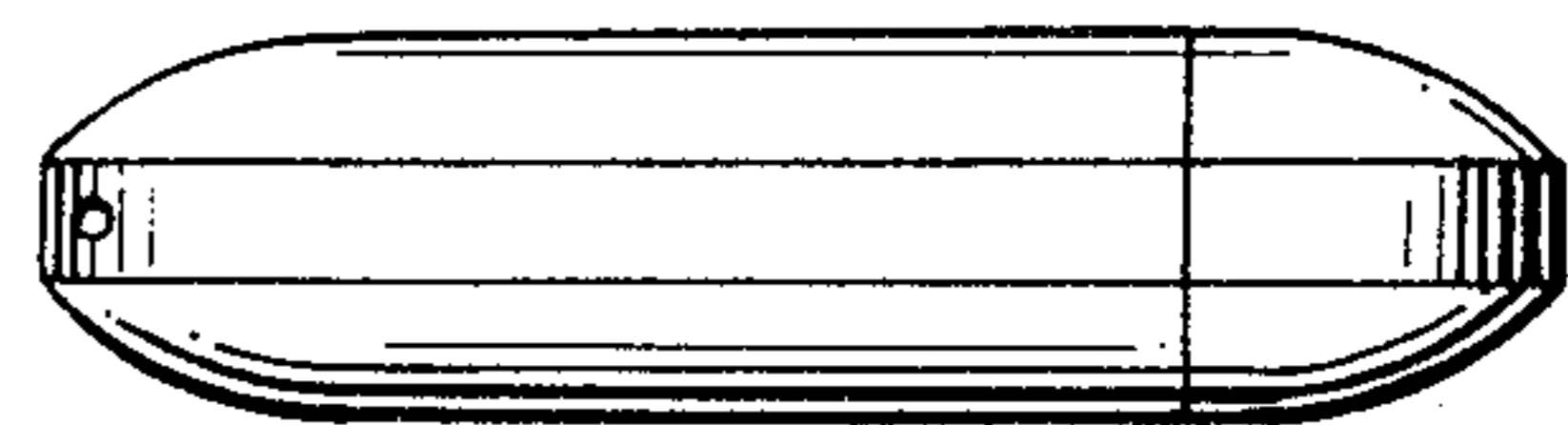

FIG.5

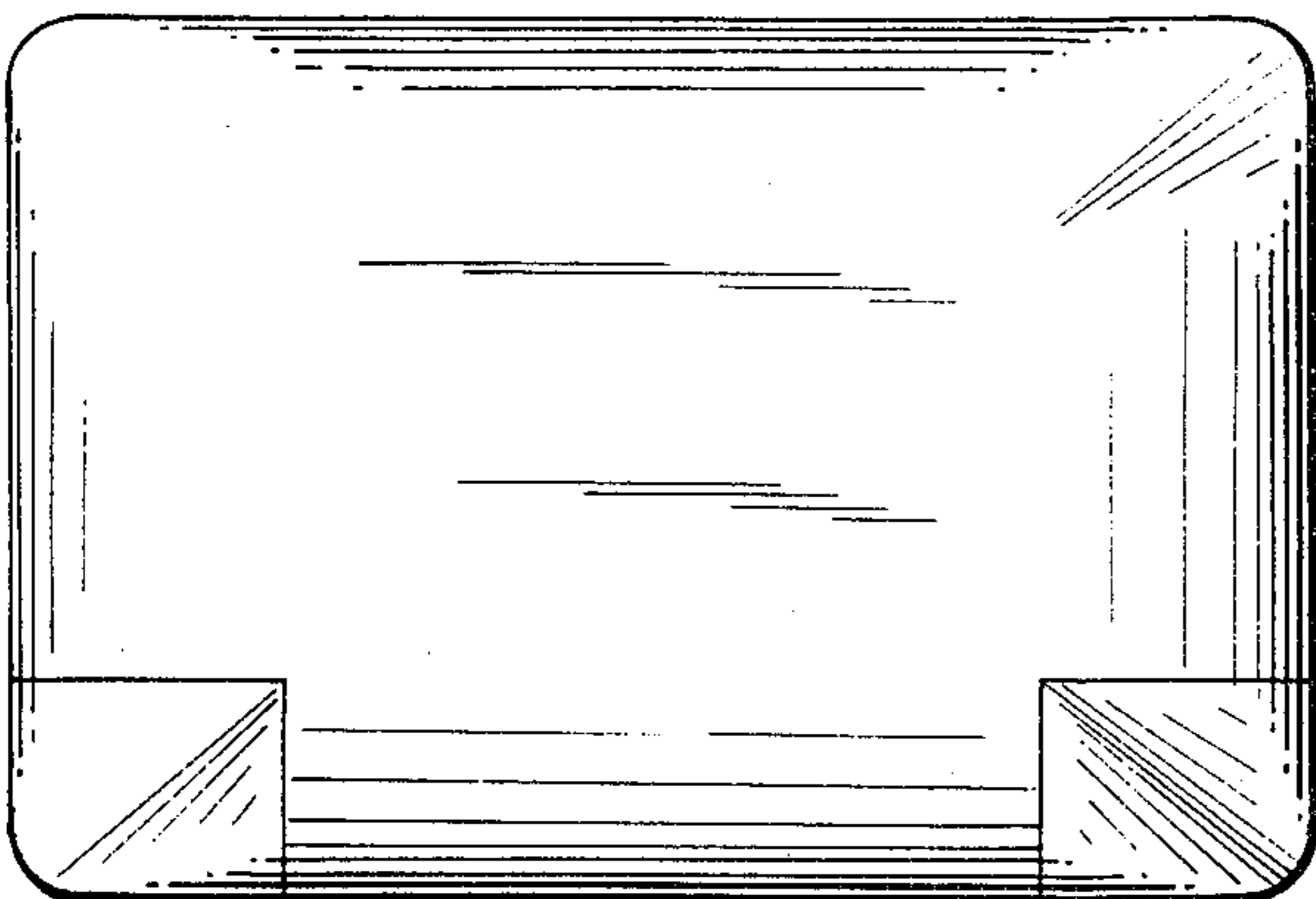

FIG.6

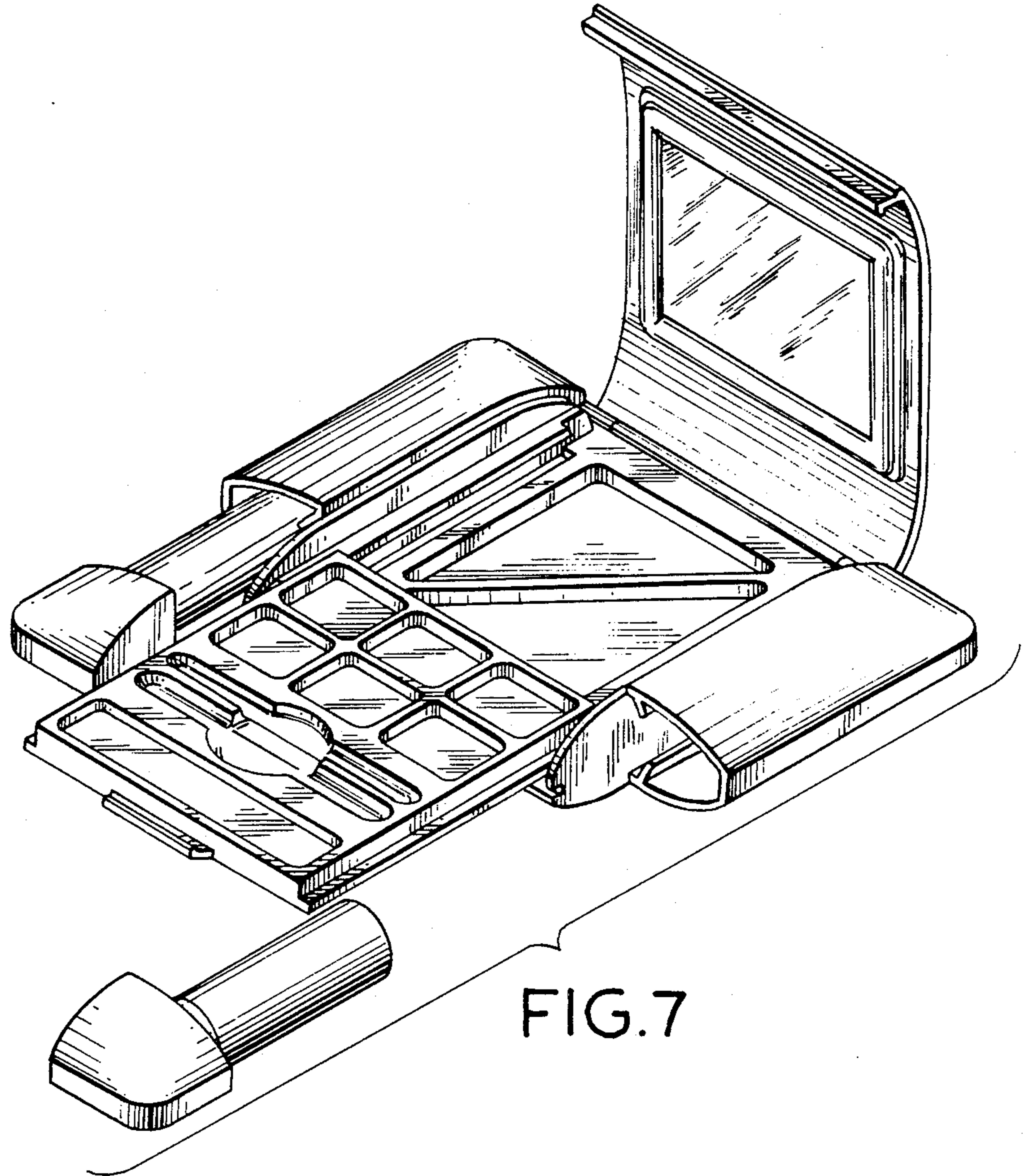

FIG. 7