

[54] OUTBOARD ENGINE

D. 224,758 9/1972 Kitovich D15/4
D. 233,801 11/1974 Giacosa D15/4

[75] Inventors: Yoshio Mikado, Saitama; Jun Ito; Masayuki Ohsumi, both of Tokyo, all of Japan

OTHER PUBLICATIONS

Johnson Engine Catalogue, p. 24, "Johnson 2".

[73] Assignee: Honda Giken Kogyo Kabushiki Kaisha, Tokyo, Japan

Primary Examiner—Wallace R. Burke
Assistant Examiner—Brian N. Vinson
Attorney, Agent, or Firm—Sughrue, Mion, Zinn, Macpeak & Seas

[**] Term: 14 Years

[21] Appl. No.: 595,152

[57] CLAIM

The ornamental design for an outboard engine, as shown.

[22] Filed: Mar. 30, 1984

[52] U.S. Cl. D15/4

[58] Field of Search D15/4, 149, 66-67; 440/75-78, 52-53, 900, 79-81

DESCRIPTION

FIG. 1 is a front and right side perspective view of an outboard engine showing our new design; FIG. 2 is a right side elevational view thereof; FIG. 3 is a left side elevational view thereof; FIG. 4 is a top plan view thereof; FIG. 5 is a bottom plan view thereof; FIG. 6 is a front elevational view thereof; and FIG. 7 is a rear elevational view thereof.

[56] References Cited

U.S. PATENT DOCUMENTS

- D. 175,270 8/1955 Painter D15/4
- D. 195,797 7/1963 Andersson-Sason D15/4
- D. 200,367 2/1965 Andersson-Sason D15/4
- D. 219,486 12/1970 Lovegreen D15/4

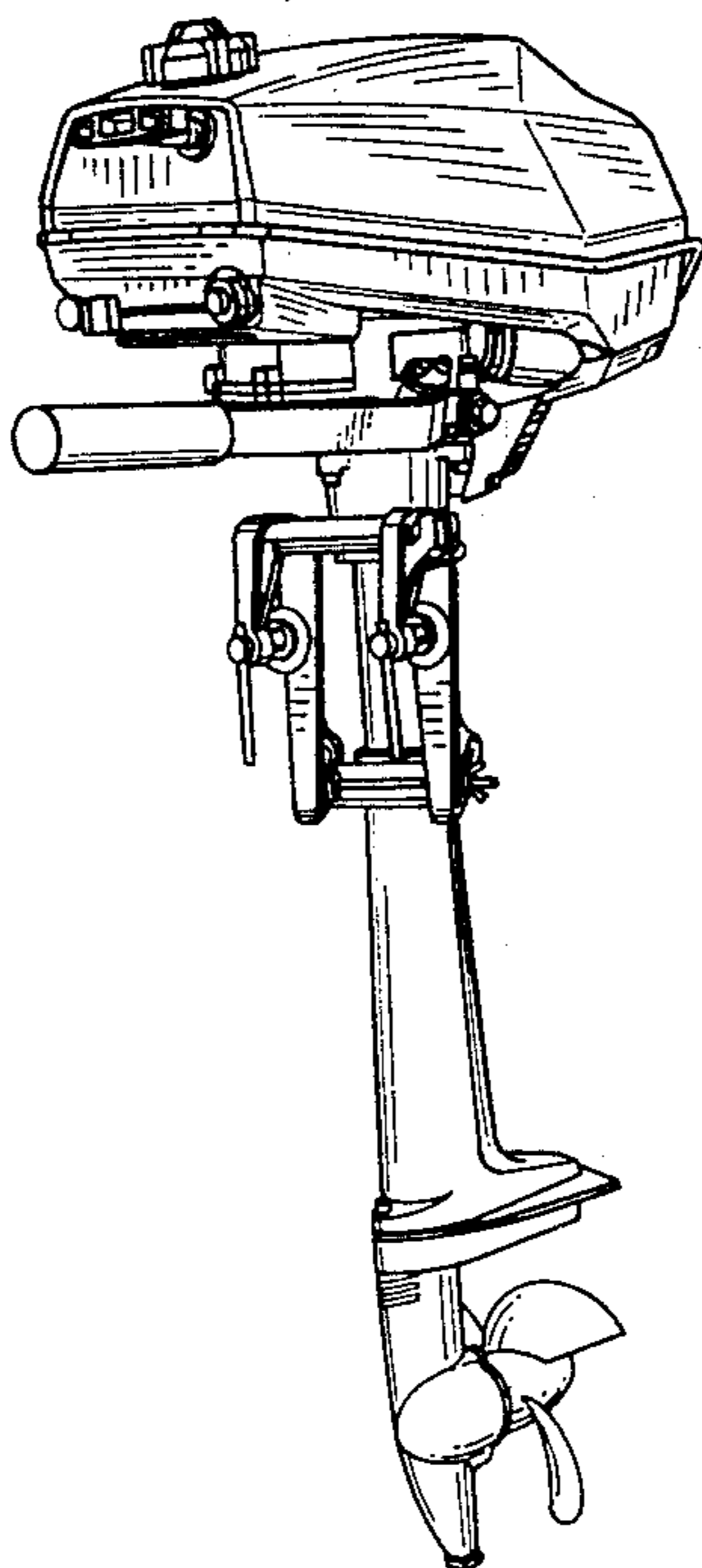

Fig. 1

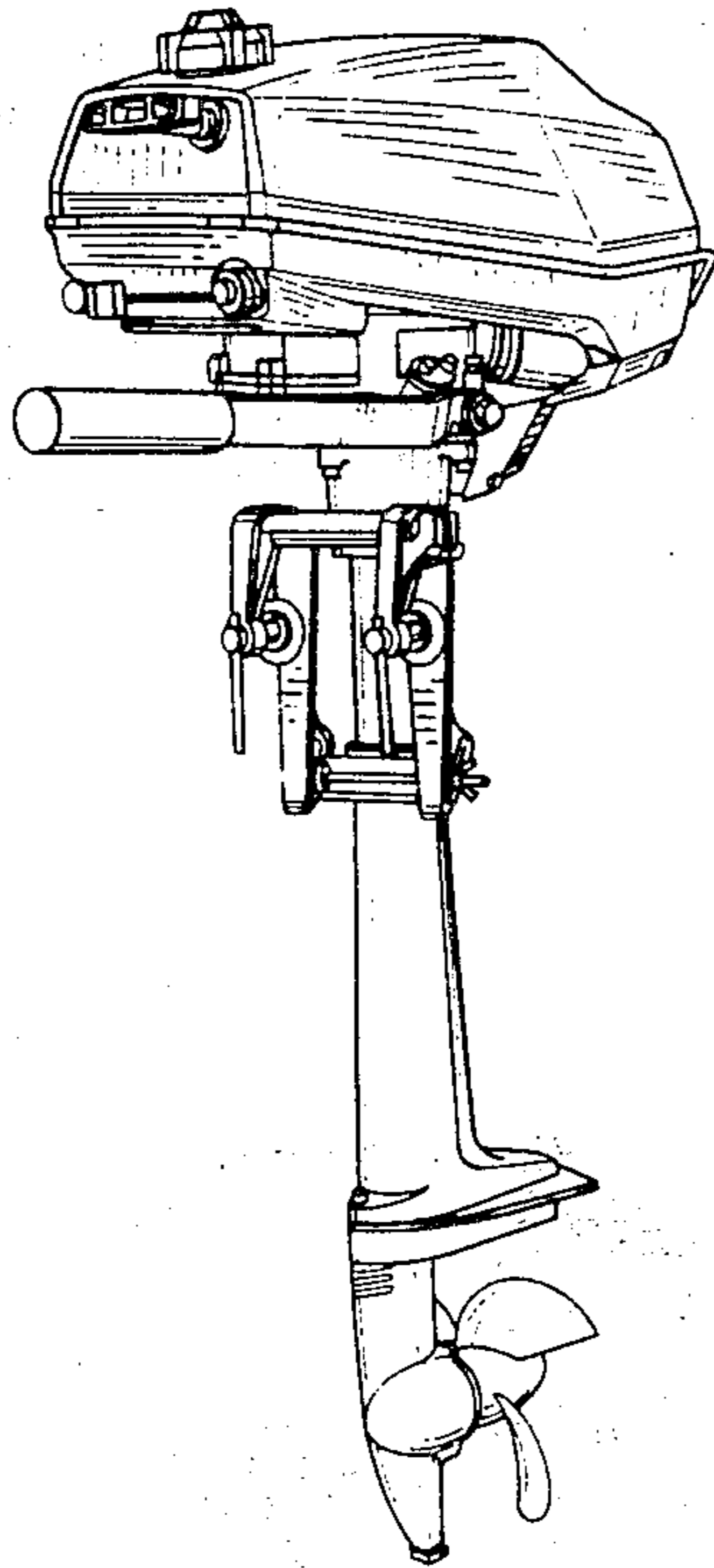

Fig. 2

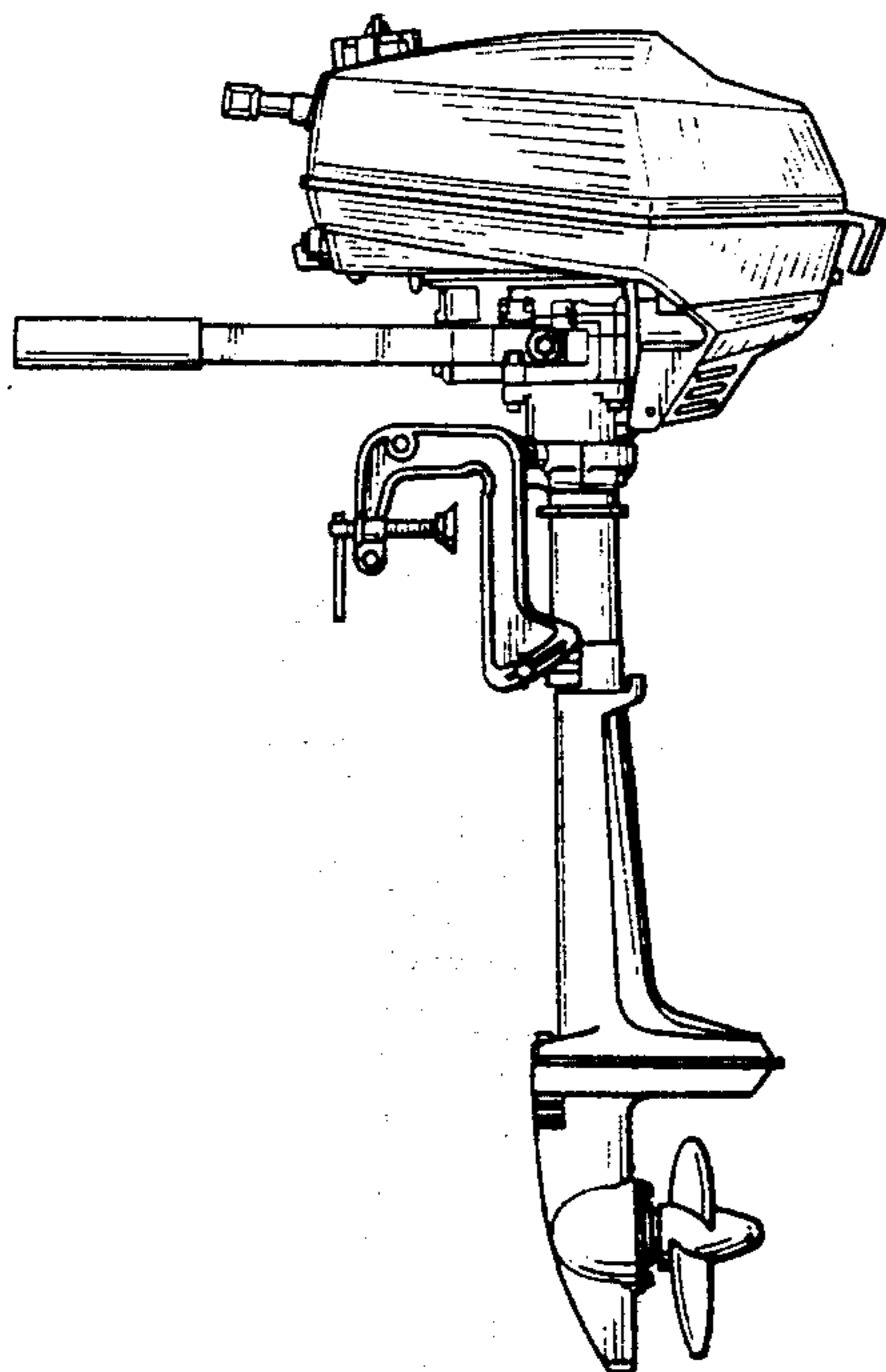

Fig. 3

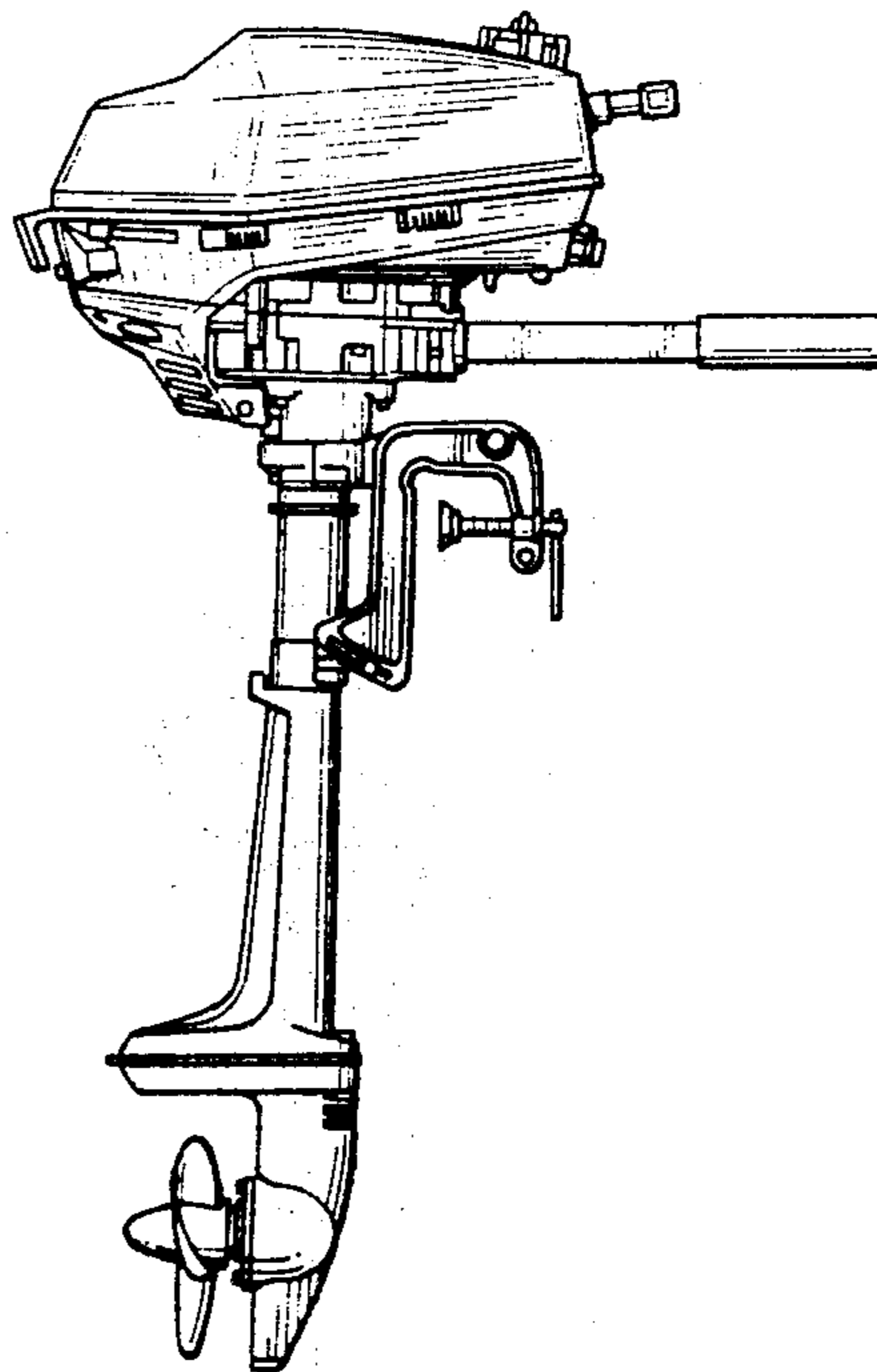

Fig. 4

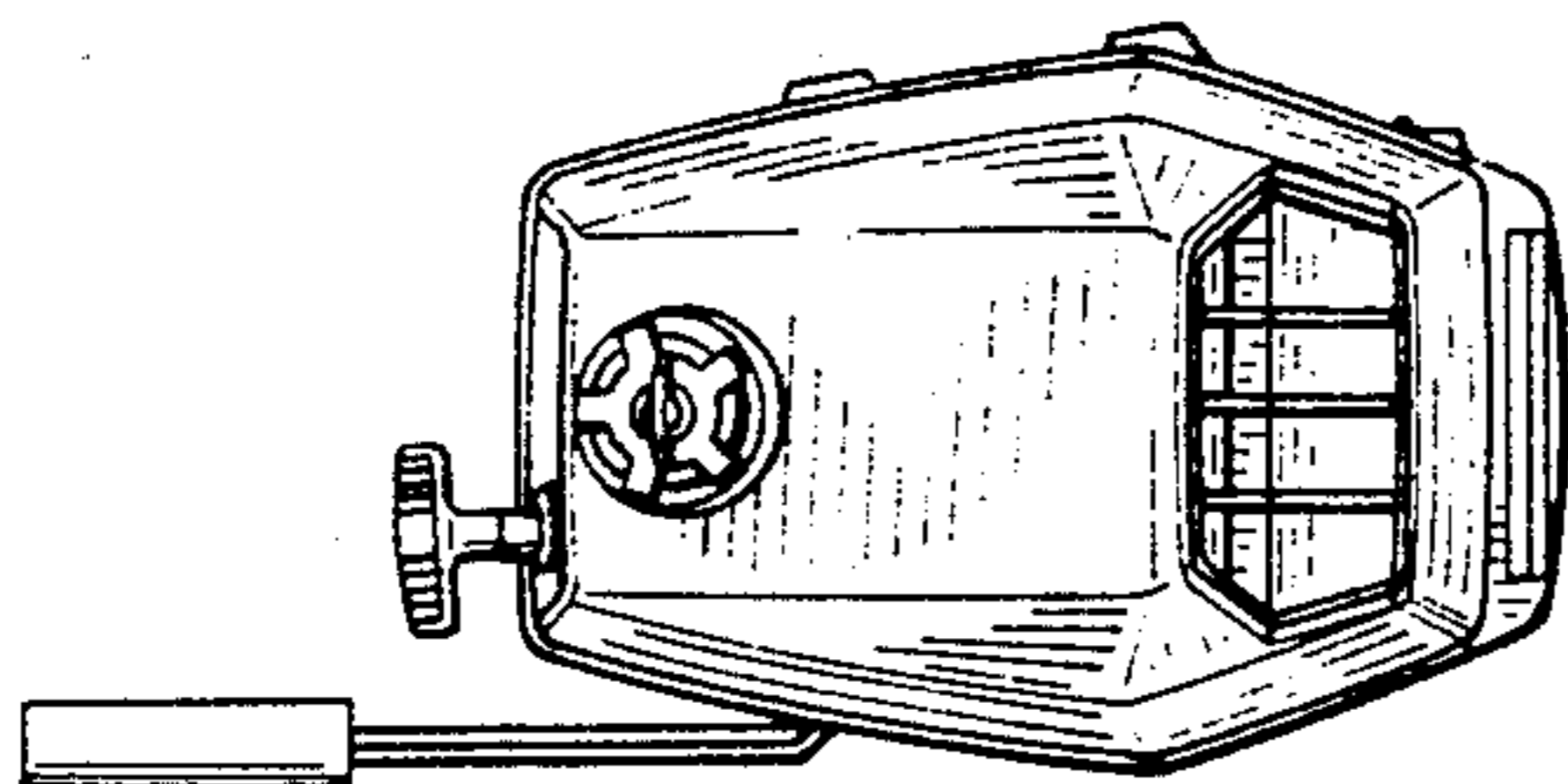

Fig. 5

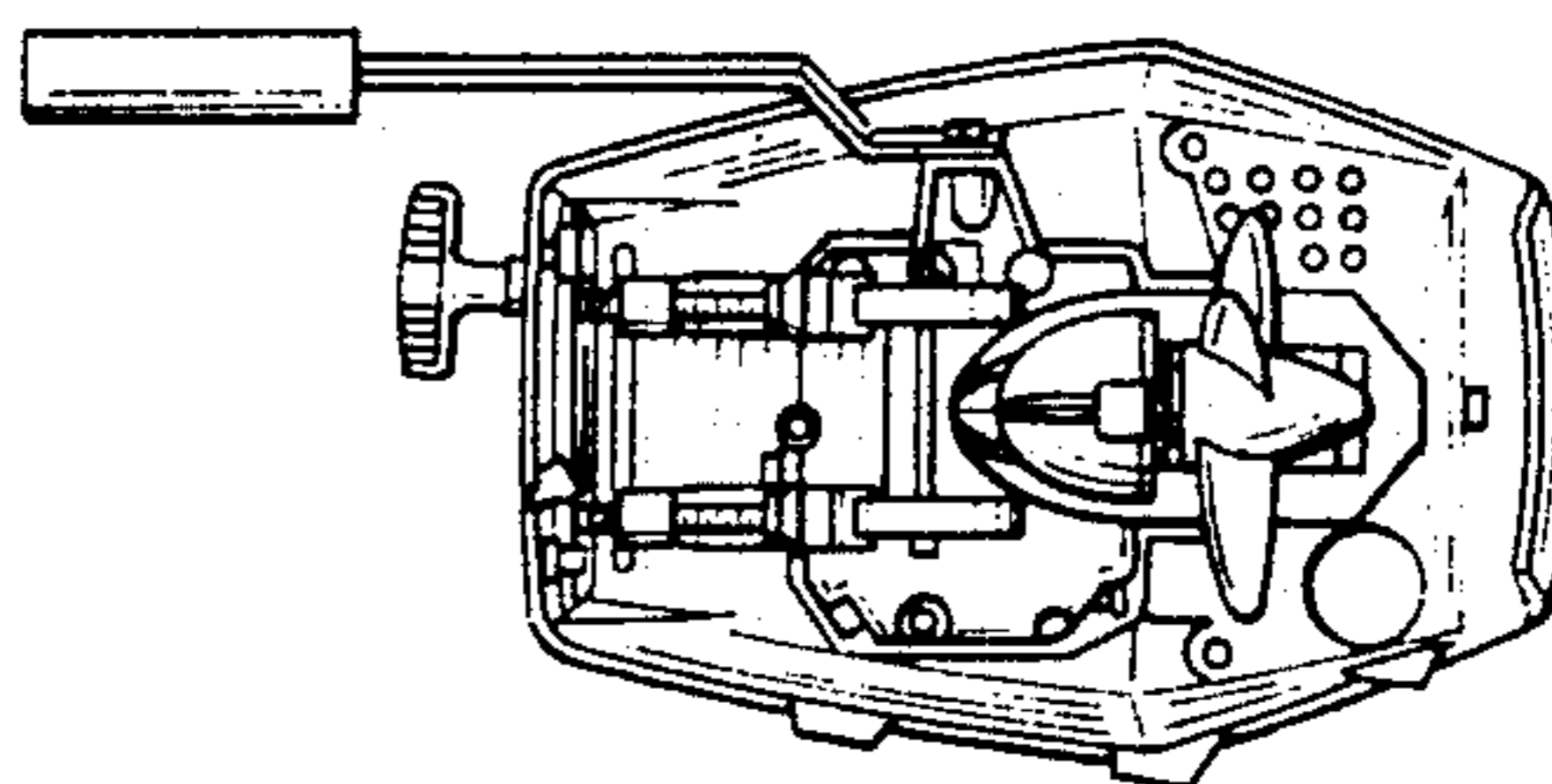

Fig.6

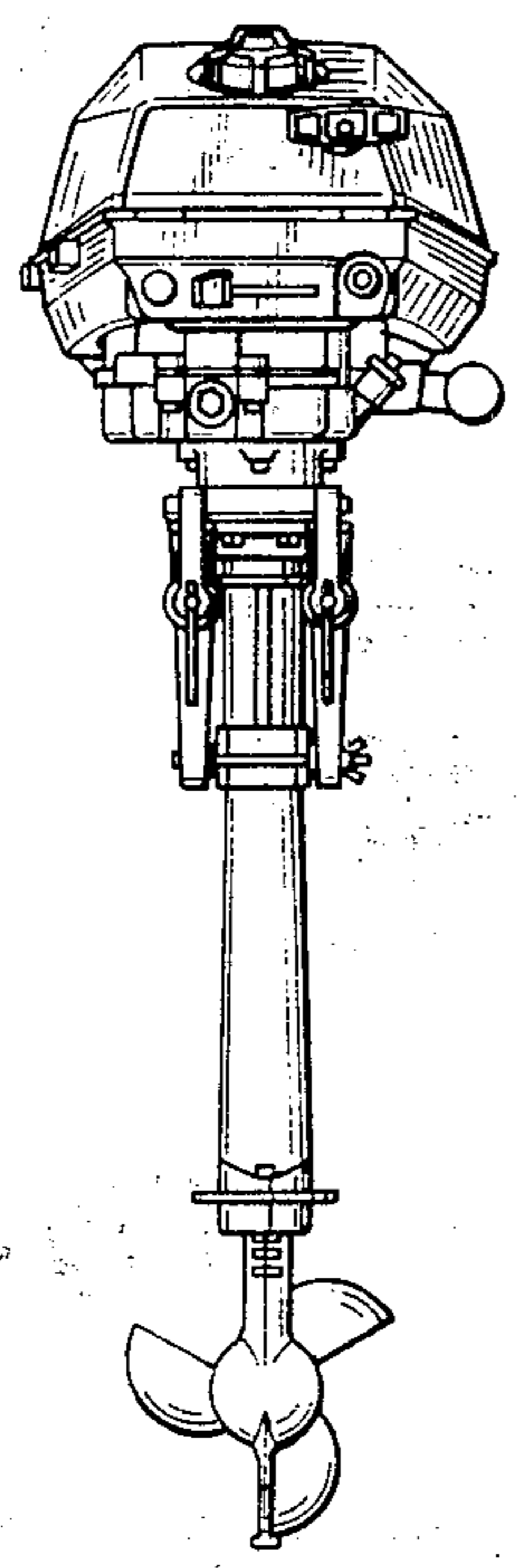

Fig.7

