

[54] BOAT

[75] Inventor: Mark A. Dopps, Sedgwick County, Kans.

[73] Assignee: Ski-Horse Corporation, Wichita, Kans.

[**] Term: 14 Years

[21] Appl. No.: 593,384

[22] Filed: Mar. 26, 1984

[52] U.S. Cl. D12/307; D12/314

[58] Field of Search D12/300, 305, 307, 310, D12/311, 313, 314; 114/270; 440/38, 87, 88, 89

[56] References Cited

U.S. PATENT DOCUMENTS

- D. 223,414 4/1972 LaPointe et al. D12/314
- D. 233,140 10/1974 Tanaka et al. D12/307
- D. 237,956 12/1975 Naito et al. D12/314

D. 241,328 9/1976 Naito et al. D12/307

Primary Examiner—James M. Gandy
Assistant Examiner—Kay H. Chin
Attorney, Agent, or Firm—Kokjer, Kircher, Bradley, Wharton, Bowman & Johnson

[57] CLAIM

The ornamental design for a boat, as shown and described.

DESCRIPTION

FIG. 1 is a front perspective view of a boat embodying my new design;
FIG. 2 is a rear perspective view thereof;
FIG. 3 is a side elevational view thereof, the opposite side being a mirror image of that shown.
FIG. 4 is a top plan view thereof;
FIG. 5 is a bottom plan view thereof;
FIG. 6 is a front elevational view thereof; and
FIG. 7 is a rear elevational view thereof.

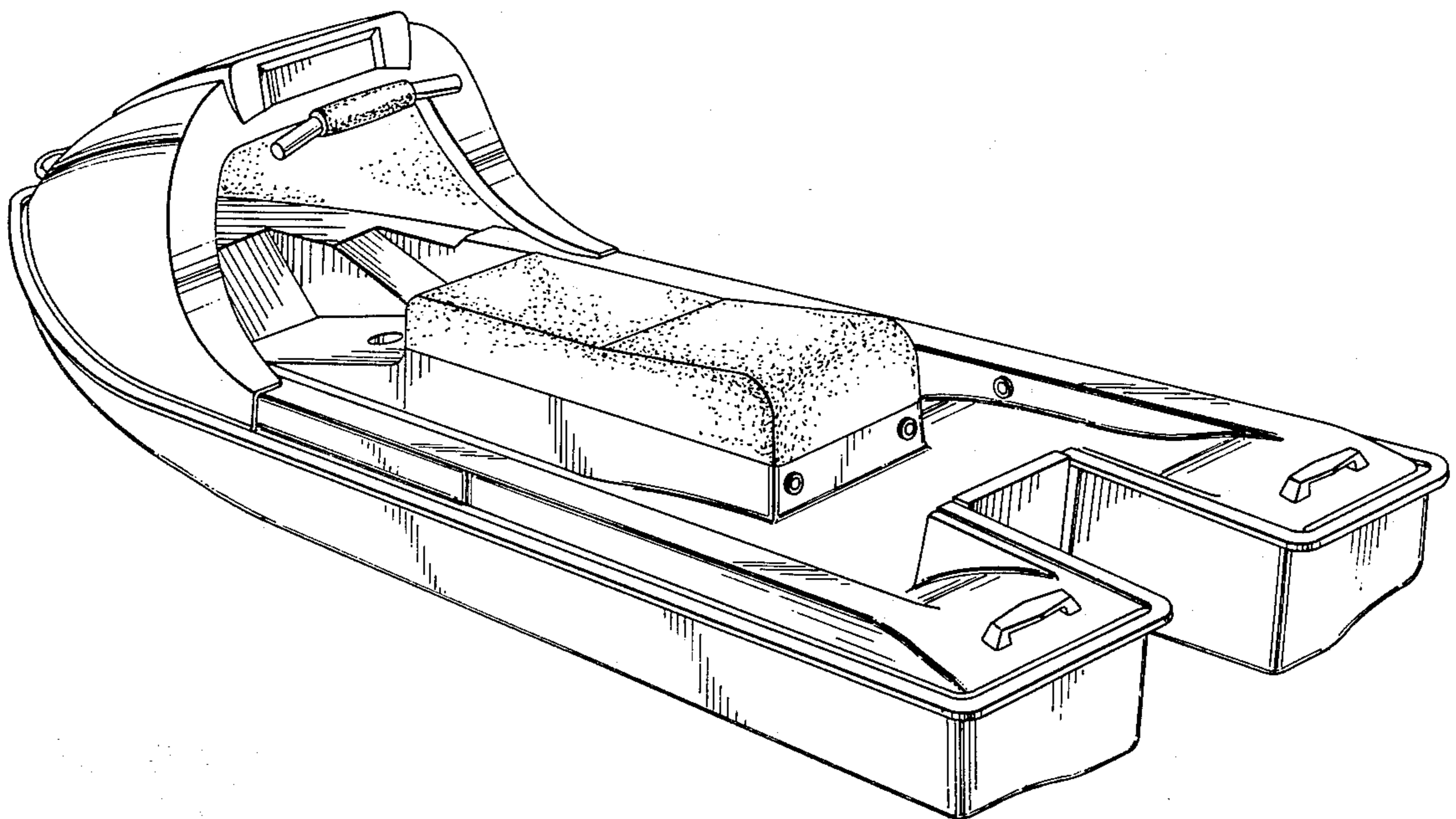

Fig. 1.

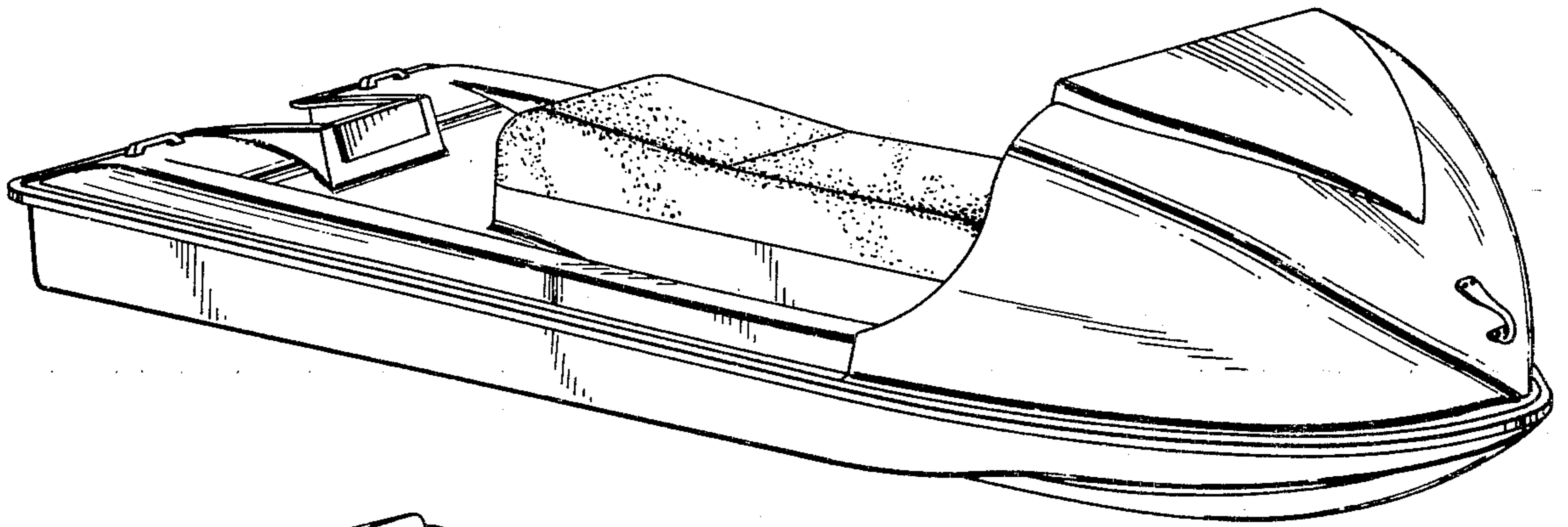

Fig. 2.

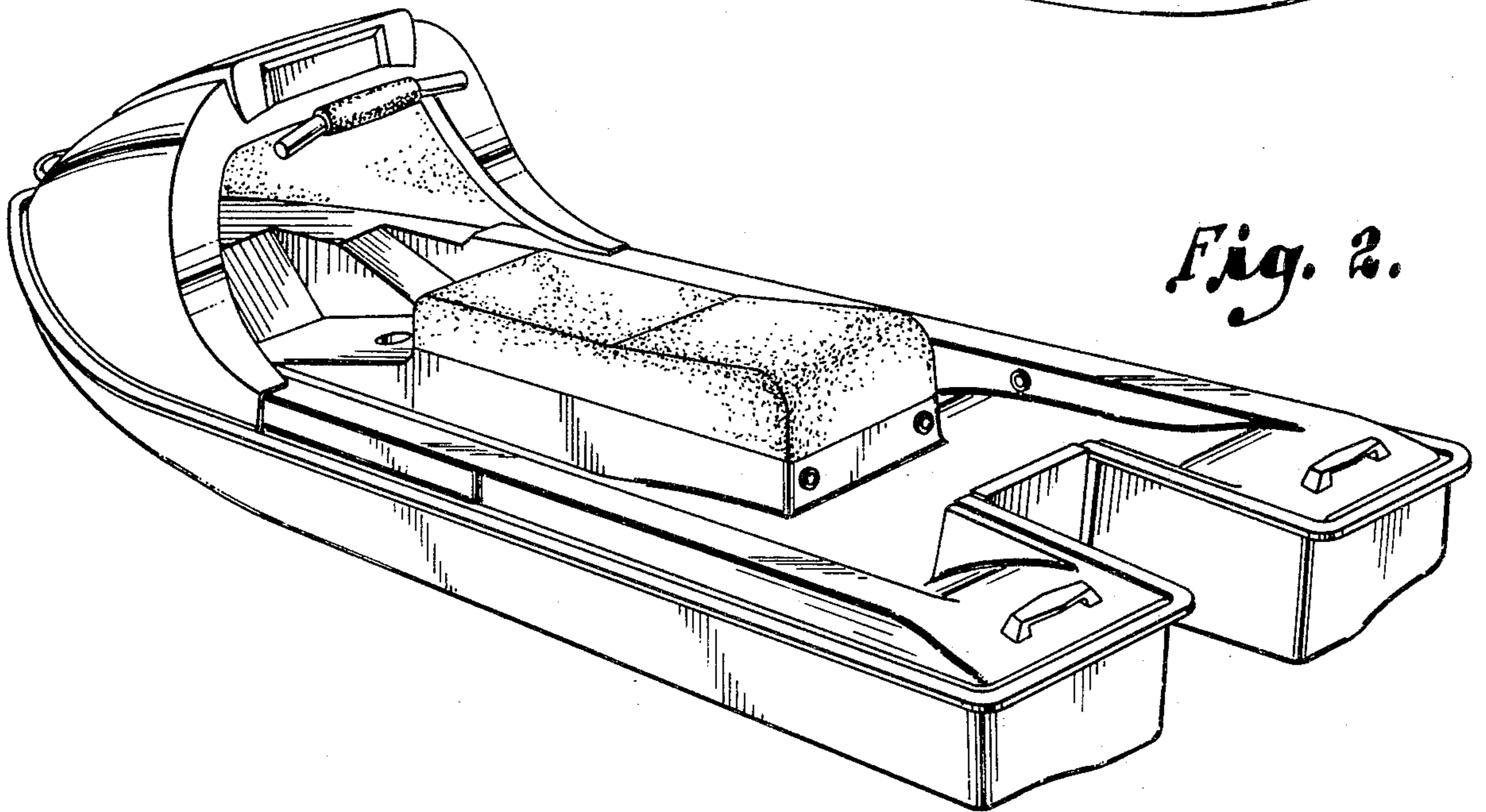

Fig. 3.

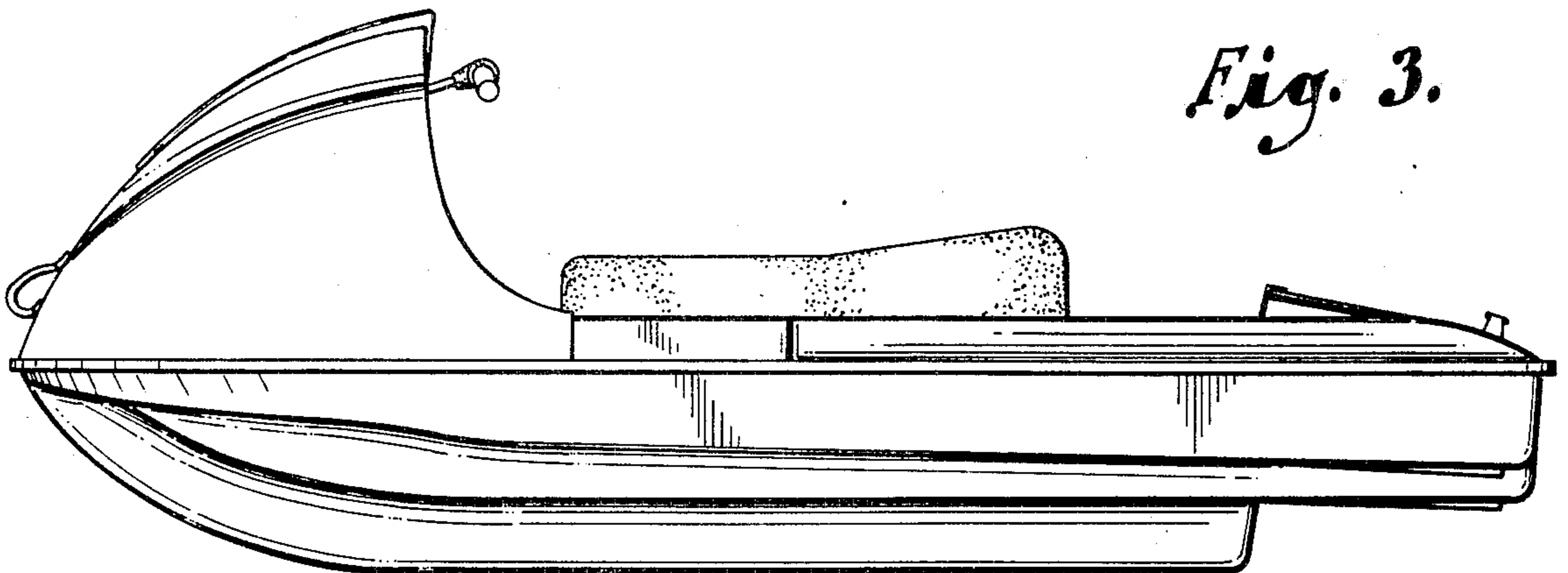

Fig. 4.

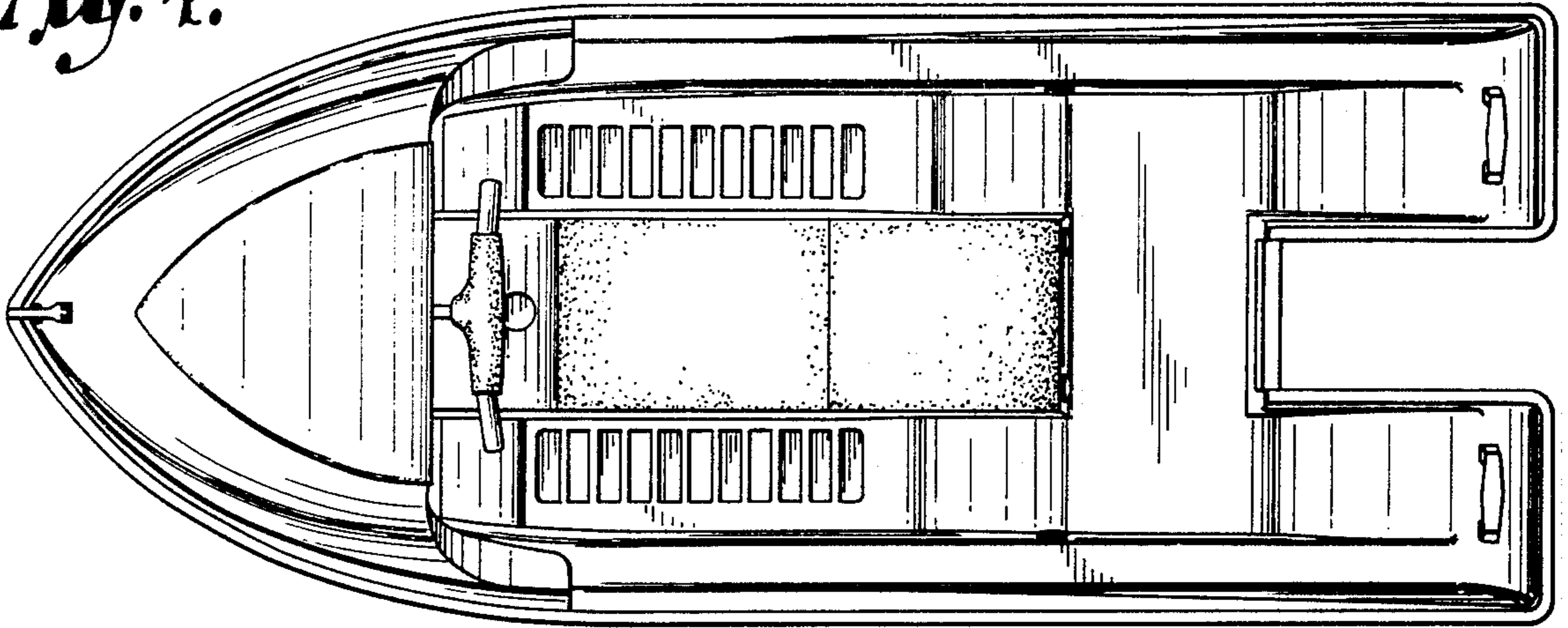

Fig. 5.

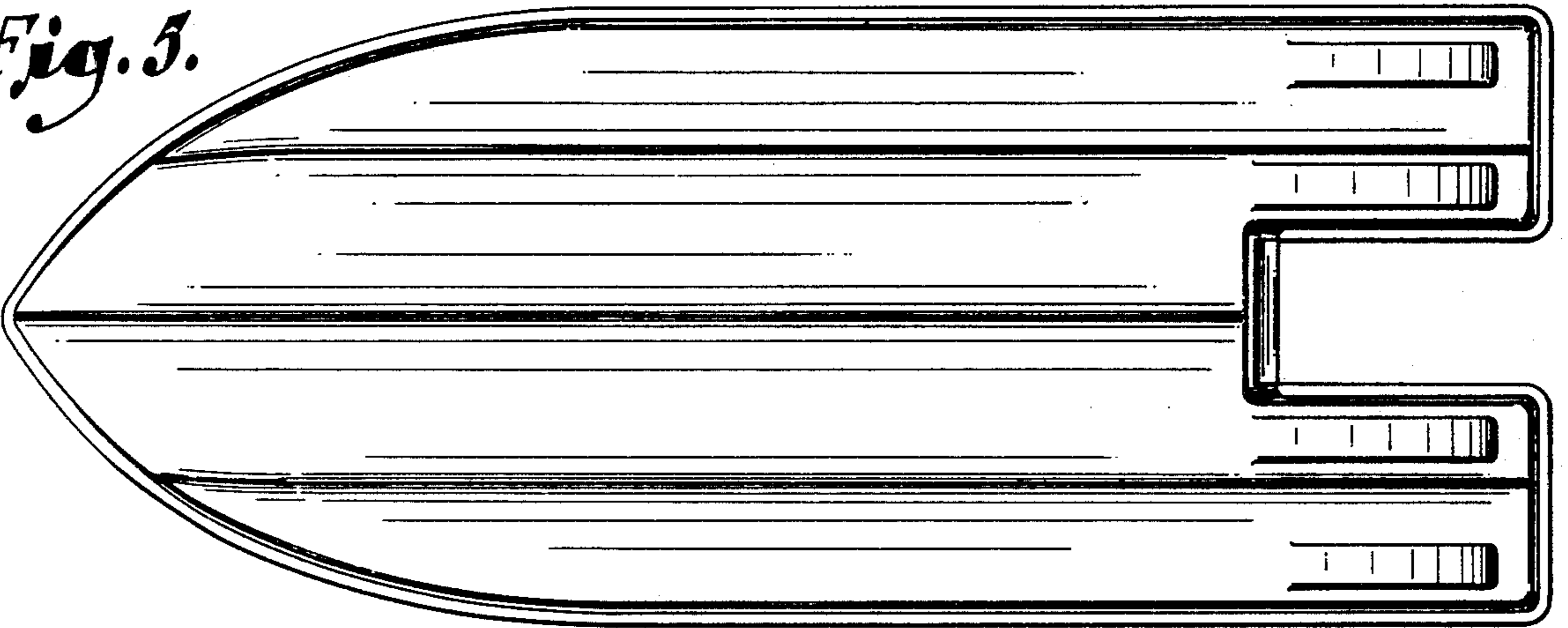

Fig. 6.

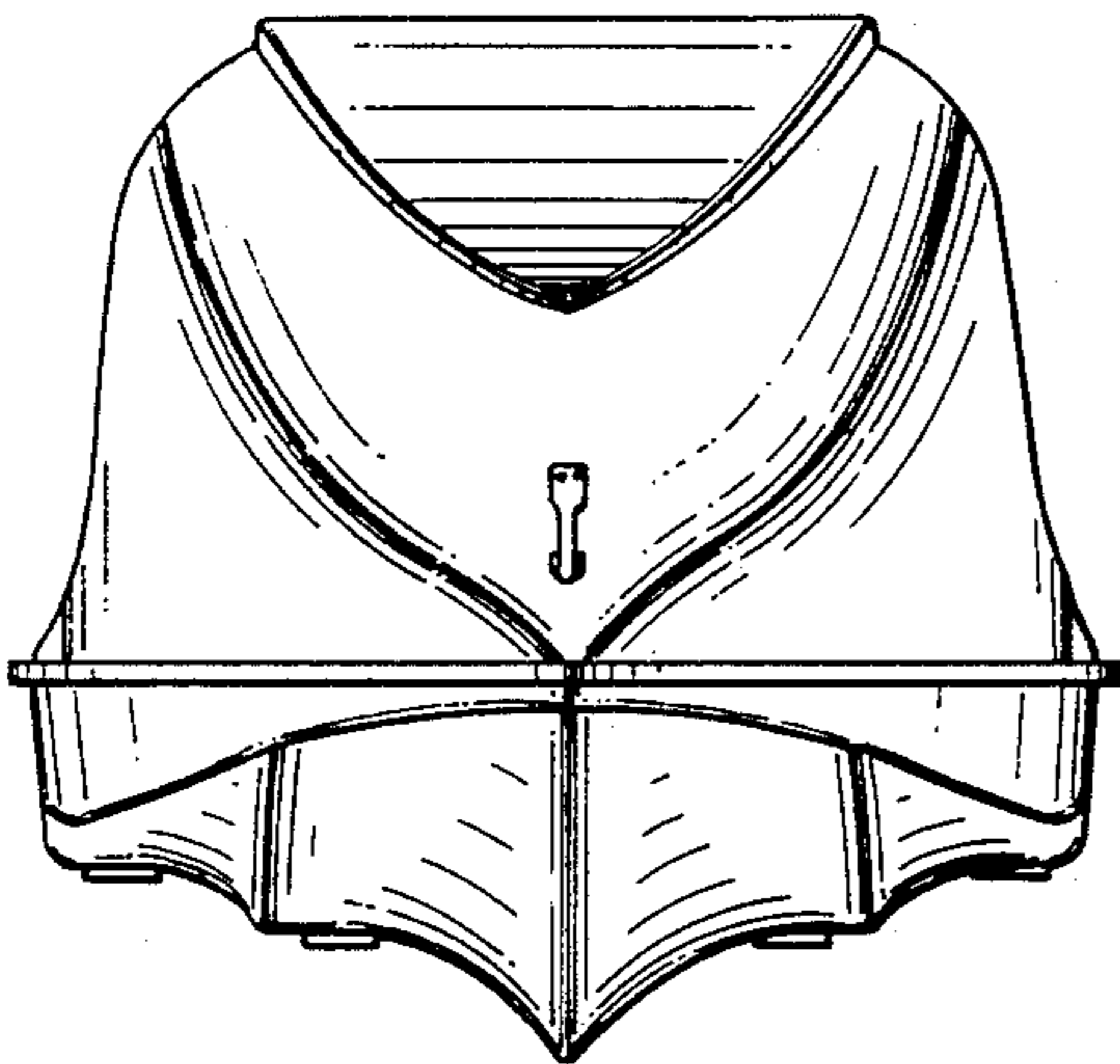

Fig. 7.

