

[54] TRUCK DRIVER CAB

[75] Inventors: Werner Breitschwerdt, Stuttgart; Arthur Mischke, Ostfildern; Bruno Sacco, Sindelfingen, all of Fed. Rep. of Germany

[73] Assignee: Daimler-Benz Aktiengesellschaft, Fed. Rep. of Germany

[**] Term: 14 Years

[21] Appl. No.: 528,955

[22] Filed: Sep. 2, 1983

[30] Foreign Application Priority Data

Mar. 4, 1983 [DE] Fed. Rep. of Germany MR 5607
[52] U.S. Cl. D12/96
[58] Field of Search D12/96, 97; 296/190; 180/89.12, 89.13, 89.16, 89.18, 89.19

[56] References Cited
PUBLICATIONS

Commercial Car Journal, 7/82, P28, Mercedes-Benz Truck Cab, center of page.
Commercial Motor, 3/6/82, P48, Mercedes-Benz Truck Cab.
Commercial Motor, 4/24/82, front cover, Leyland Truck Cab.
Commercial Motor, 3/20/82, P27, Truck Cab, bottom left side of page.

Primary Examiner—James M. Gandy
Attorney, Agent, or Firm—Craig and Burns

[57] CLAIM

The ornamental design for a truck driver cab, as shown and described.

DESCRIPTION

FIG. 1 is a front elevational view of the truck driver cab embodying our novel design;
FIG. 2 is a rear elevational view thereof;
FIG. 3 is a left side elevational view thereof, the right side being a mirror image of that shown;
FIG. 4 is a left front perspective view thereof; and
FIG. 5 is a left rear perspective view thereof.
The top of the truck driver cab is understood to be plain and unornamented.

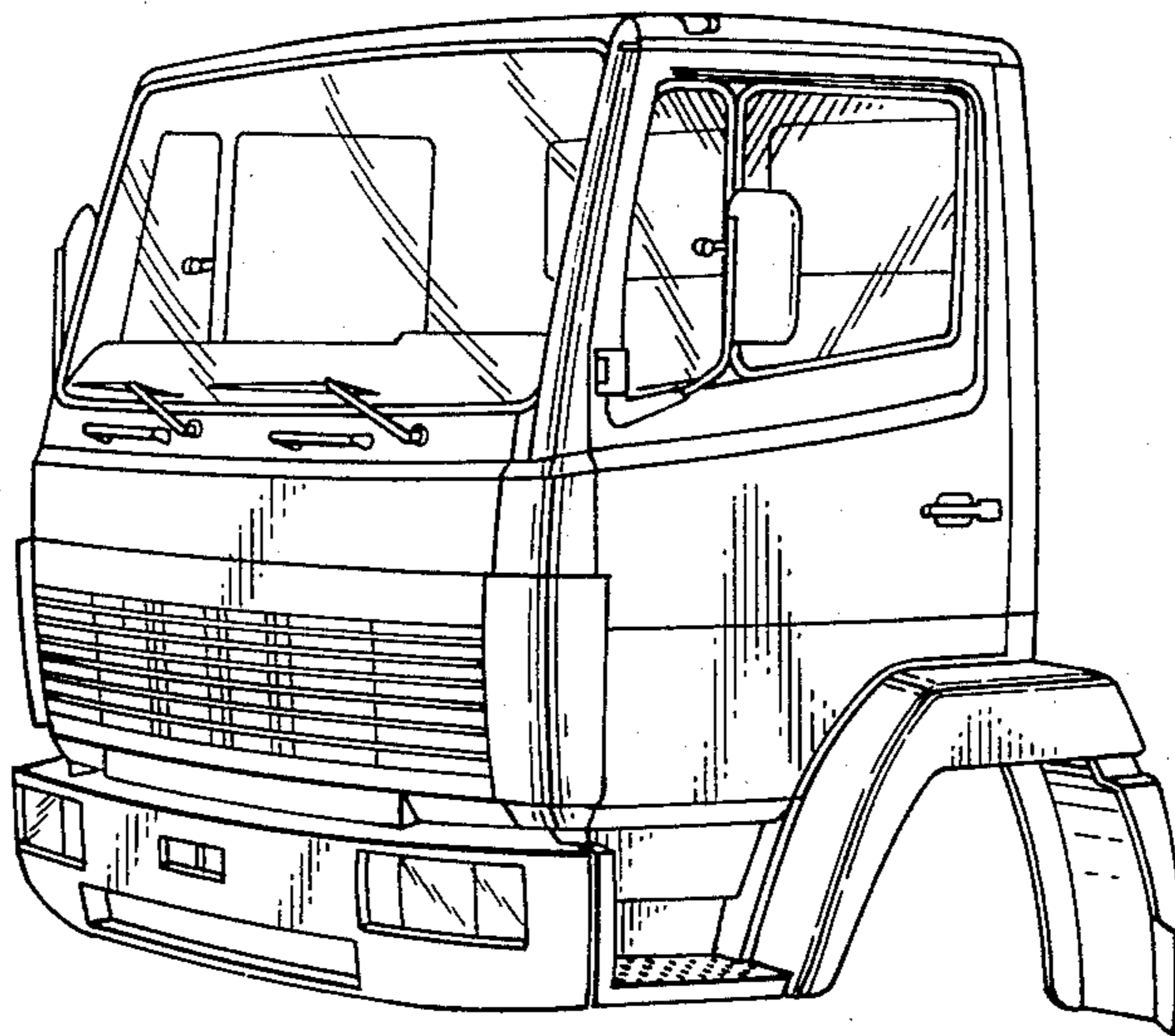

FIG. 1.

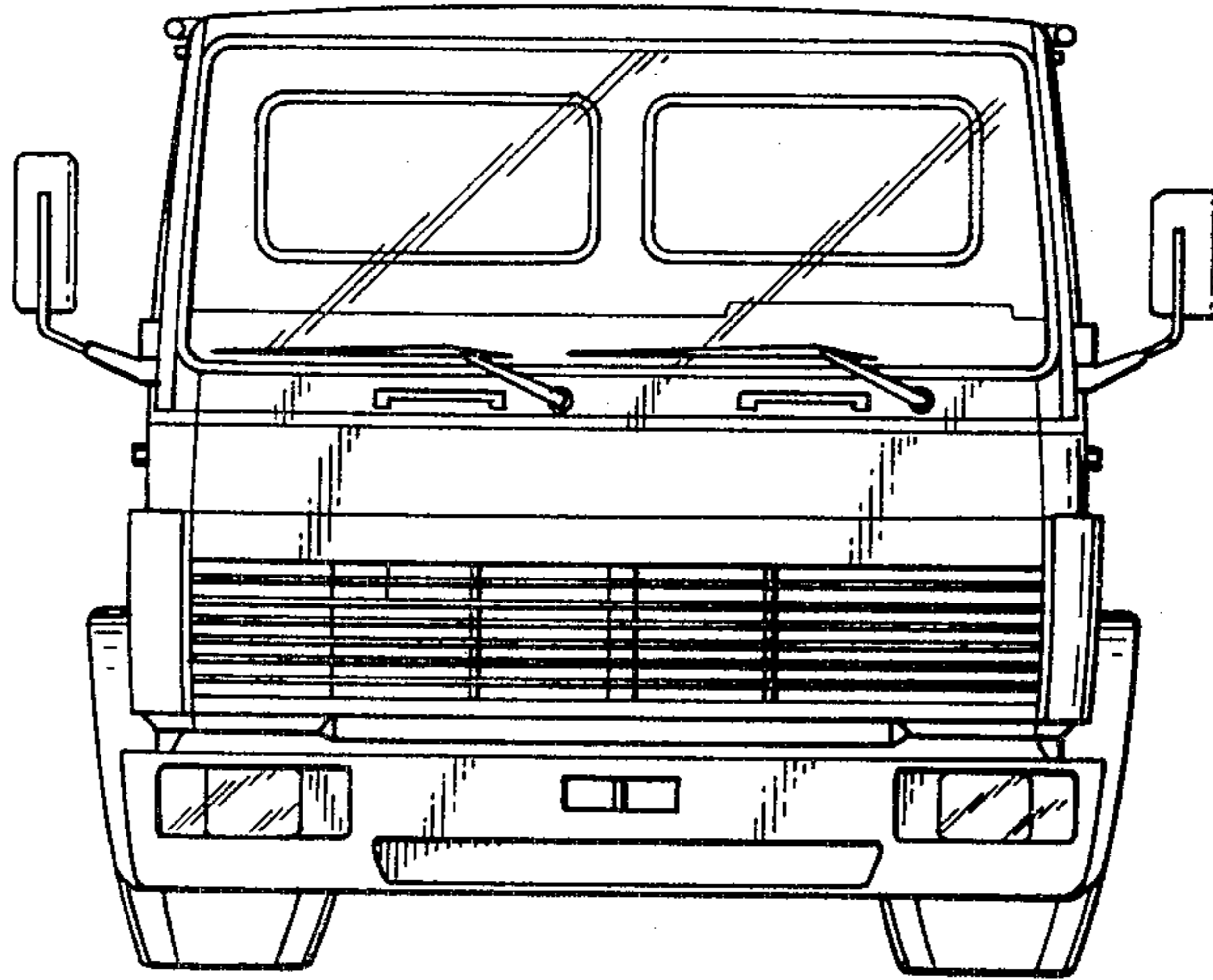

FIG. 2.

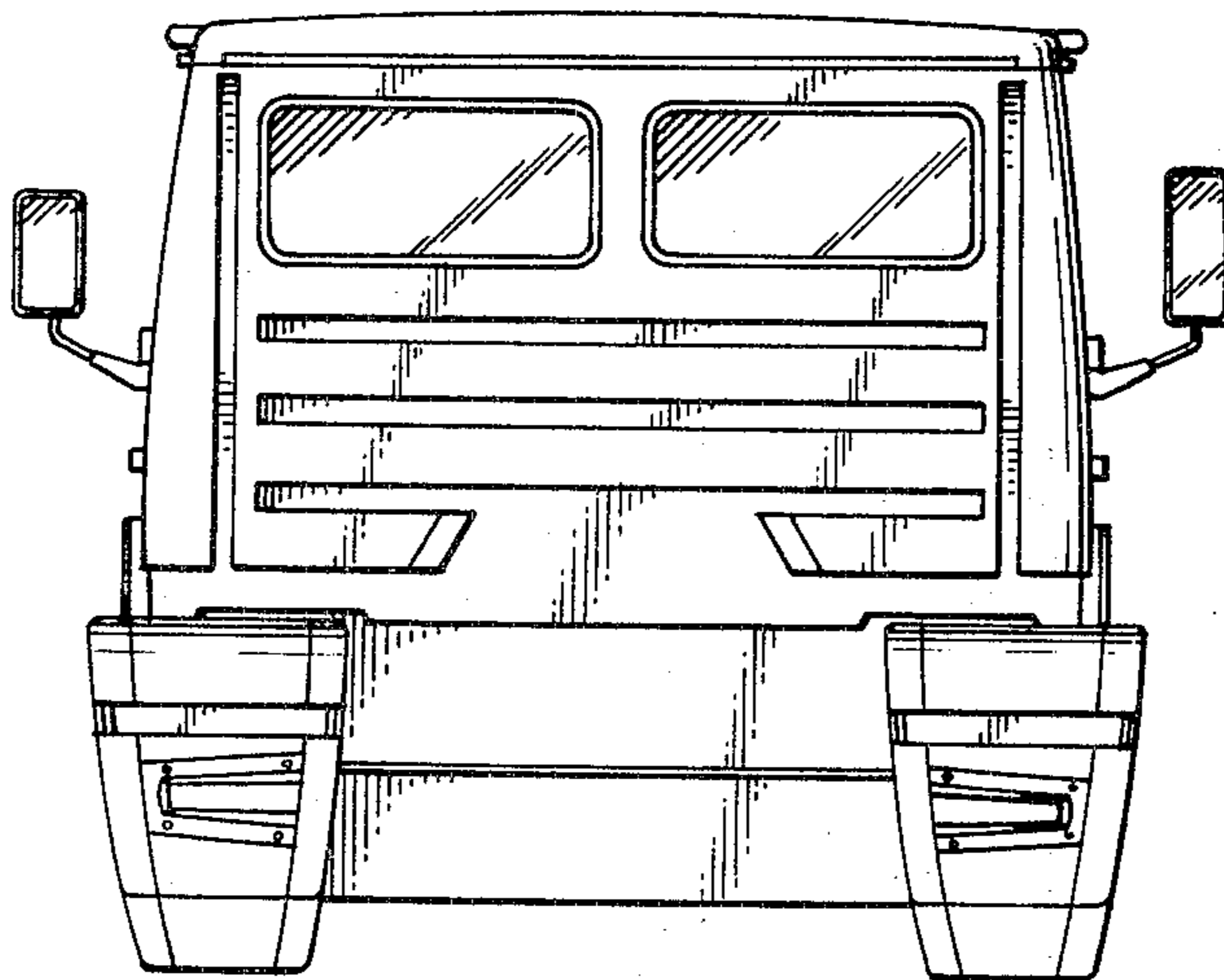

FIG. 3.

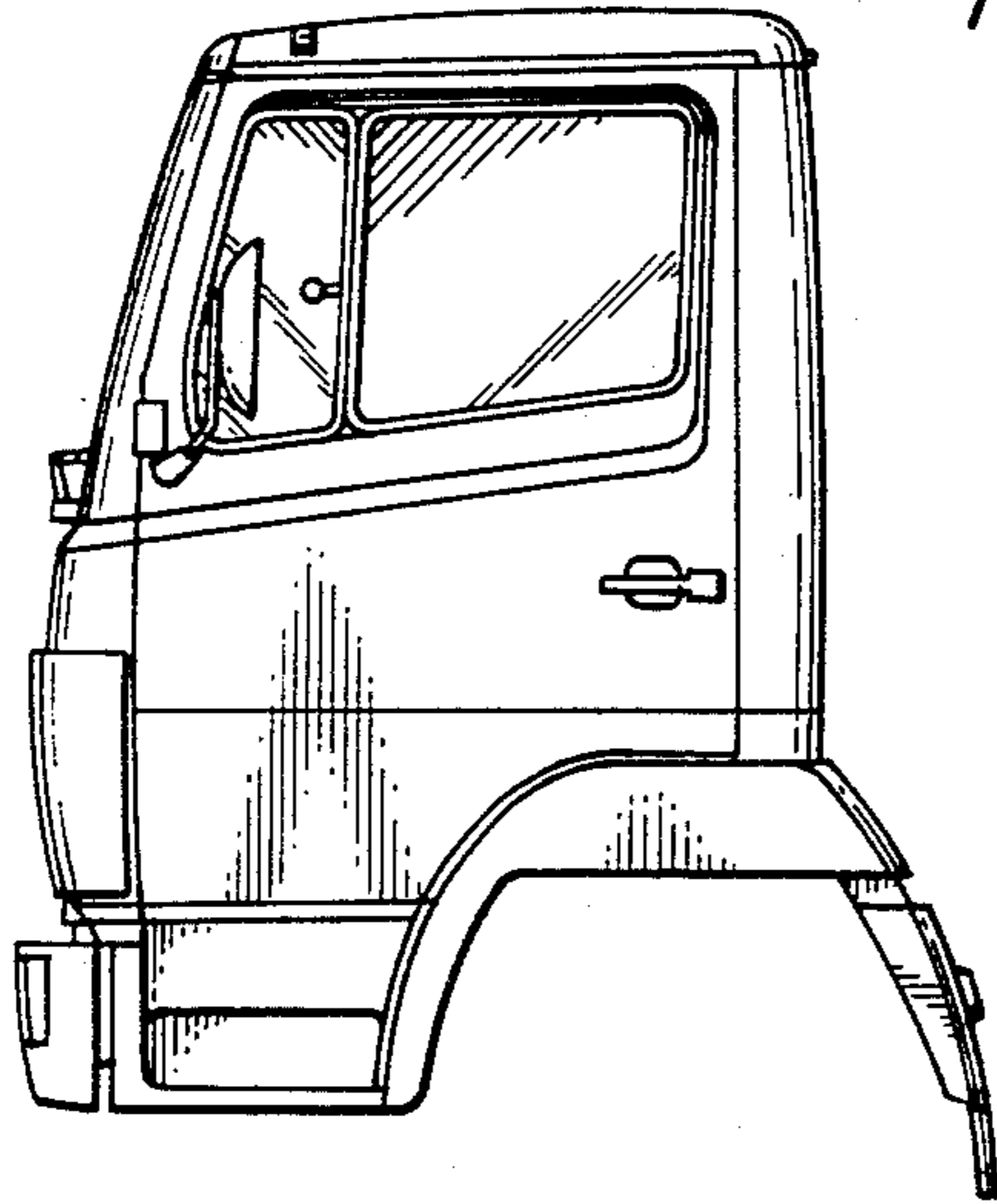

FIG. 4.

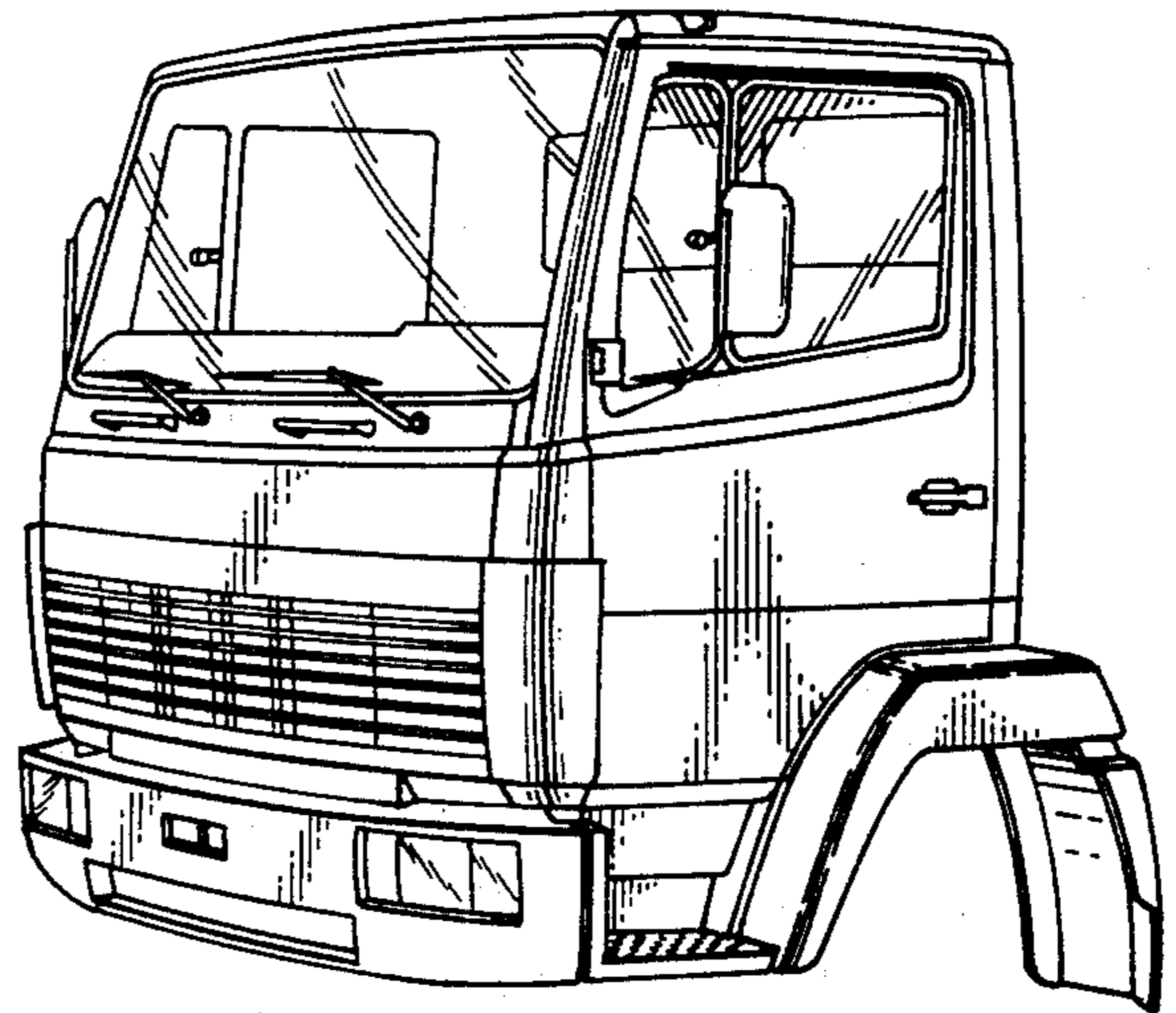

FIG. 5.

