

[54] HEAD LIGHT FOR AN AUTOMOBILE

[56] References Cited

[75] Inventor: Björn E. A. Envall, Vänersborg, Sweden

[73] Assignee: Saab-Scania Aktiebolag, Trollhattan, Sweden

[\*\*] Term: 14 Years

[21] Appl. No.: 603,955

[22] Filed: Apr. 24, 1984

[30] Foreign Application Priority Data

Oct. 26, 1983 [SE]	Sweden	83-2772
[52] U.S. Cl.		D26/28
[58] Field of Search	D26/28, 29, 35, 120, D26/122; 362/61, 80, 81, 82, 83, 326-340, 307, 309, 311	

U.S. PATENT DOCUMENTS

D. 229,507	12/1973	Boano	D26/35
D. 247,991	5/1978	Tixier	D26/122
D. 248,791	8/1978	Tixier	D26/122
D. 271,143	10/1983	Hirakawa	D26/120
D. 271,811	12/1983	Luthe et al.	D26/122
4,198,674	4/1980	Ilhage et al.	362/80
4,475,148	10/1984	Tomforde	362/80 X

Primary Examiner—Susan J. Lucas  
Attorney, Agent, or Firm—Young & Thompson

[57] CLAIM

The ornamental design for a head light for an automobile, as shown and described.

DESCRIPTION

FIG. 1 is a front elevational view of a head light for an automobile, showing my new design; FIG. 2 is a rear perspective view thereof; and FIG. 3 is a top perspective view thereof; FIG. 4 is a bottom perspective view thereof; and FIG. 5 is a side perspective view thereof taken from the side opposite that shown in FIG. 2.

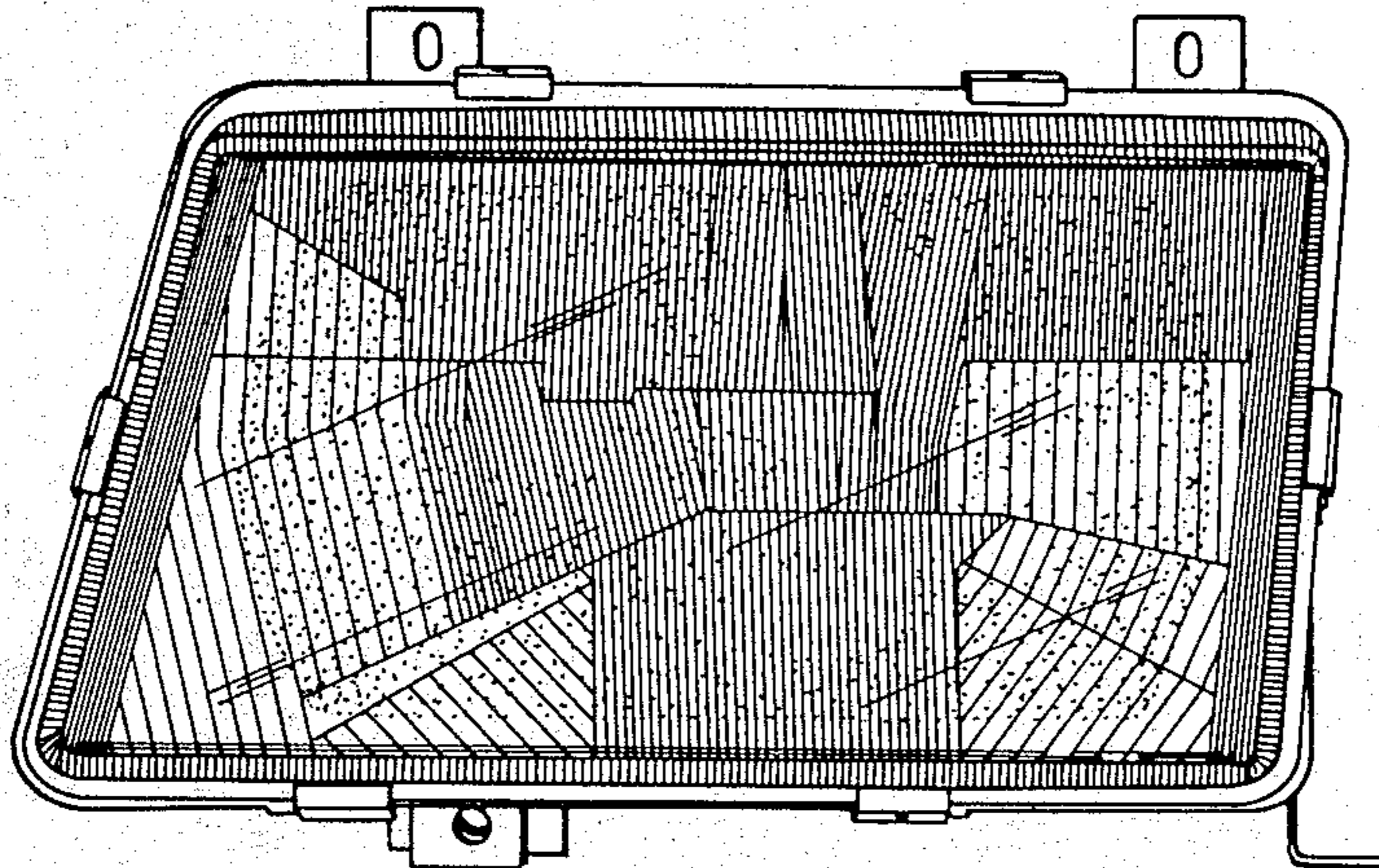

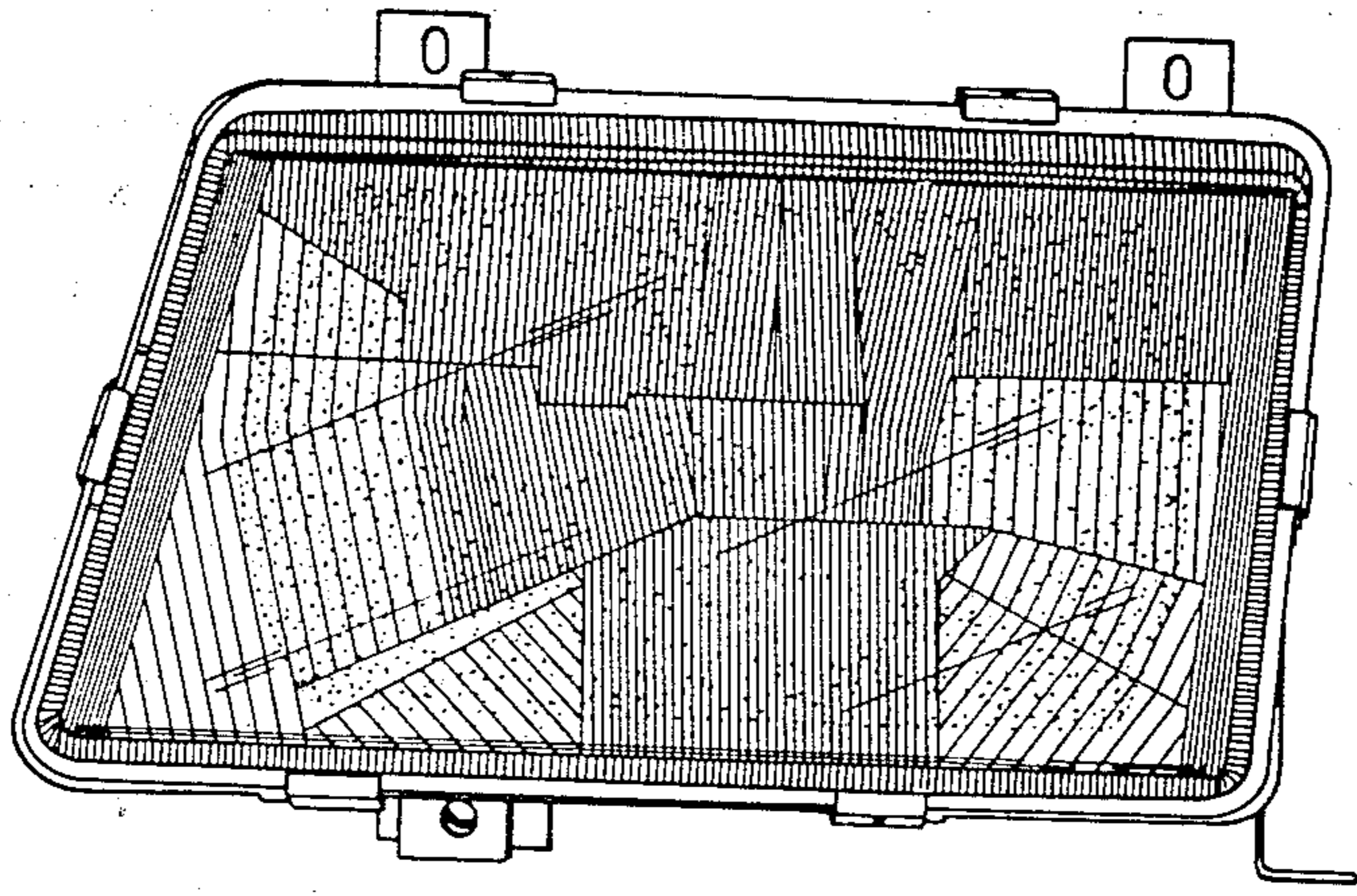

FIG. 1

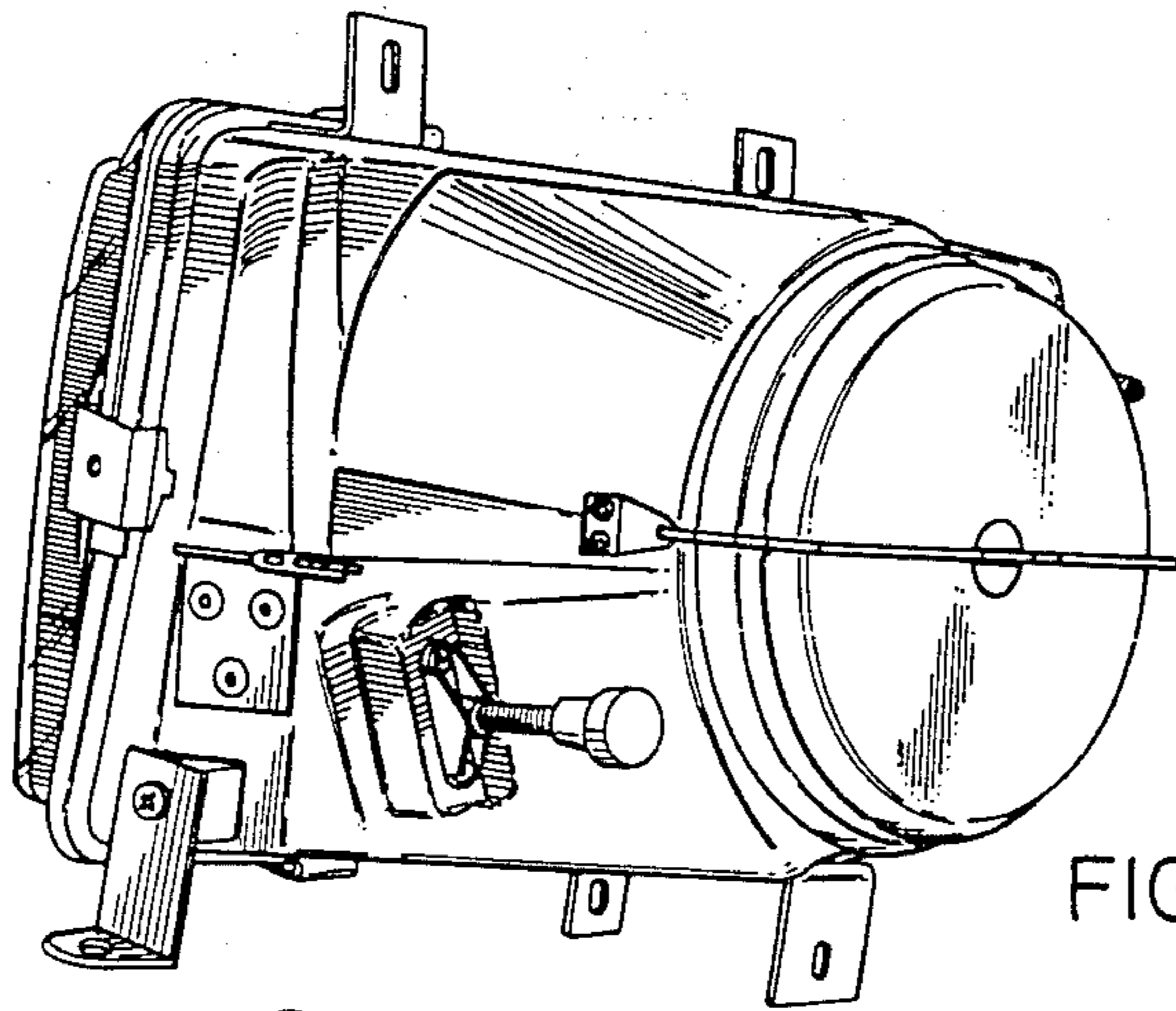

FIG. 2

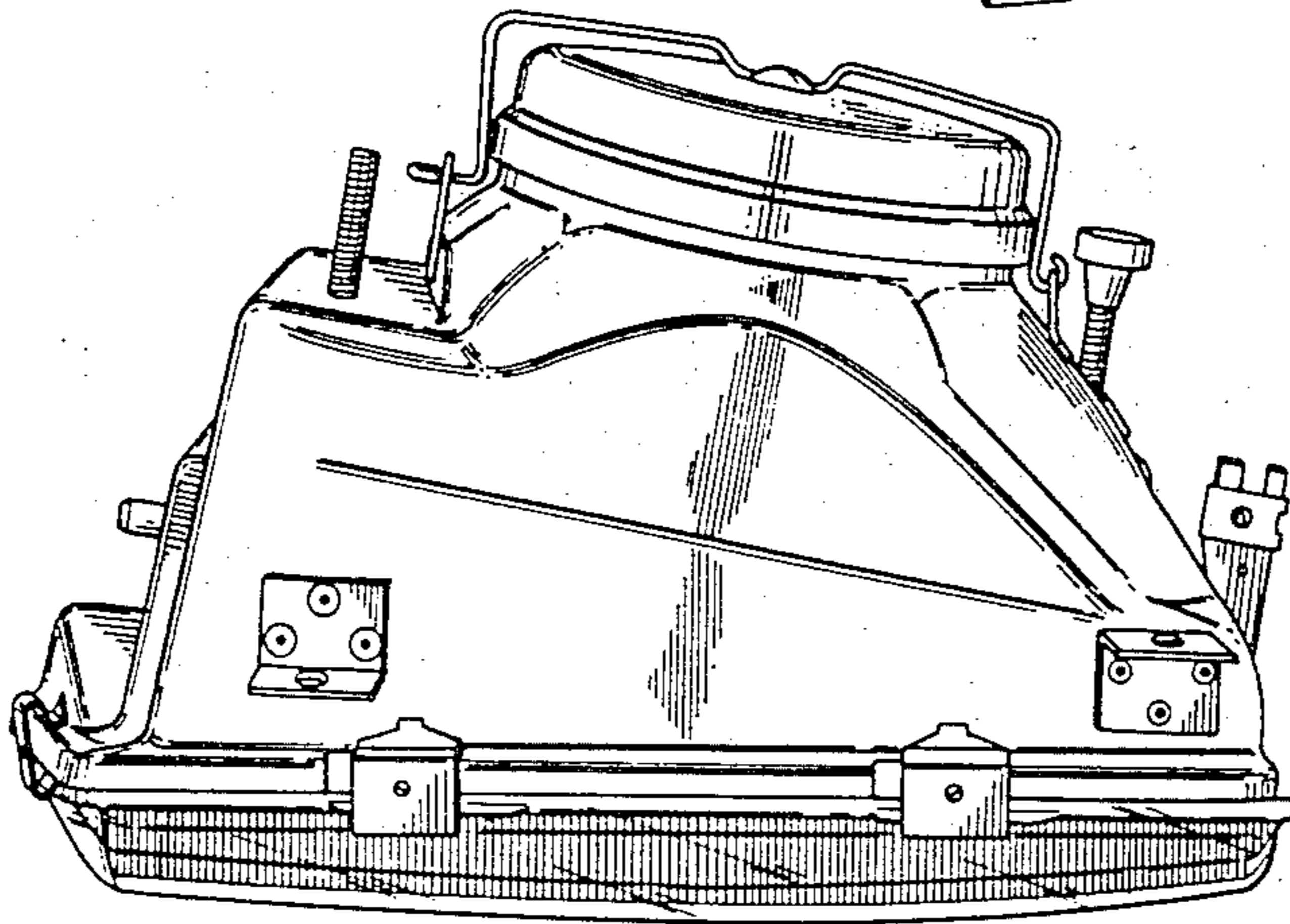

FIG. 3



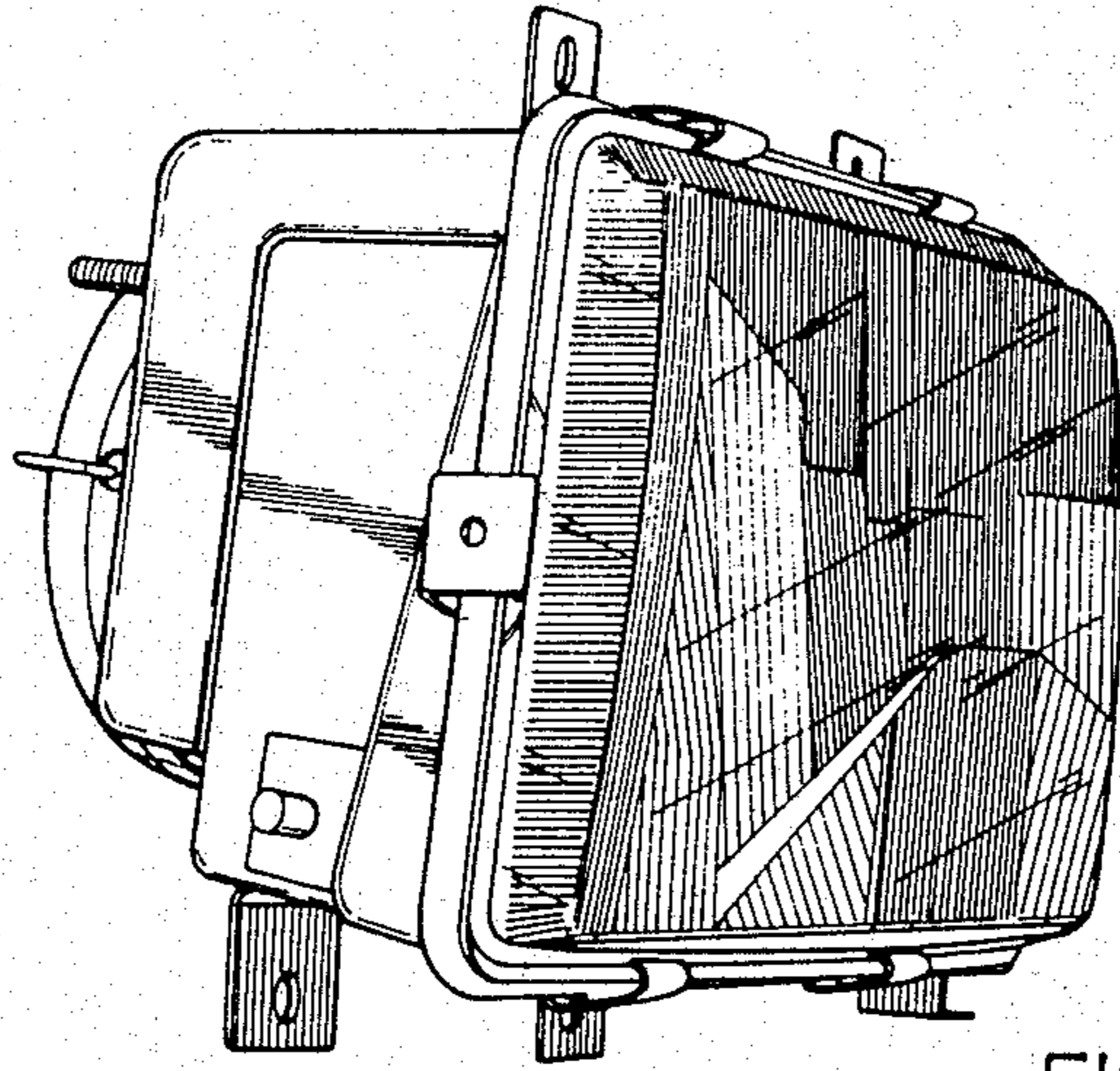

FIG. 4

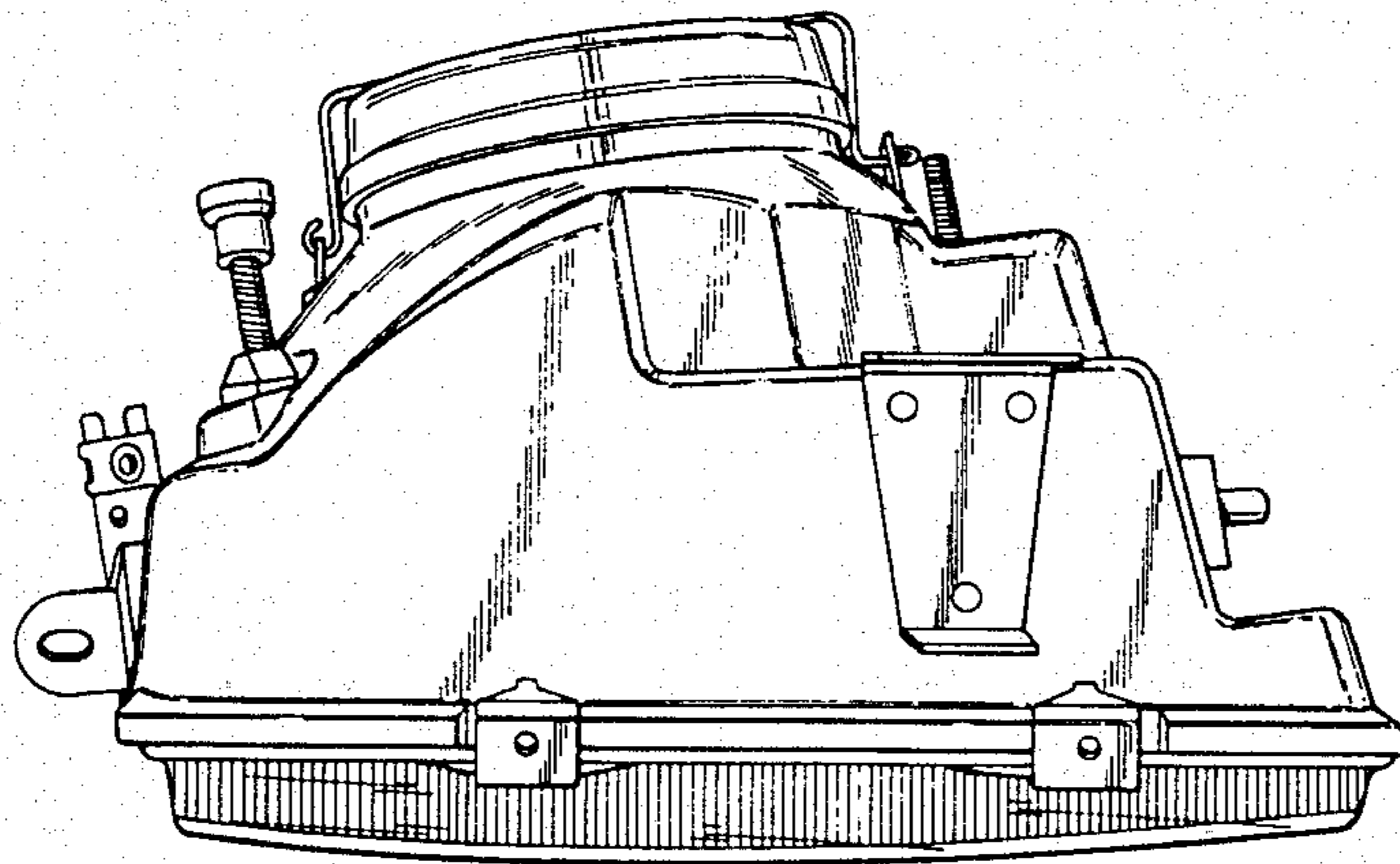

FIG. 5