

[54] **RIDING TOY VEHICLE**

3,907,331 9/1975 Lohr et al. 280/87.02

[76] **Inventor: Martin Blumenthal, 99 Longview Ave., Chatham, N.J. 07928**

[**] **Term: 14 Years**

[21] **Appl. No.: 533,401**

[22] **Filed: Sep. 19, 1983**

[52] **U.S. Cl. D21/76**

[58] **Field of Search D21/76, 78, 79, 80, D21/81, 128, 131, 132, 133, 134, 135, 136, 137, 139, 140; 280/87.01, 87.02 R, 87.1, 87.2; D12/110; 446/440, 451, 465, 466**

[56] **References Cited**

U.S. PATENT DOCUMENTS

- D. 272,166 1/1984 Orenstein D21/78
- D. 276,251 11/1984 Walkimura D21/134

OTHER PUBLICATIONS

Broncoo Flier, 1970, "T/X-ID" Cycle.

Primary Examiner—Charles A. Rademaker
Attorney, Agent, or Firm—George E. Kersey

[57] **CLAIM**

The ornamental design for a riding toy vehicle, as shown and described.

DESCRIPTION

FIG. 1 is a front perspective view of a riding toy vehicle showing my new design;
 FIG. 2 is a front elevational view thereof;
 FIG. 3 is a side elevational view thereof, the side opposite being substantially a mirror image;
 FIG. 4 is a rear elevational view thereof; and
 FIG. 5 is a bottom plan view thereof.

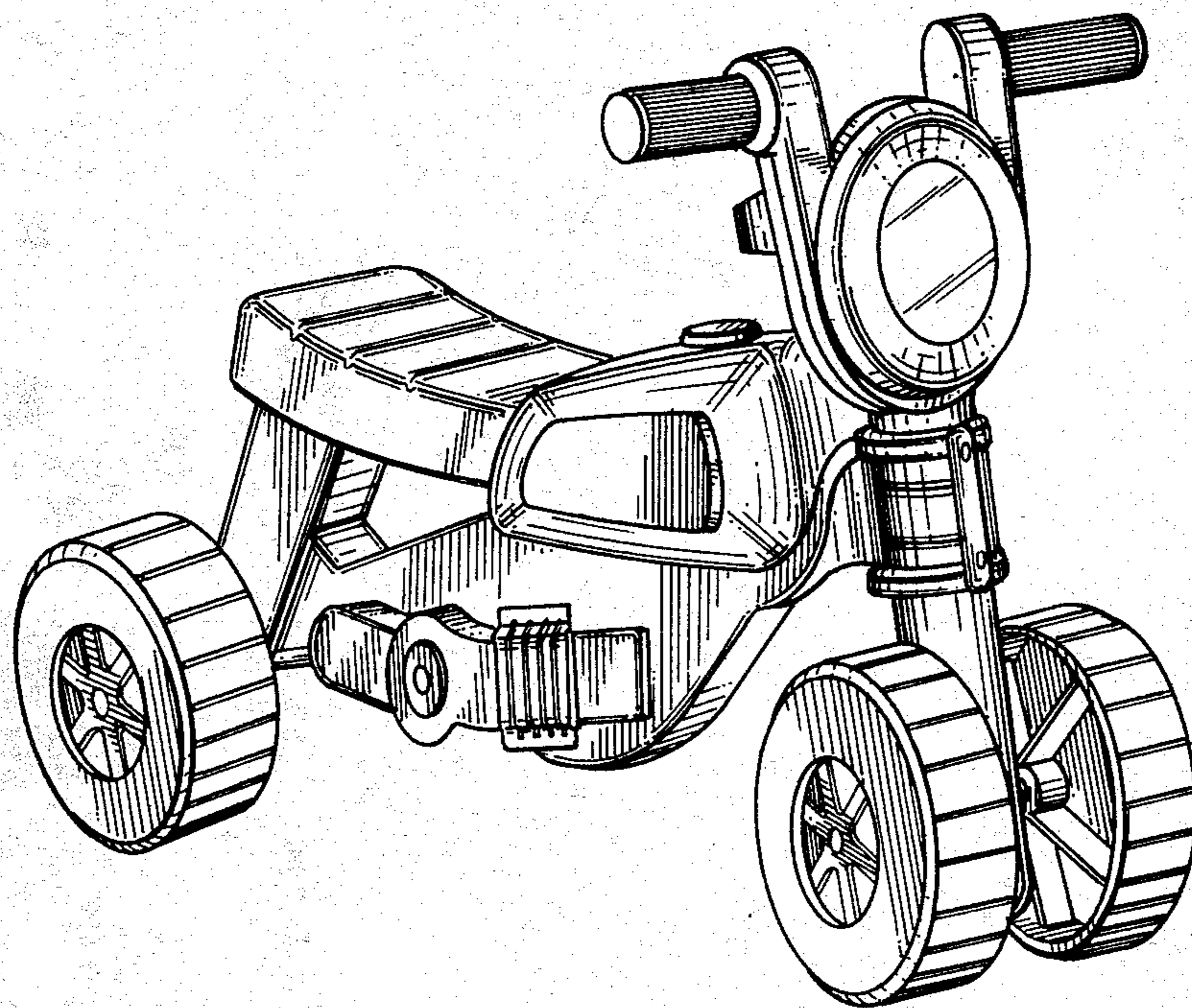
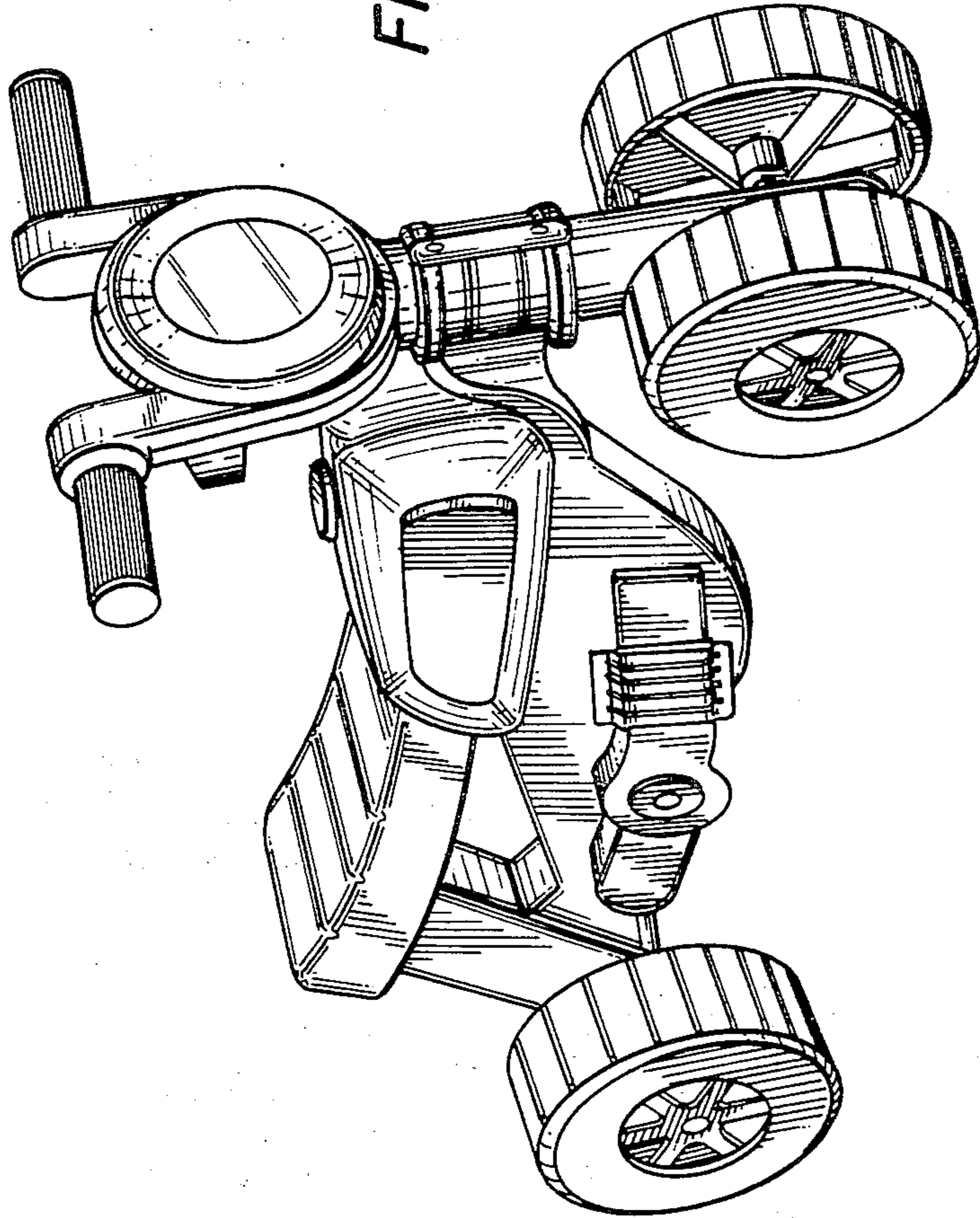

FIG. 1



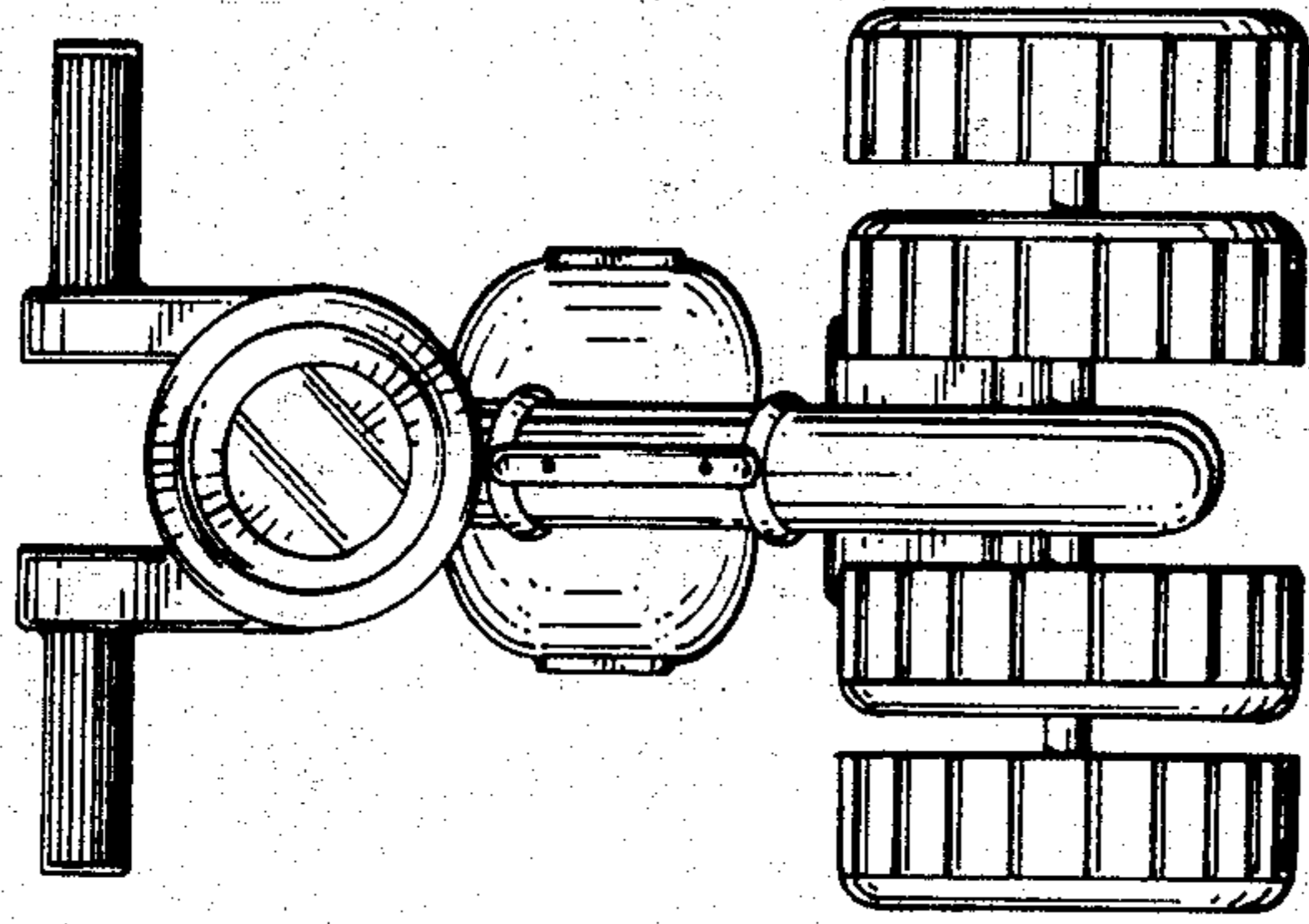

FIG. 2

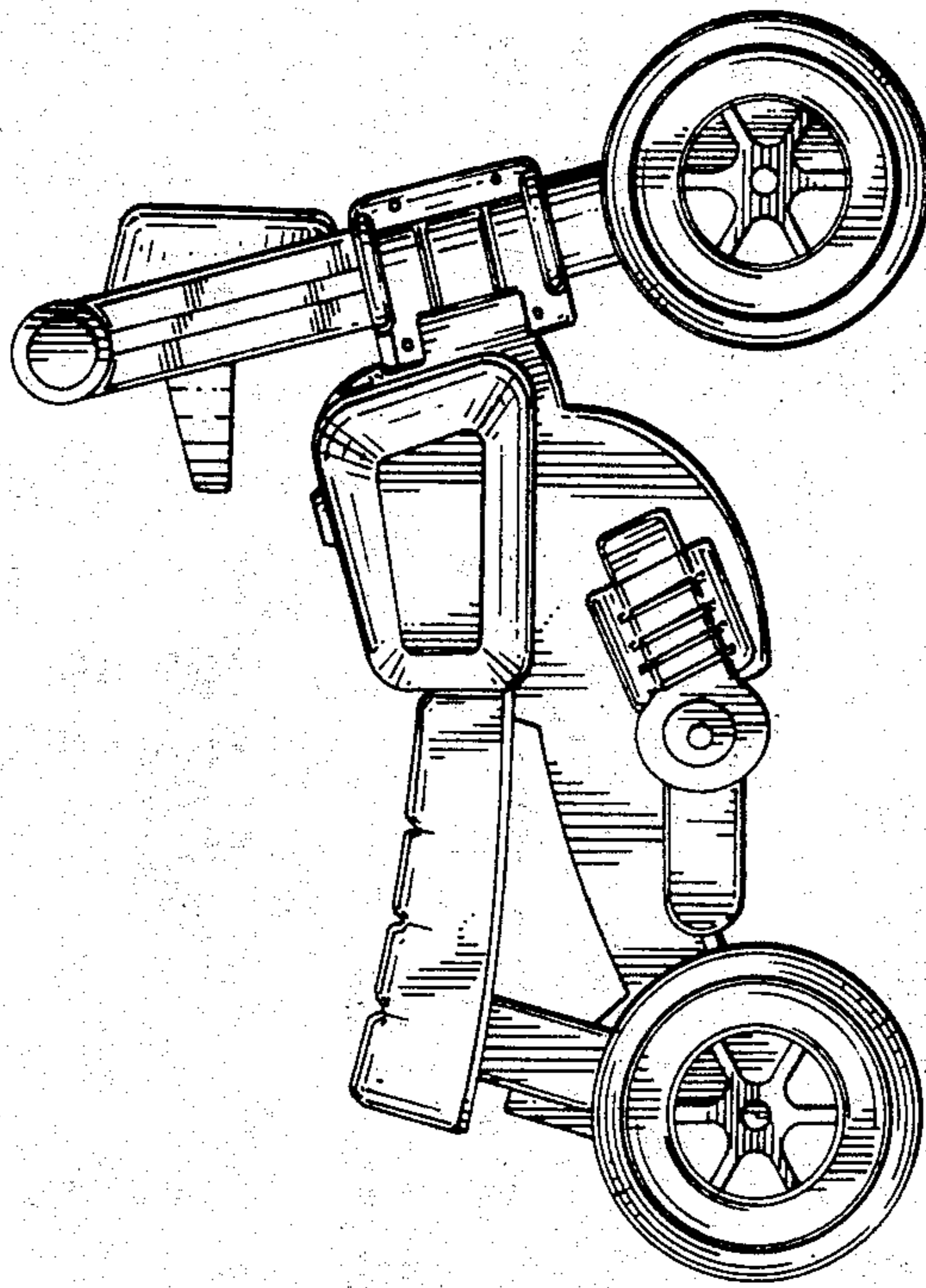

FIG. 3

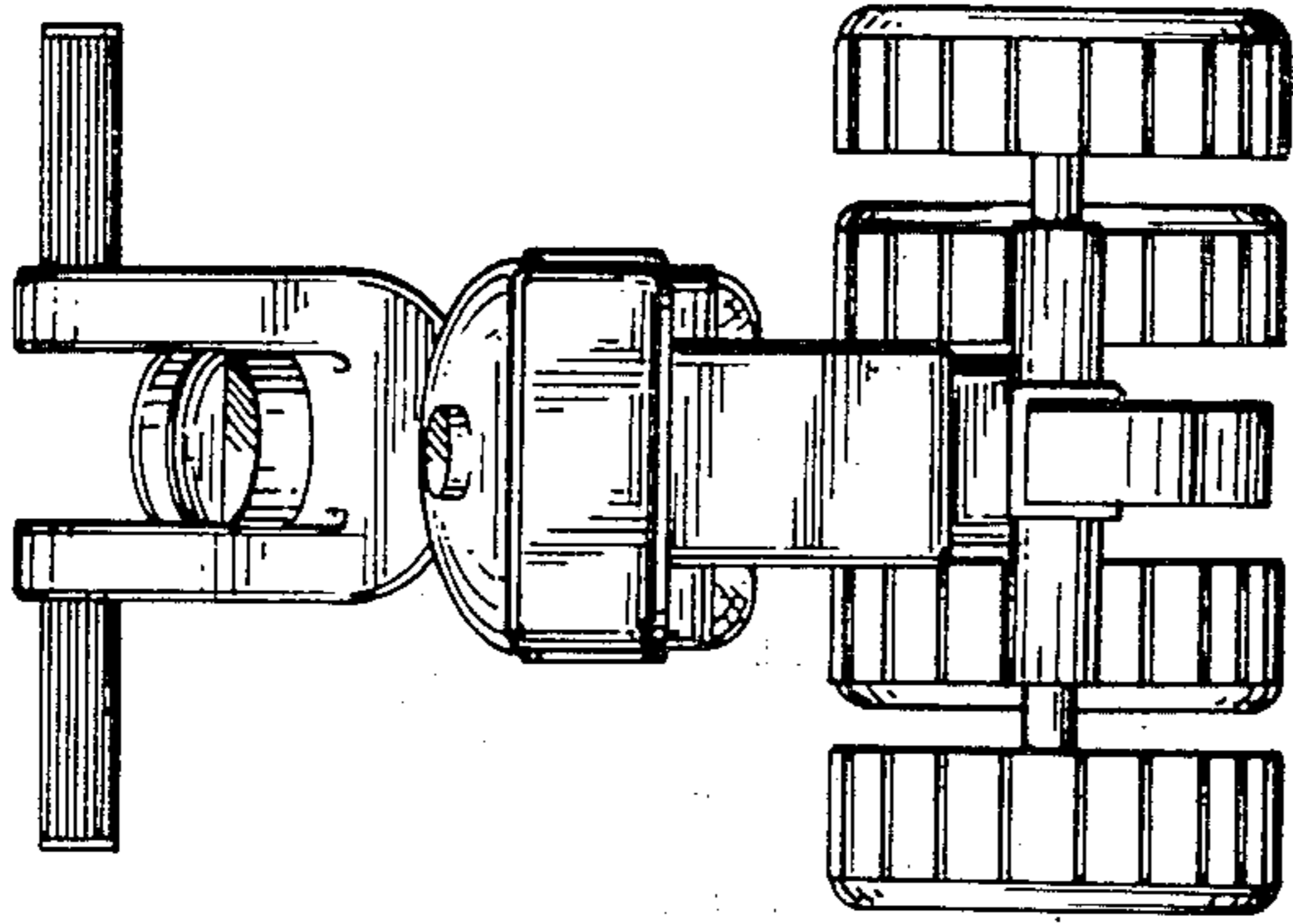

FIG. 4

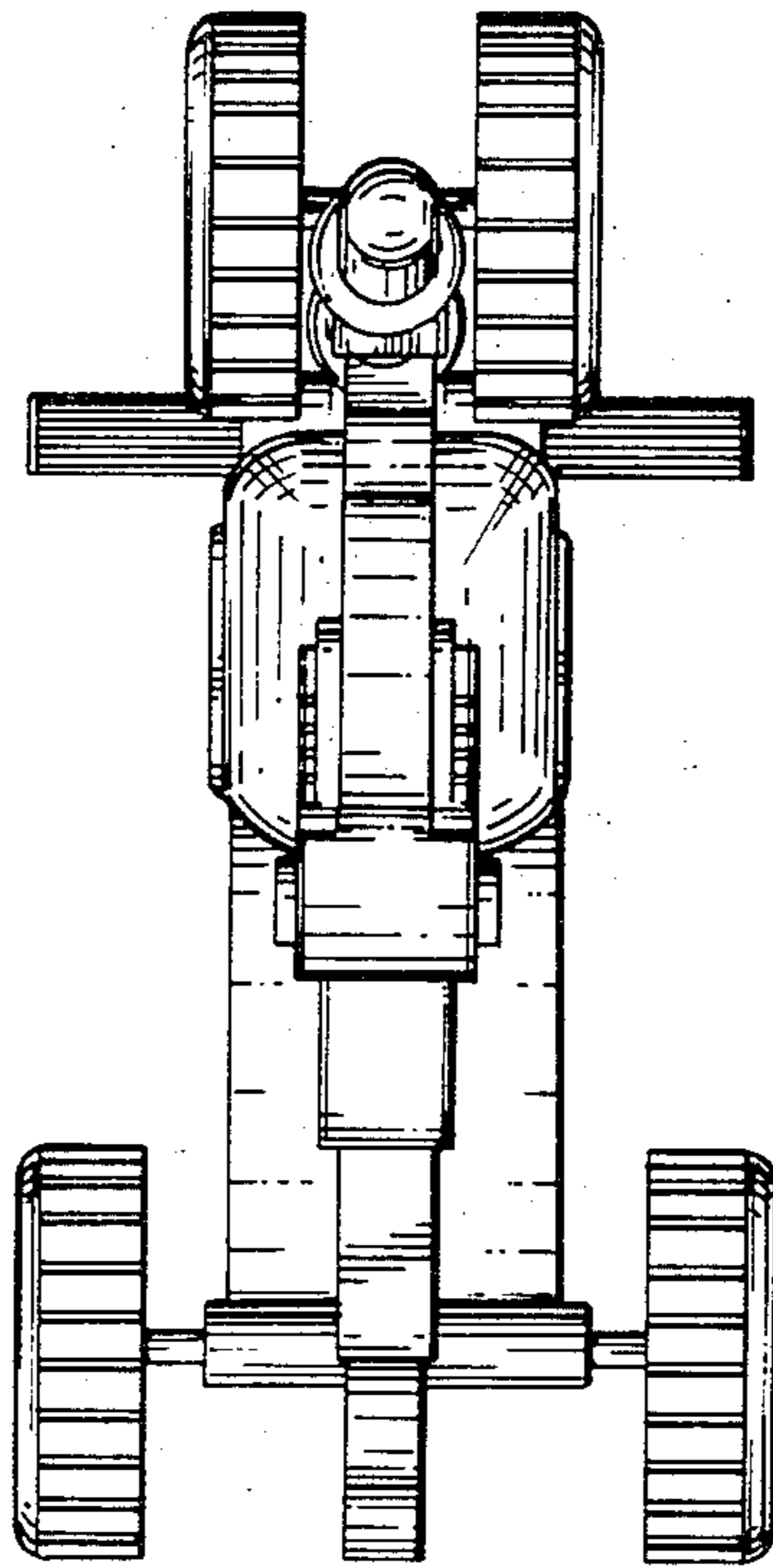

FIG. 5