

[54] **COMBINED VEHICLE DASHBOARD AND CONSOLE UNIT**

[75] **Inventors: Claüs Luthe, Munich; Hans Braun, Lohhof, both of Fed. Rep. of Germany**

[73] **Assignee: Bayerische Motoren Werke Aktiengesellschaft, Munich, Fed. Rep. of Germany**

[**] **Term: 14 Years**

[21] **Appl. No.: 478,509**

[22] **Filed: Mar. 24, 1983**

[30] **Foreign Application Priority Data**

Sep. 24, 1982 [DE] Fed. Rep. of Germany ... MR 13094

[52] **U.S. Cl. D12/192**

[58] **Field of Search D12/192; 180/90**

[56] **References Cited**

U.S. PATENT DOCUMENTS

D. 270,825 10/1983 Luthe et al. D12/192

OTHER PUBLICATIONS

Motor Trend, 2/80, P80, Dashboard & Console of BMW 320i, bottom left side of page.

Primary Examiner—James M. Gandy
Attorney, Agent, or Firm—Craig & Burns

[57] **CLAIM**

The ornamental design for a combined vehicle dashboard and console unit, as shown and described.

DESCRIPTION

FIG. 1 is a perspective view of the combined vehicle dashboard and console unit embodying our novel design from the left front and above;

FIG. 2 is a left side elevation view thereof;

FIG. 3 is a right side elevation view thereof;

FIG. 4 is a top plan view thereof;

FIG. 5 is a bottom plan view thereof;

FIG. 6 is a front elevation view thereof; and

FIG. 7 is a rear elevation view thereof.

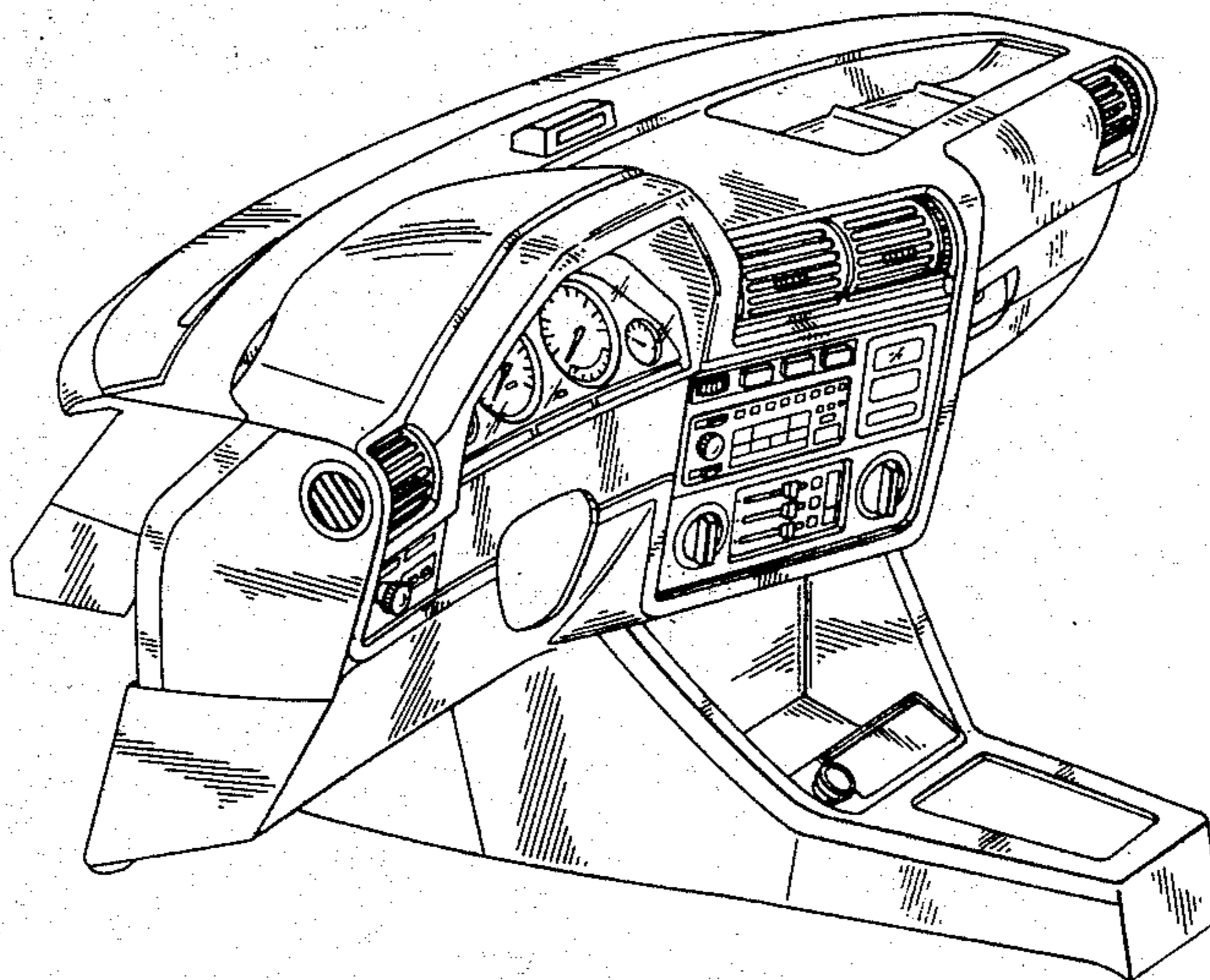

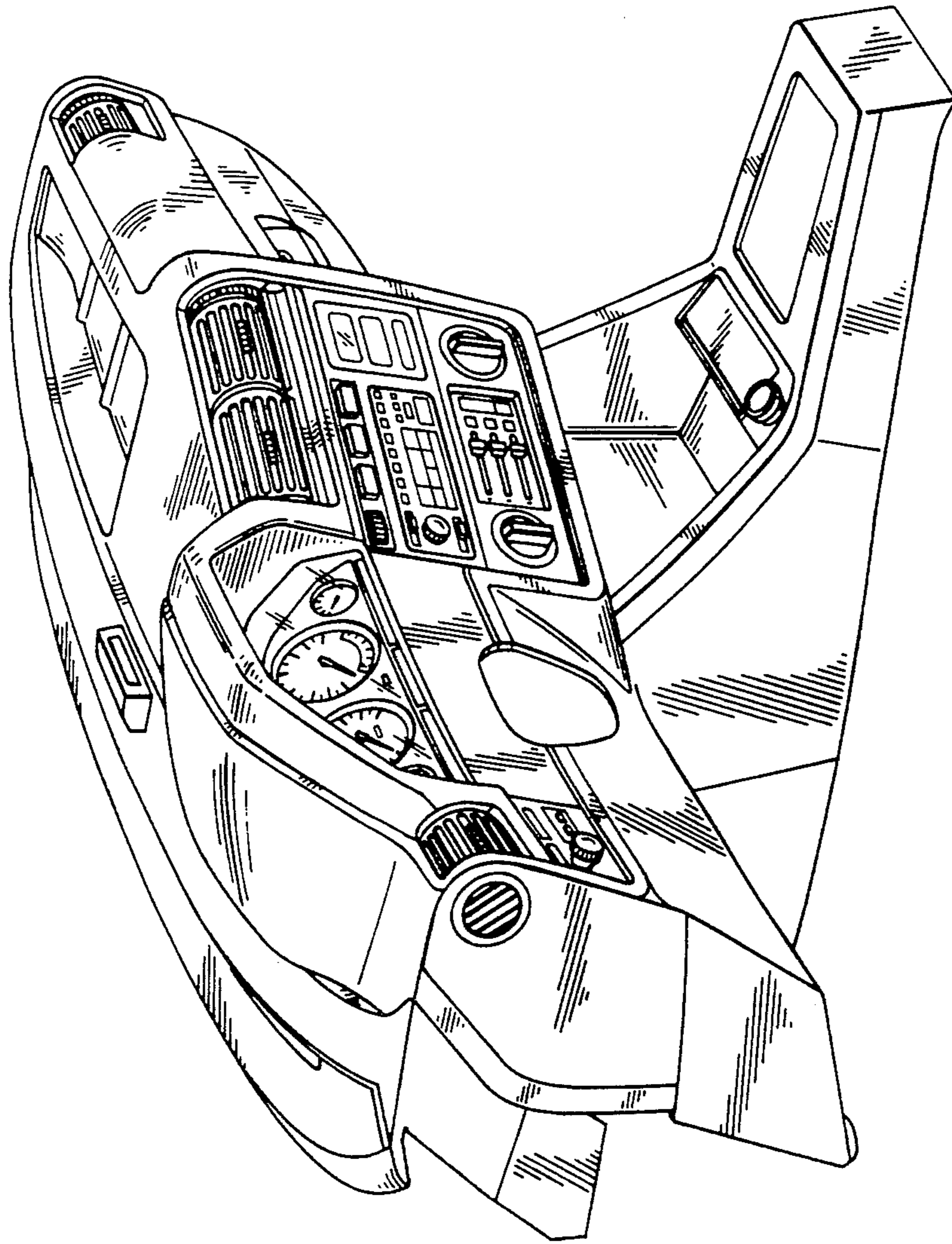
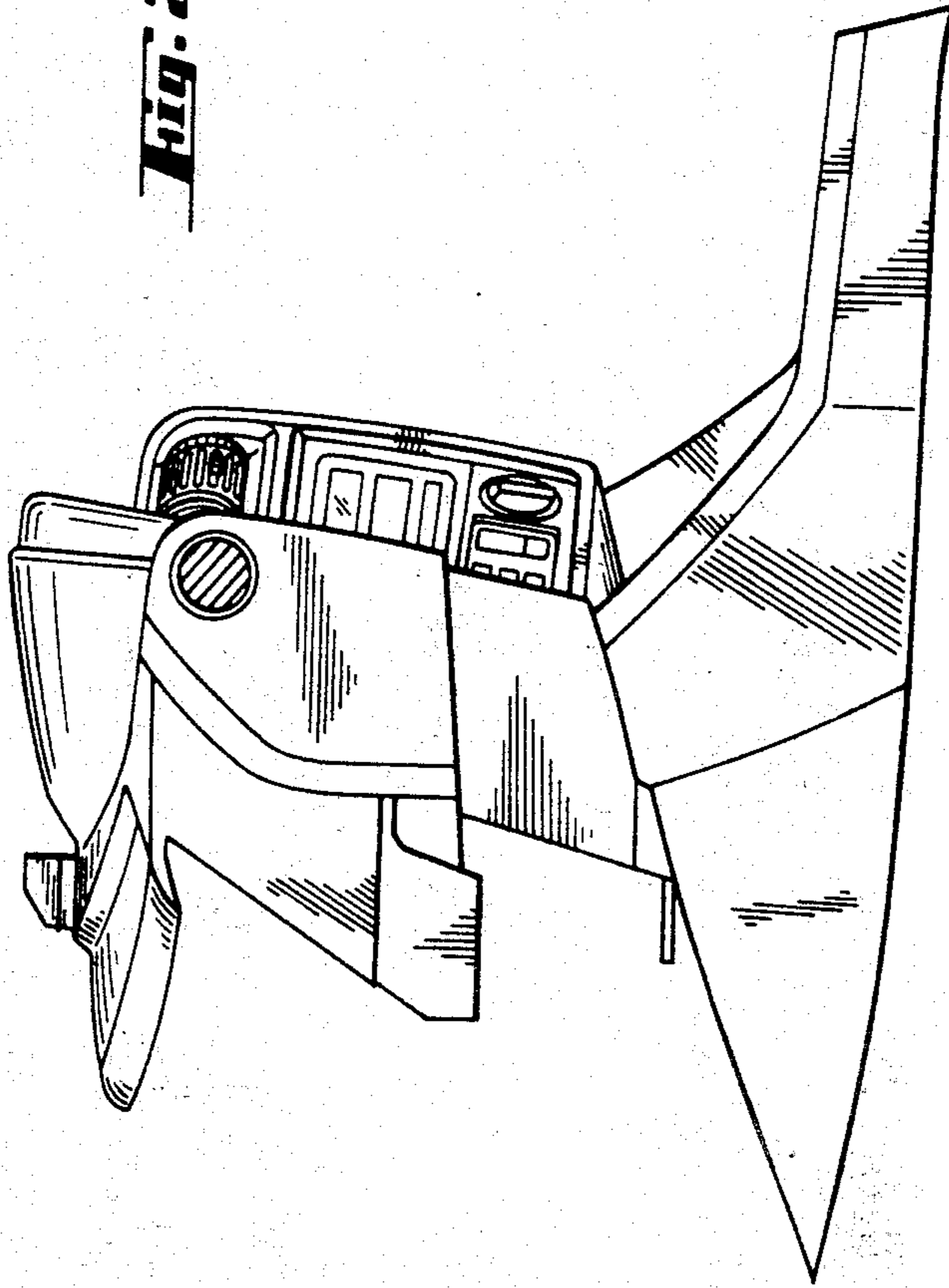

Fig. 1

Fig. 2



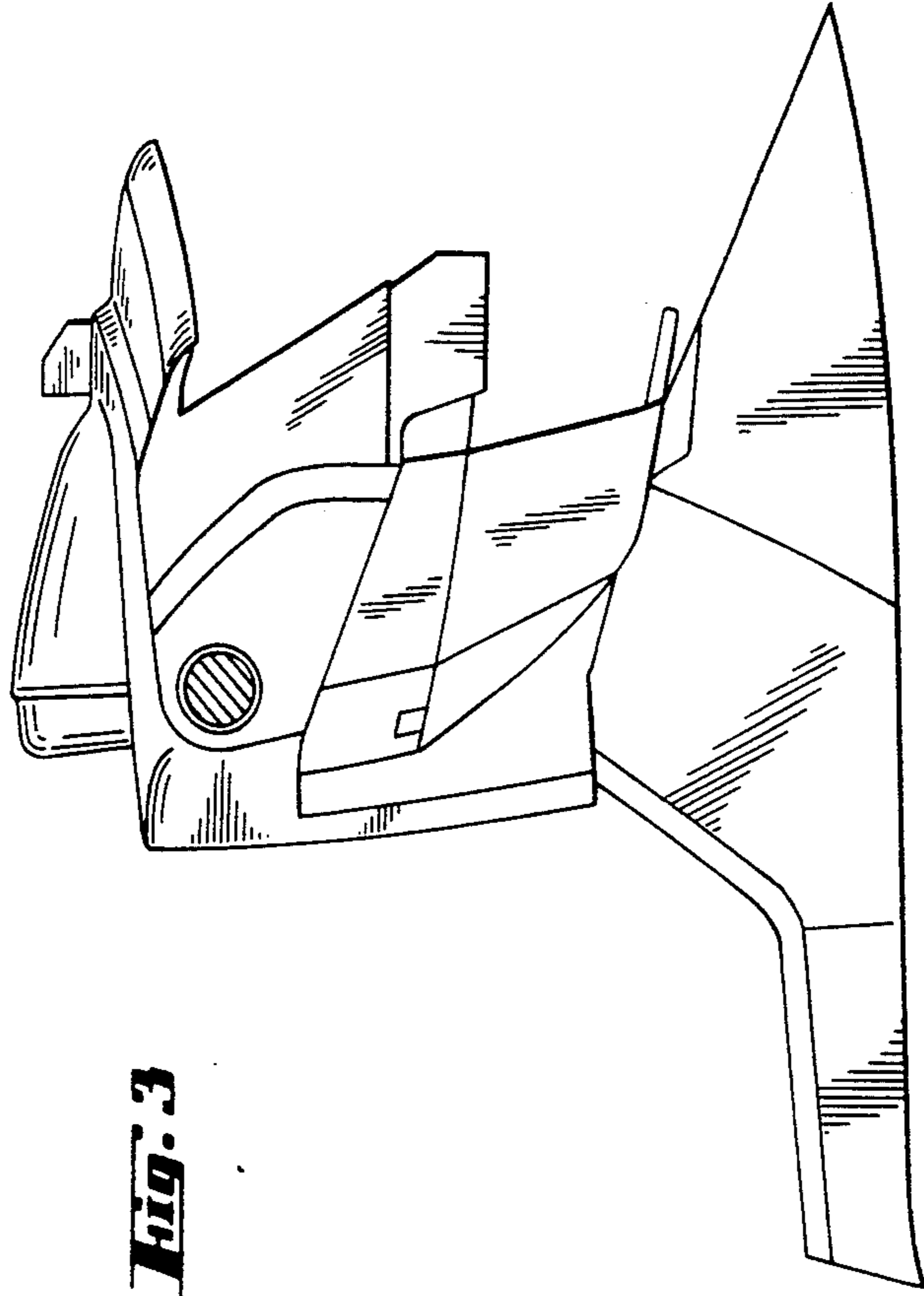
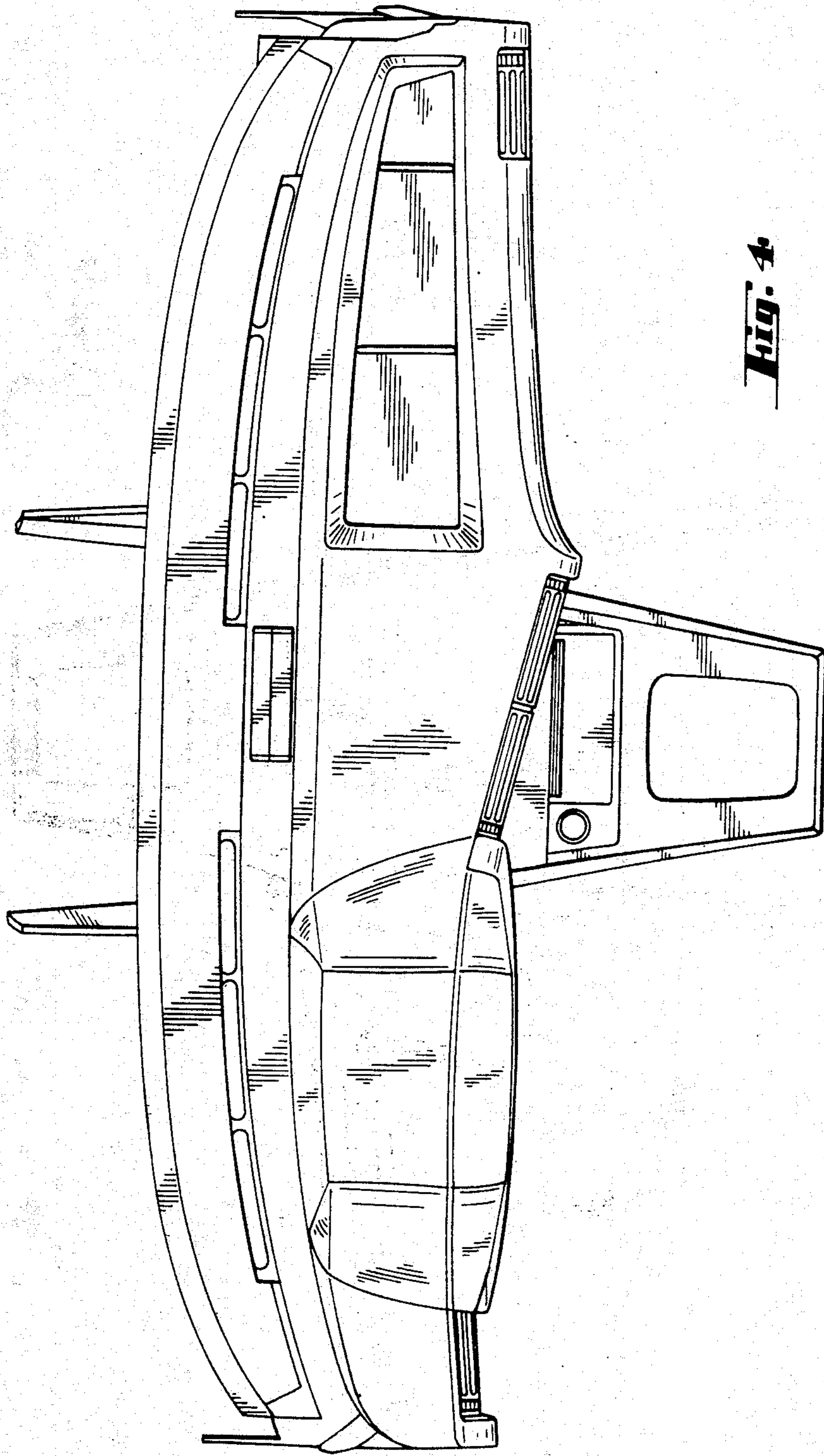

Fig. 3



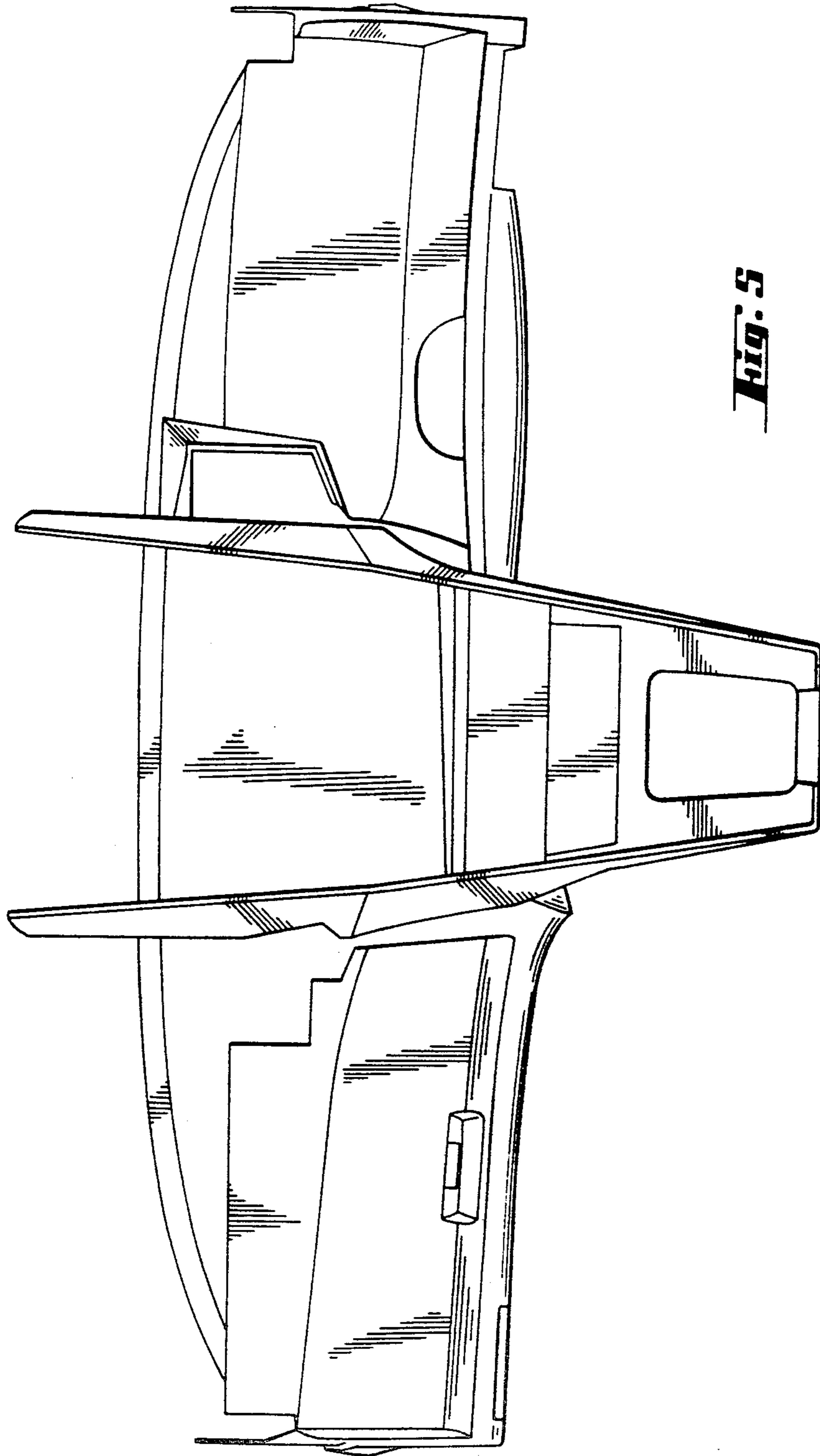

Fig. 5

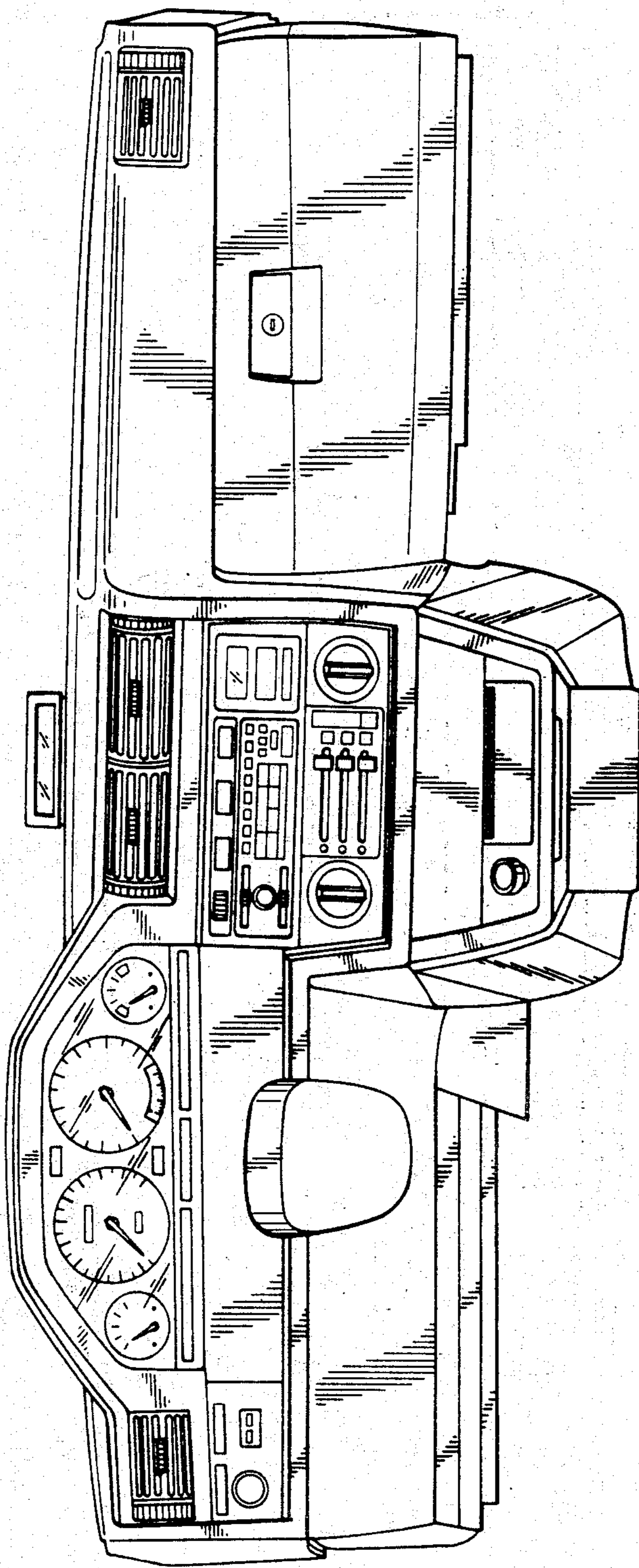

Fig. 6

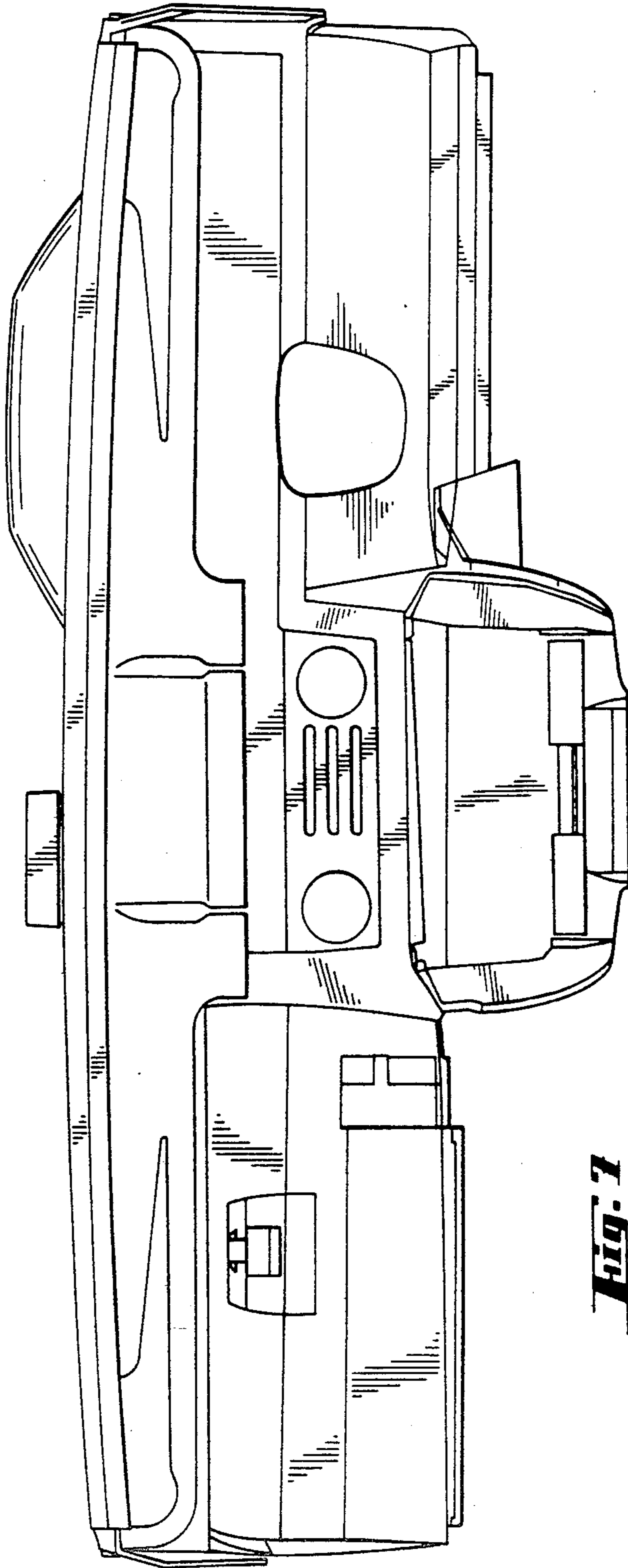

Fig. 7