

[54] **OPEN SPORT CAR**

[75] **Inventors: Wolfgang Möebius, Stuttgart; Peter Reisinger, Ditzingen, both of Fed. Rep. of Germany**

[73] **Assignee: Porsche AG, Fed. Rep. of Germany**

[**] **Term: 14 Years**

[21] **Appl. No.: 497,273**

[22] **Filed: May 23, 1983**

[30] **Foreign Application Priority Data**

Dec. 27, 1982 [DE] Fed. Rep. of Germany MR 5559
[52] **U.S. Cl. D12/92**
[58] **Field of Search D12/91, 92; 296/185**

[56] **References Cited
PUBLICATIONS**

Road & Track, 5/82, P 154, 1973 Porsche 911T Tarea, center right side of page.
Motor Trend, 10/81, p. 94, Porsche, C 928.
Road and Track, 11/82, p. 124, Maserati 450 S, lower center of page.
Motor Trend, 2/82, p. 98, Porsche, upper left side of page.

Primary Examiner—James M. Gandy
Attorney, Agent, or Firm—Barnes & Thornburg

[57] **CLAIM**

The ornamental design for an open sport car, as shown.

DESCRIPTION

FIG. 1 is a left, front perspective view of an open sport car showing our new design;
FIG. 2 is a right, front perspective view thereof from above;
FIG. 3 is a left rear perspective view thereof from above; and
FIG. 4 is a left side elevation view thereof.

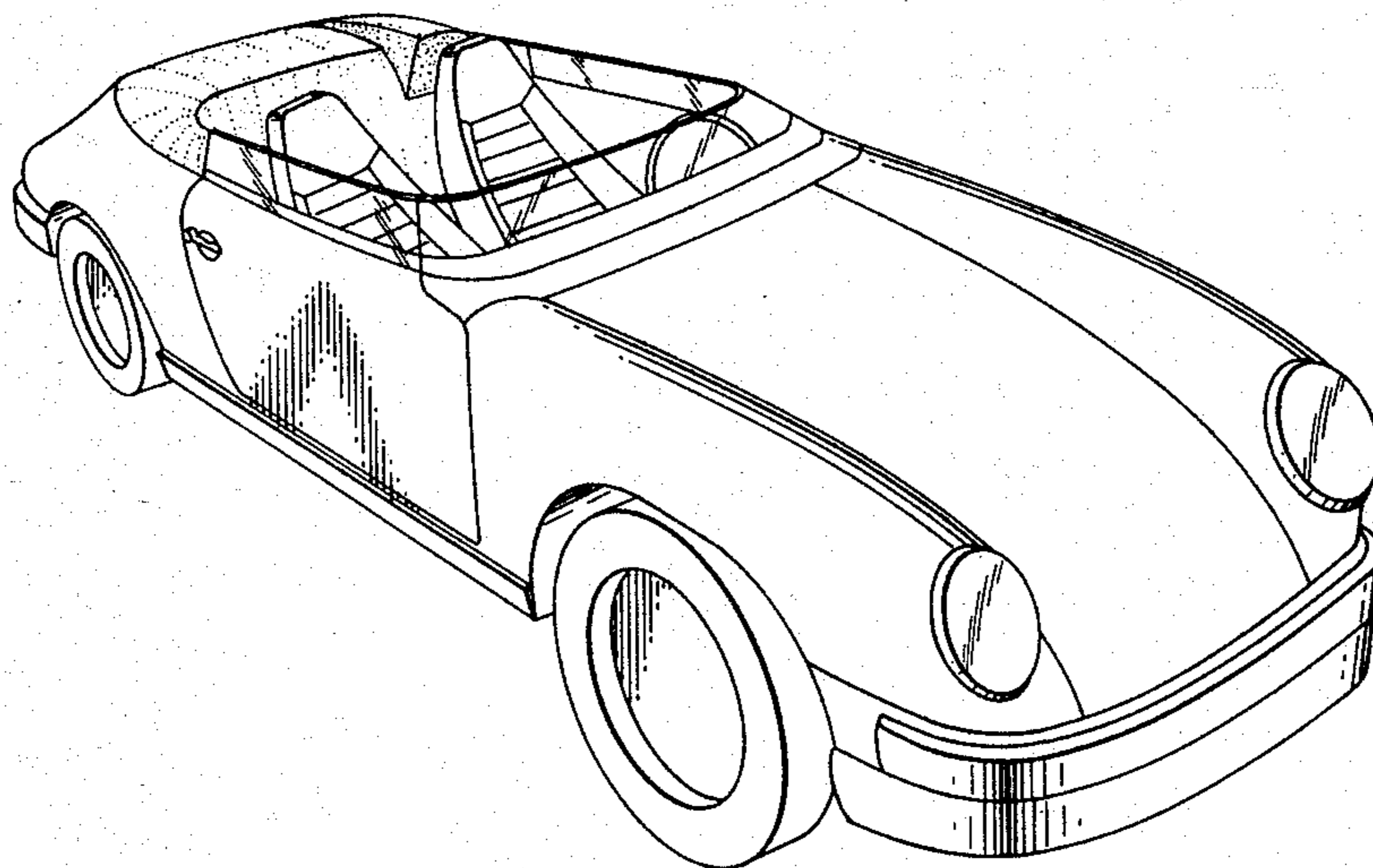

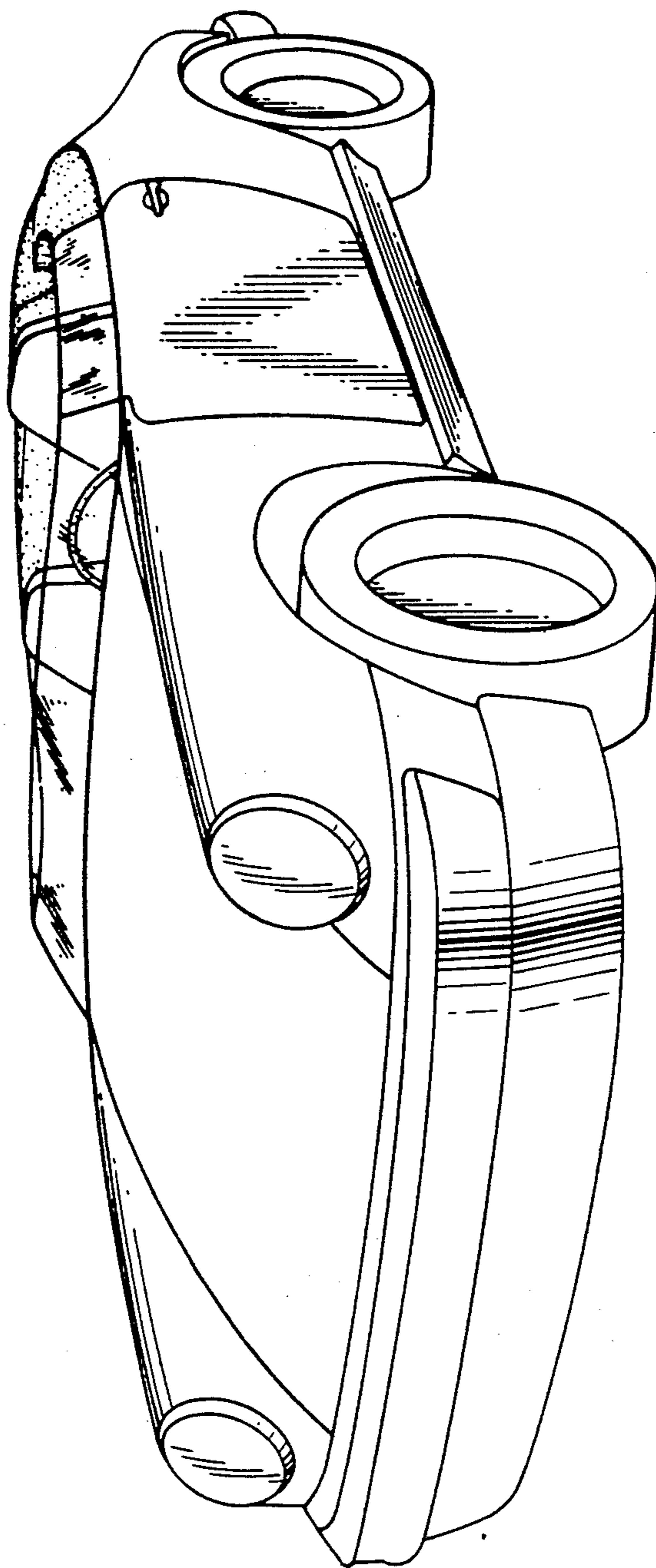
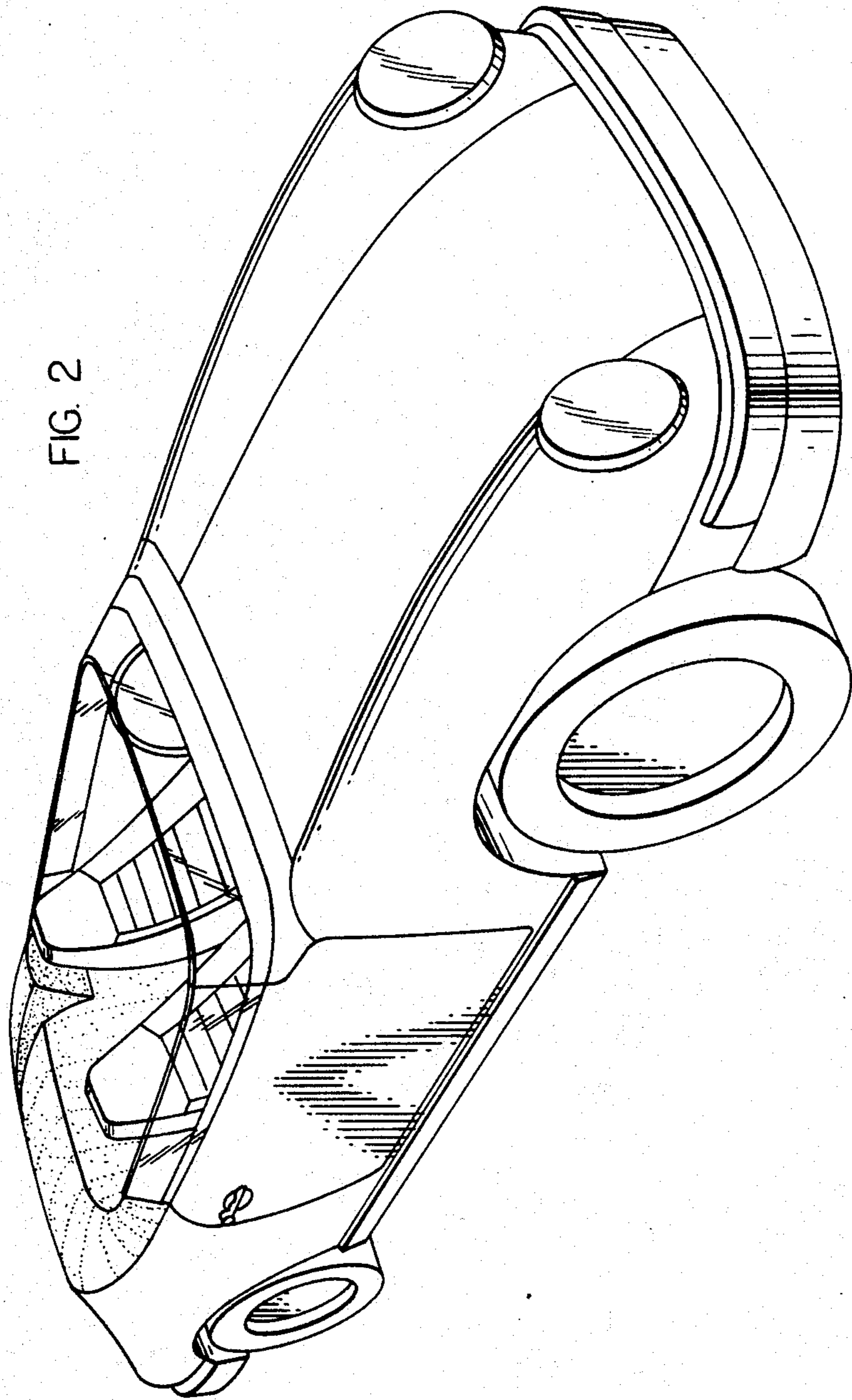

FIG. 1

FIG. 2



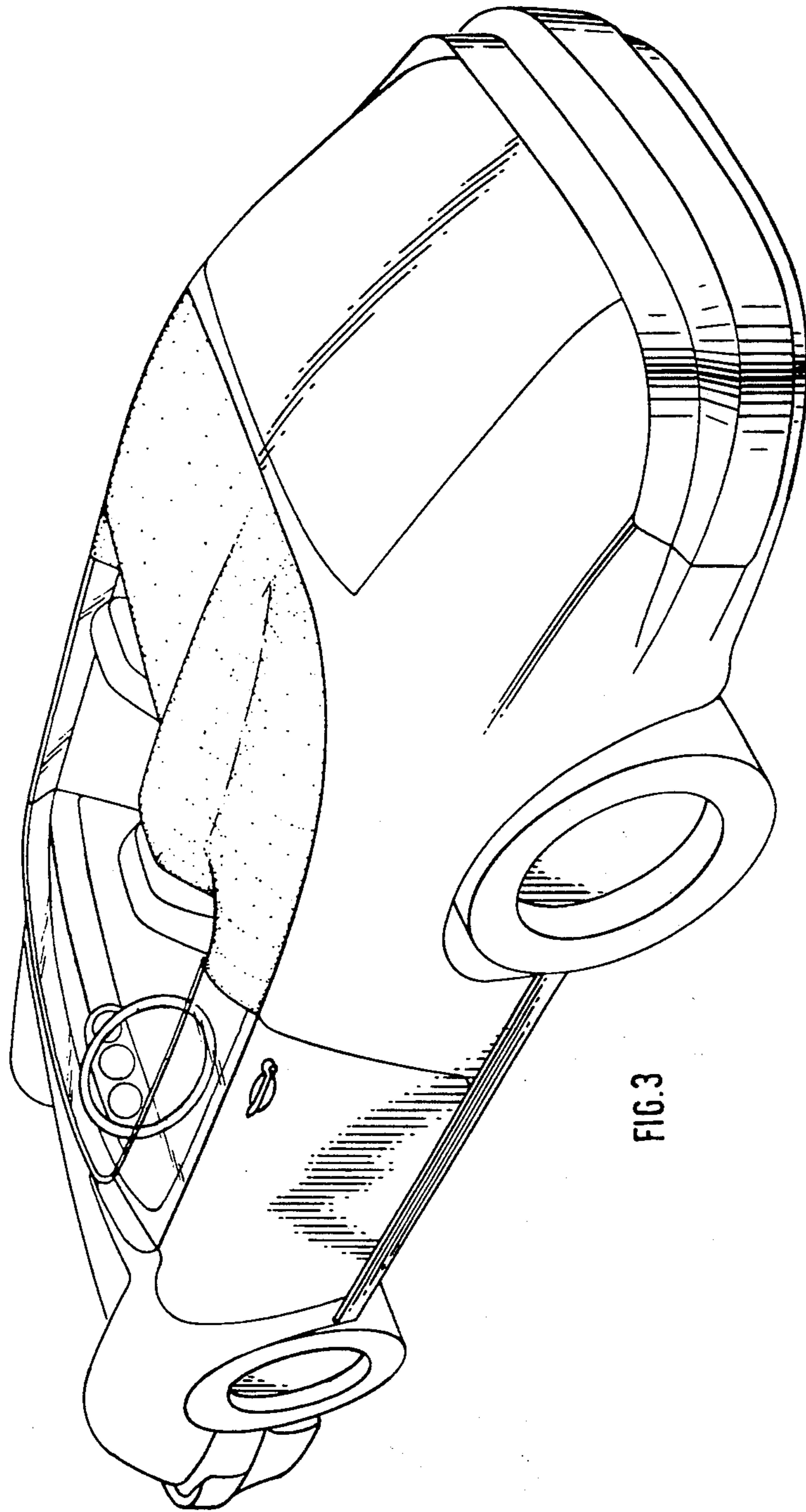

FIG. 3

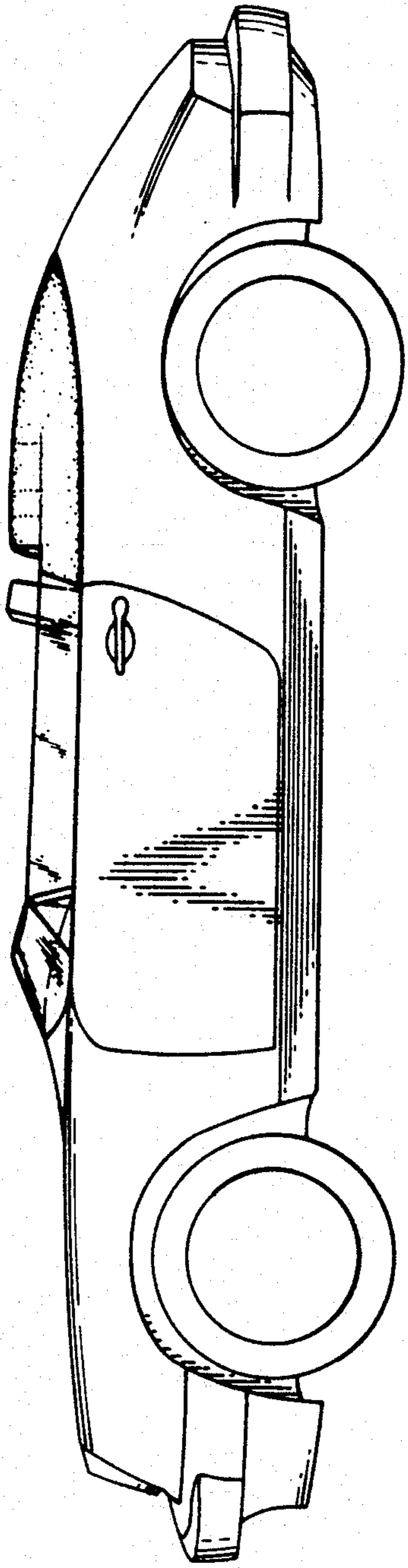

FIG. 4