

[54] **VEHICLE TIRE**

[75] **Inventors: Toshio Igarashi, Tokyo; Hideaki Nishio, Saitama, both of Japan**

[73] **Assignee: Bridgestone Tire Company Limited, Tokyo, Japan**

[**] **Term: 14 Years**

[21] **Appl. No.: 372,261**

[22] **Filed: Apr. 26, 1982**

[30] **Foreign Application Priority Data**

Oct. 27, 1981 [JP] Japan 56-47514

[52] **U.S. Cl. D12/151**

[58] **Field of Search D12/146-151; 152/209 R, 209 B, 209 D**

[56] **References Cited**

PUBLICATIONS

Firestone Off The Highway Tires & Tubes Catalog,

Rock Grip Excavator Tubeless Tire, center left side of page.

Primary Examiner—James M. Gandy
Attorney, Agent, or Firm—Sughrue, Mion, Zinn, Macpeak, and Seas

[57] **CLAIM**

The ornamental design for a vehicle tire, as shown and described.

DESCRIPTION

FIG. 1 is a perspective view of a vehicle tire showing our new design, it being understood that the tread pattern is repeated throughout the circumference of the tire;

FIG. 2 is an end elevational view thereof;

FIG. 3 is a side elevational view thereof, the opposite side being a mirror image thereof; and

FIG. 4 is a cross-sectional view thereof, taken about line IV—IV of FIG. 2.

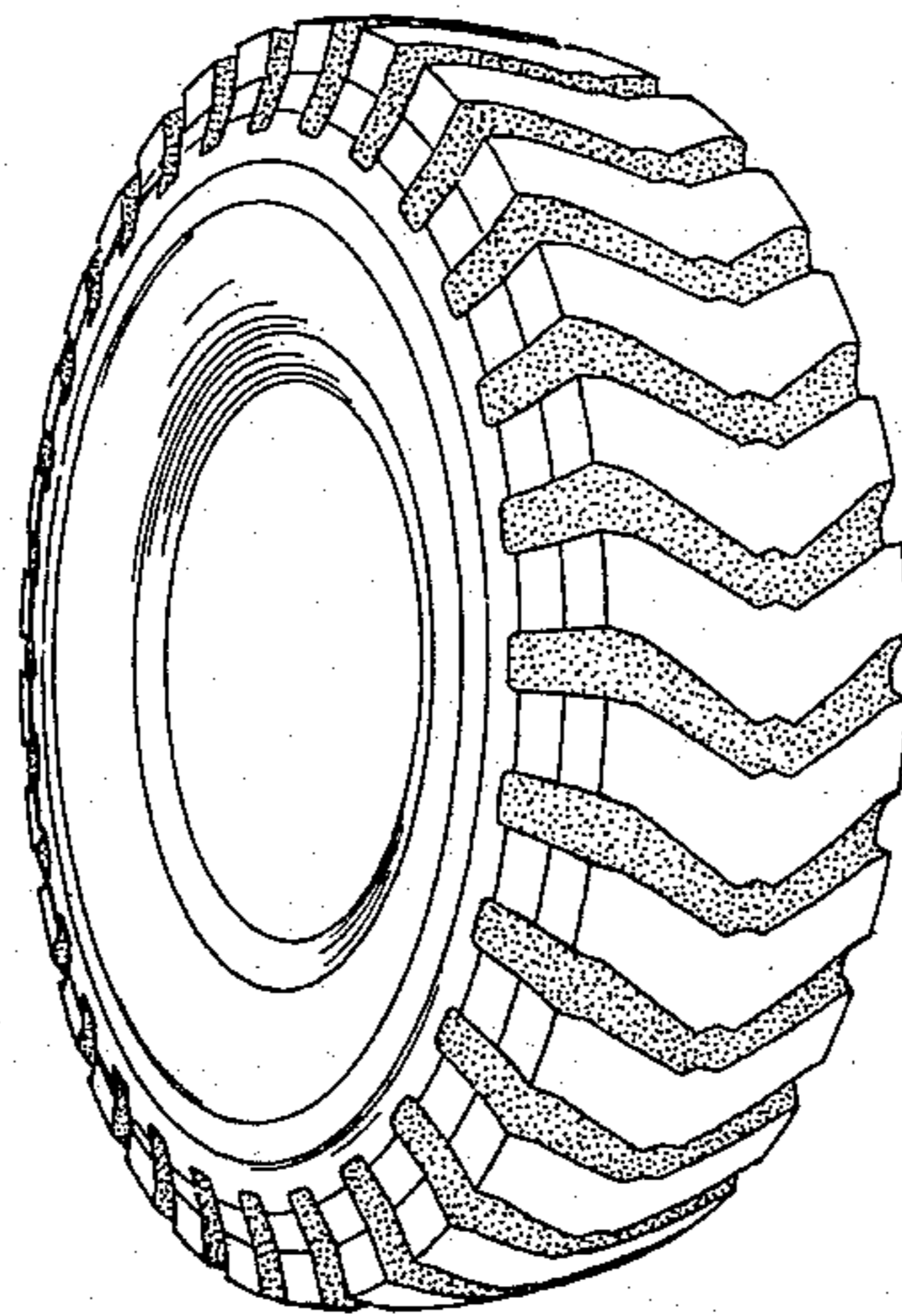

FIG. 2

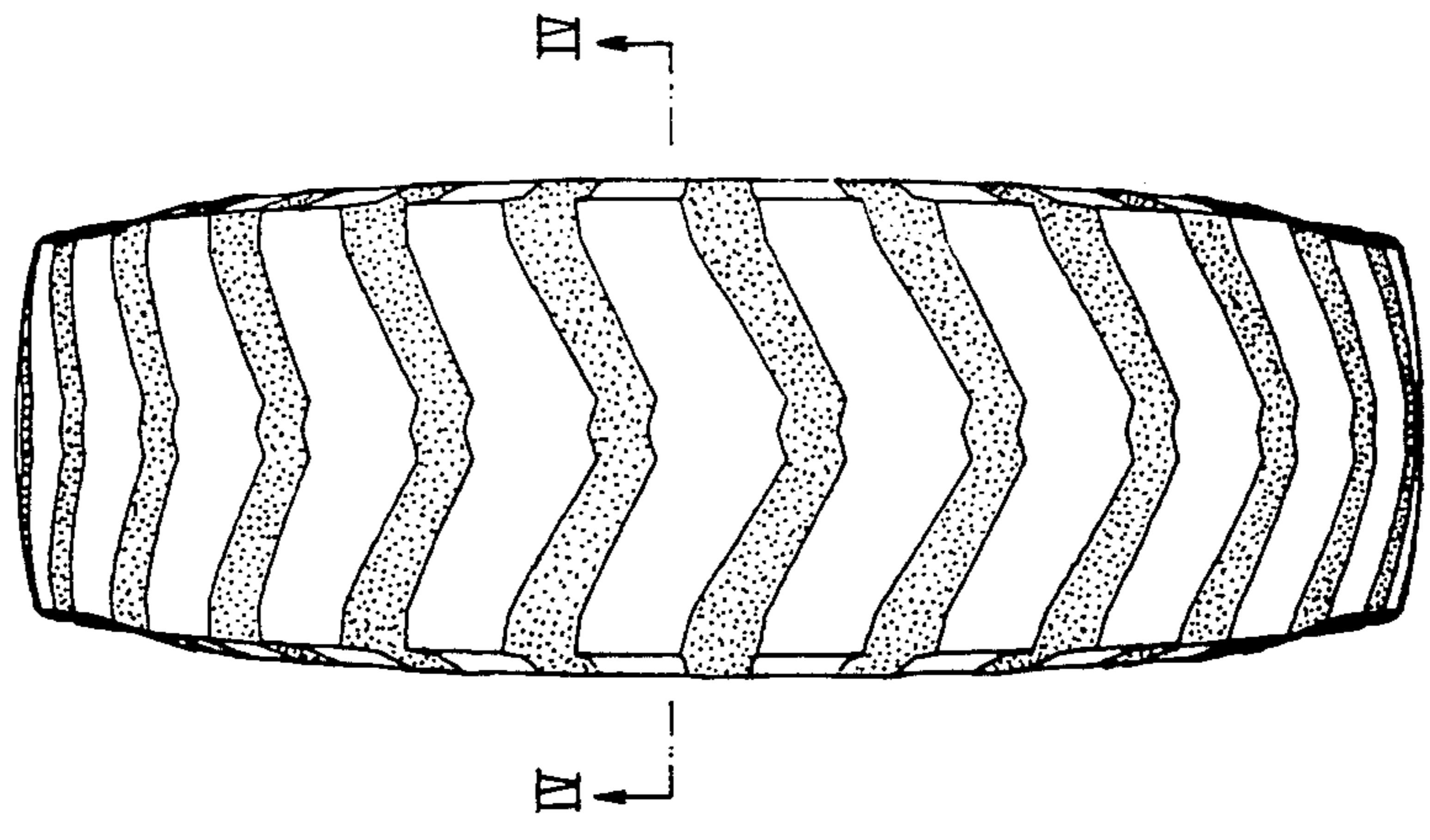

FIG. 1

