

[54] TELEPHONE SET WITH AUTOMATIC DIALER AND SPEAKER PHONE

[75] Inventors: Haruo Baba, Kanagawa; Teisuke Kurosu, Tokyo; Fumiharu Ohta, Kanagawa; Kazumasa Takenaka, Kanagawa; Satoshi Watanabe, Kanagawa, all of Japan

[73] Assignee: Matsushita Electric Industrial Co., Ltd., Osaka, Japan

[**] Term: 14 Years

[21] Appl. No.: 573,747

[22] Filed: Jan. 25, 1984

[30] Foreign Application Priority Data

Aug. 12, 1983 [JP] Japan 58-35622
[52] U.S. Cl. D14/52; D14/53; D14/63; D14/62; D14/58
[58] Field of Search D14/52, 53, 58, 63, D14/62, 64, 60; 179/179, 100 R, 100 D, 100 L, 100 C, 101, 103

[56] References Cited

U.S. PATENT DOCUMENTS

Table with 4 columns: Patent No., Date, Inventor, and Reference No. (e.g., D. 278,533 4/1985 Ando D14/58)

OTHER PUBLICATIONS

Toshiba EKTS Booklet published 9-1979; Sunday EKTS Models.

B. A. Pargh Company, Inc. Catalog ©1983: Panasonic Models VA 8020-8030 at p. 37.

Primary Examiner—James R. Largen
Assistant Examiner—Horace B. Fay
Attorney, Agent, or Firm—Sughrue, Mion, Zinn, Macpeak, and Seas

[57] CLAIM

The ornamental design for a telephone set with automatic dialer and speaker phone, as shown and described.

DESCRIPTION

FIG. 1 is a front, top and right side perspective view of a telephone set with automatic dialer and speaker phone showing our new design;
FIG. 2 is a rear, top, and left side perspective view thereof;
FIG. 3 is a front, bottom and left side perspective view thereof;
FIG. 4 is a rear, bottom and right side perspective view thereof;
FIG. 5 is a front, top and right side perspective view thereof with the hand set displaced therefrom;
FIG. 6 is a top, rear and right side perspective view of the hand set forming an element thereof; and
FIG. 7 is a front, bottom and left side perspective view of the hand set thereof.
The handset is shown independently of the claimed set in FIGS. 6 and 7 for ease and clarity of representation, and the coiled line is shown in truncated form to indicate indeterminate length, and for ease of illustration.

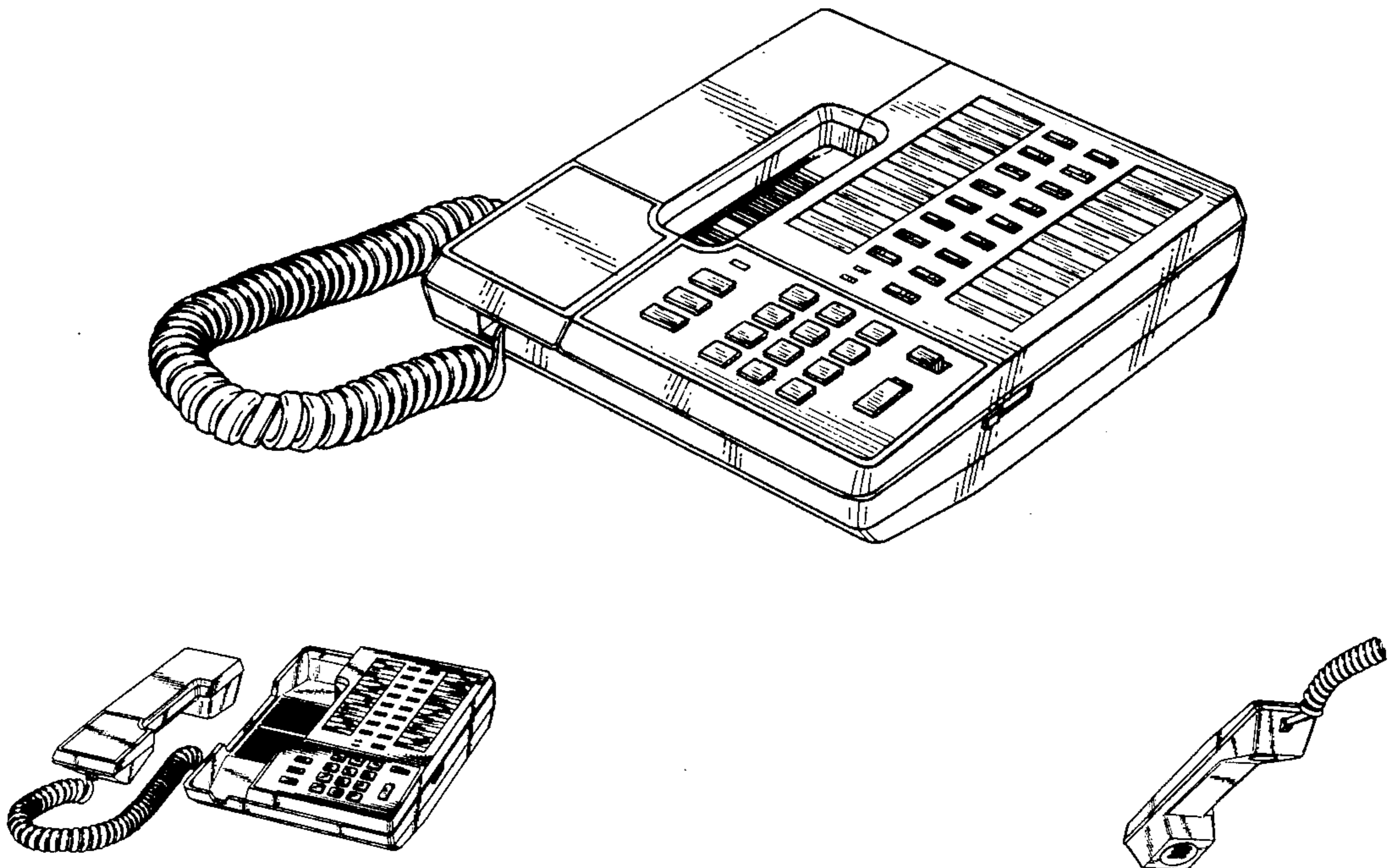

Fig. 1

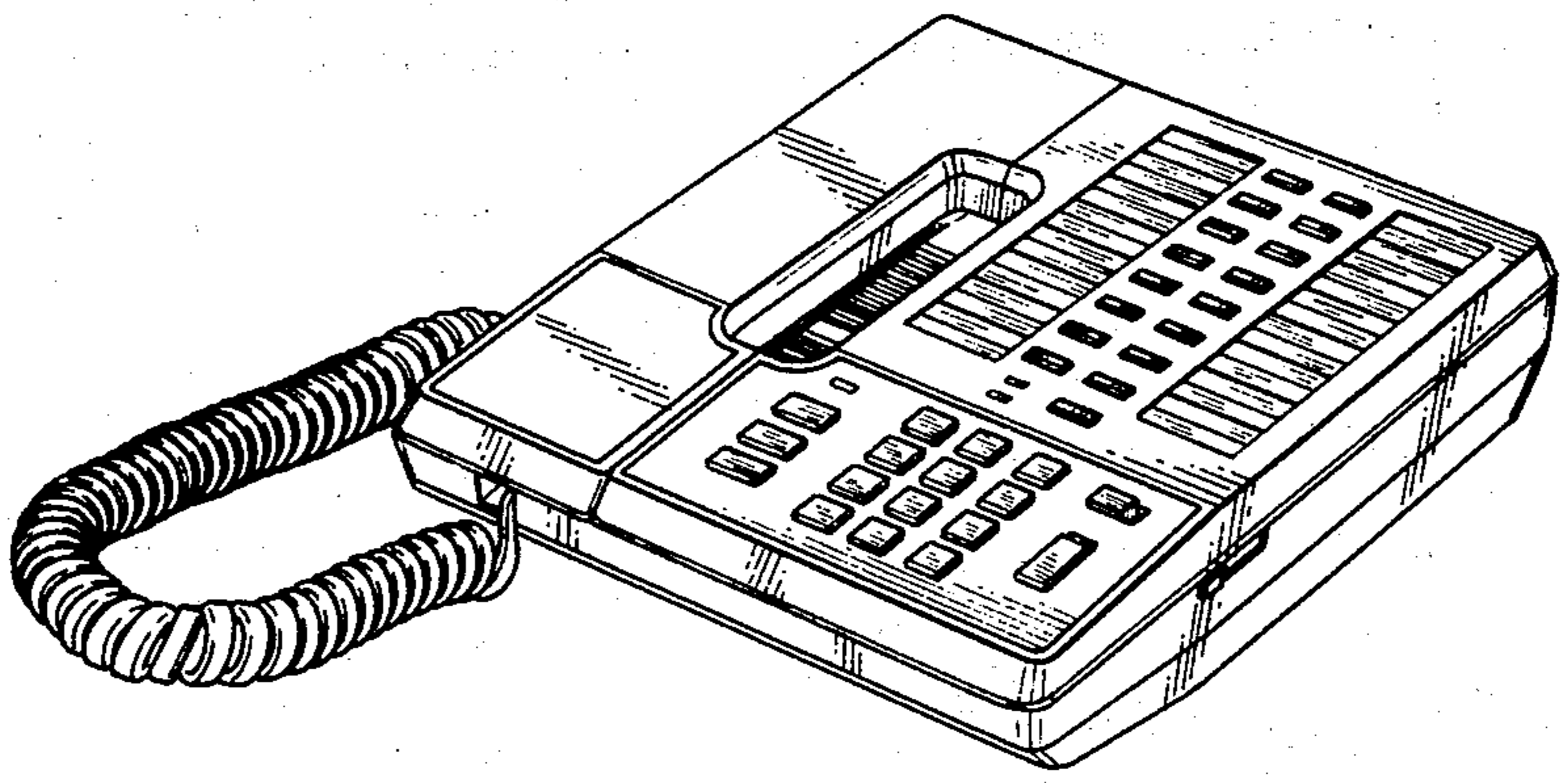

Fig. 2

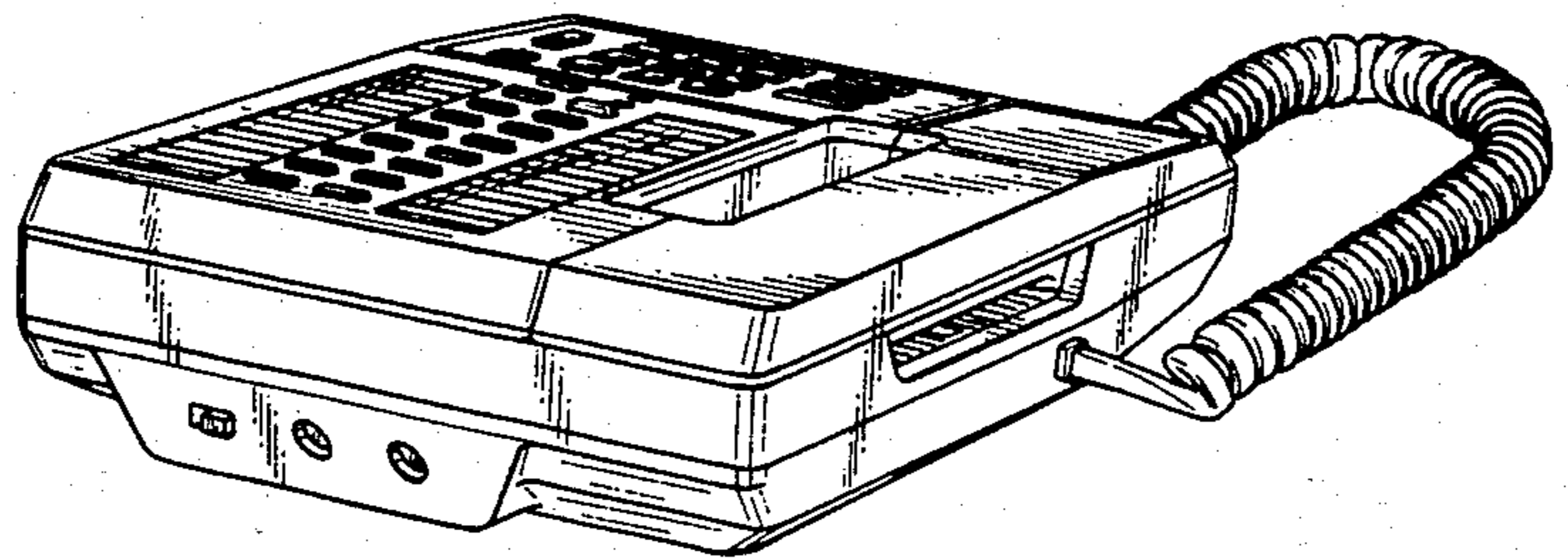

Fig. 3

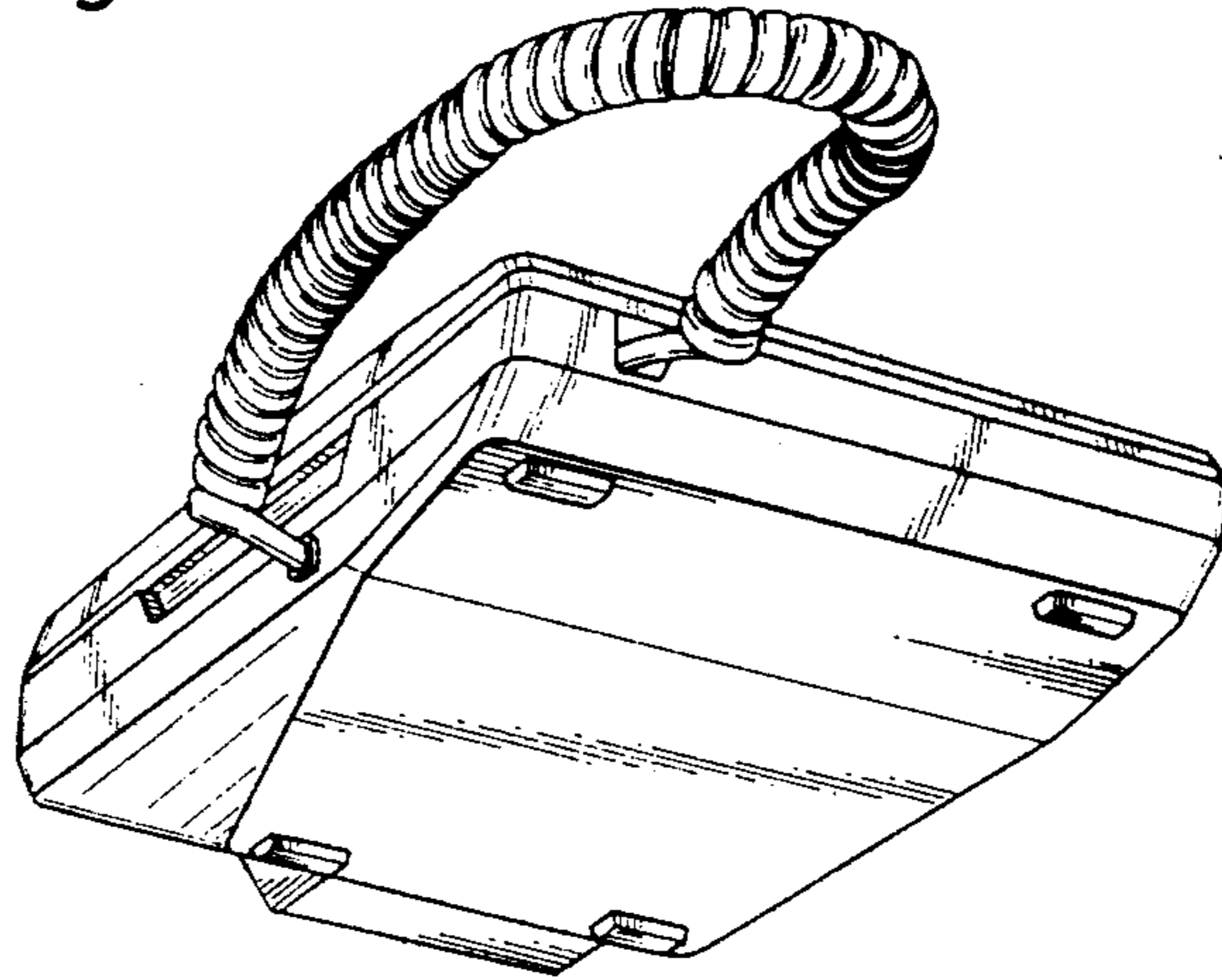

Fig. 4

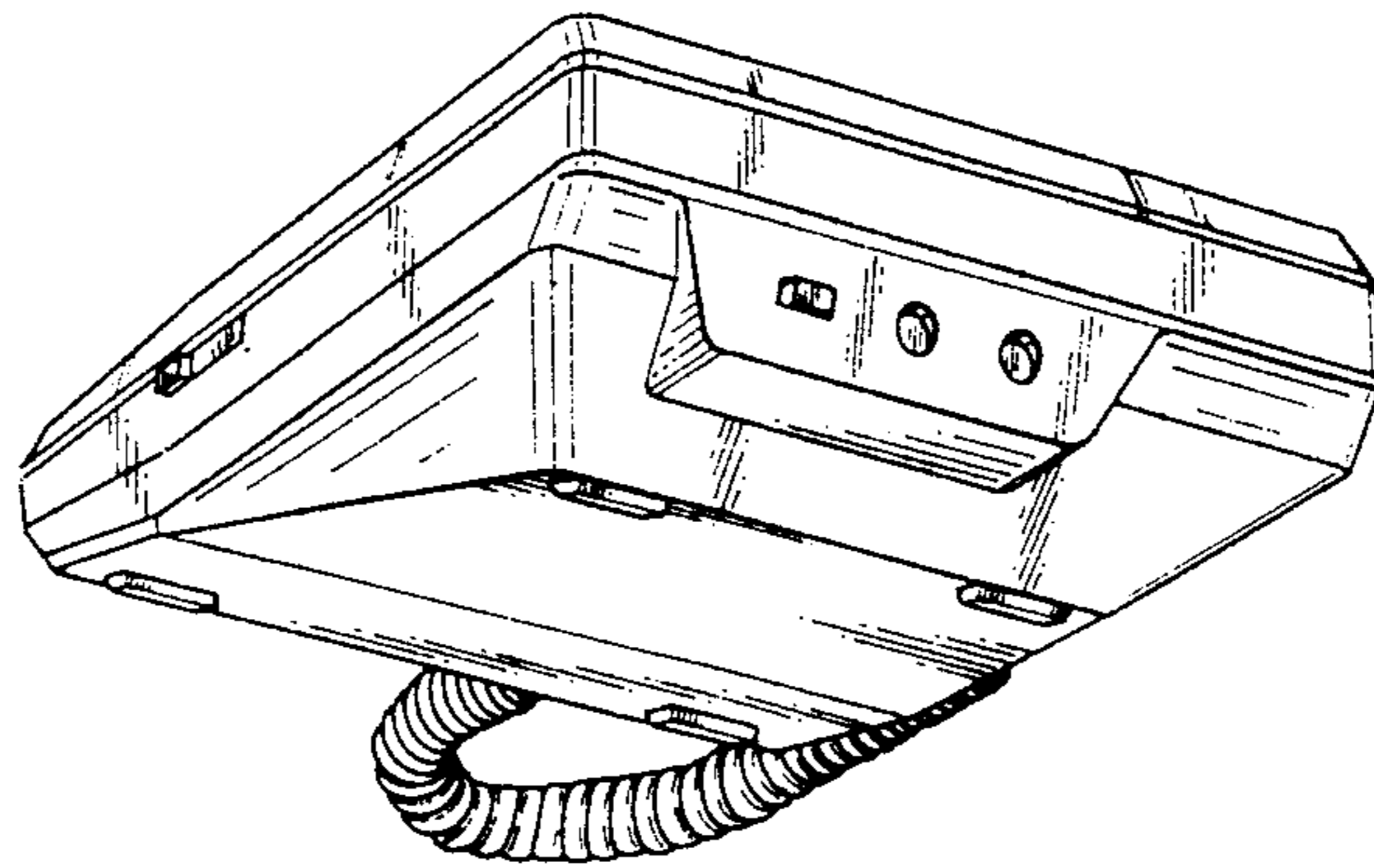

Fig. 5

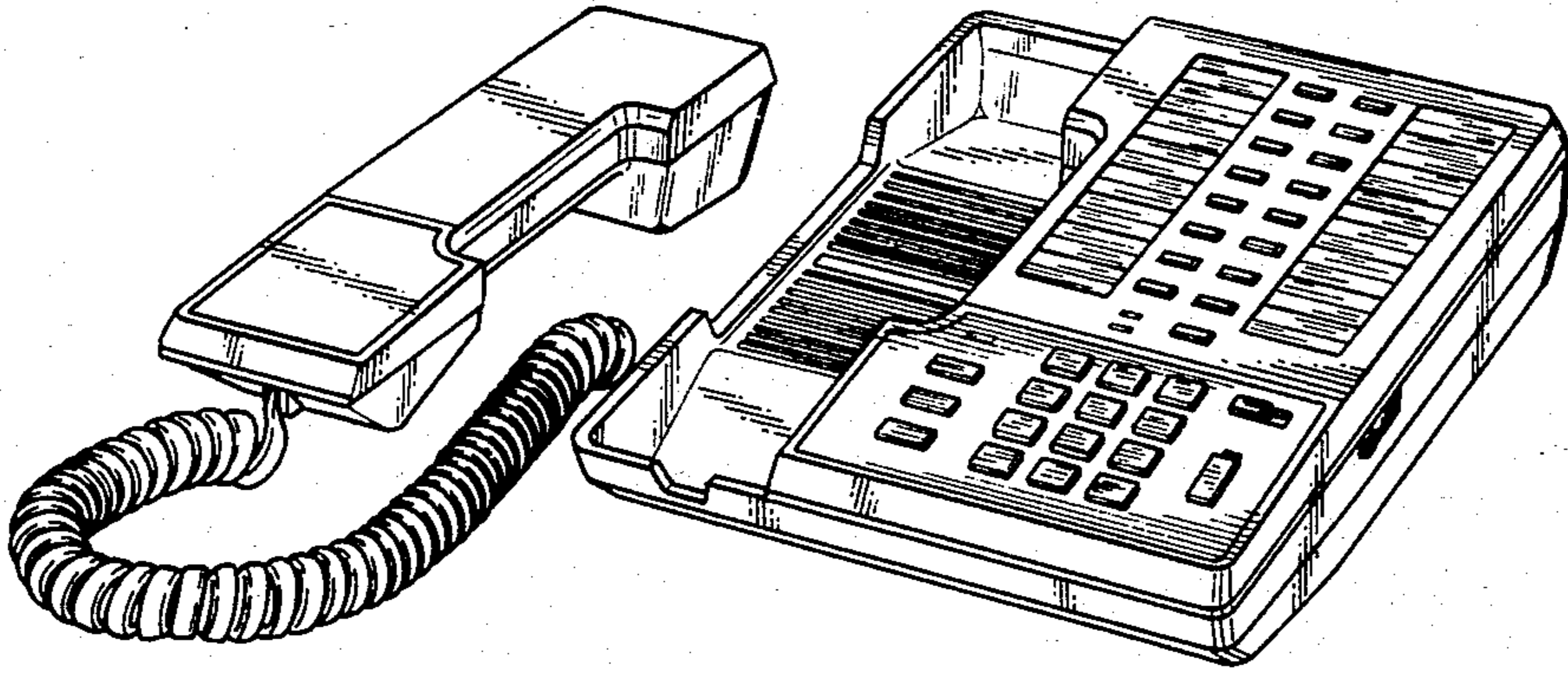

Fig. 6

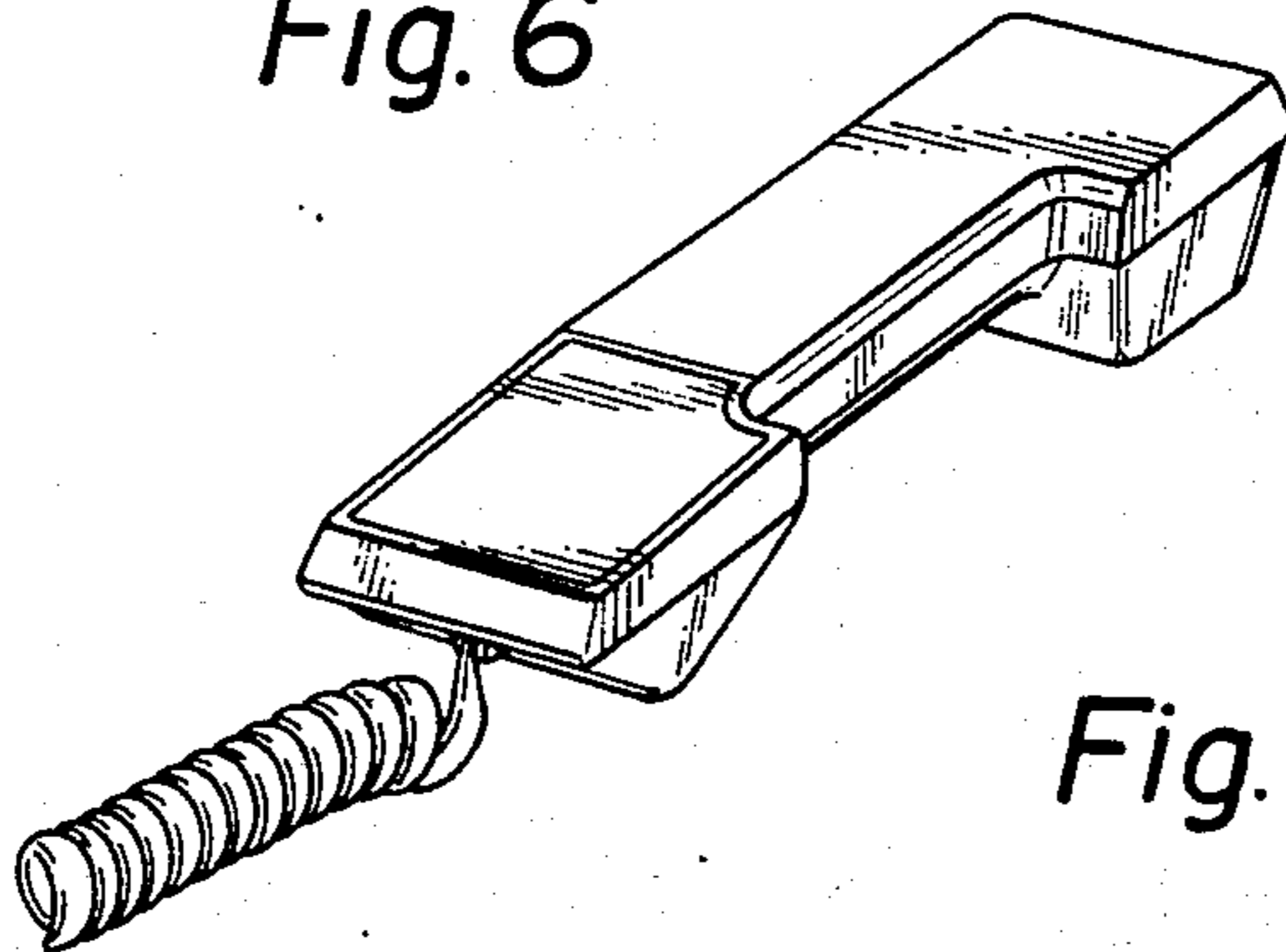

Fig. 7

