

[54] COMBINED WRISTWATCH AND TOY AIRCRAFT

[75] Inventor: Shigeru Nakane, Narashino, Japan

[73] Assignee: Takara Co., Ltd., Tokyo, Japan

[\*\*] Term: 14 Years

[21] Appl. No.: 608,387

[22] Filed: May 9, 1984

[52] U.S. Cl. .... D10/33; D21/87; D21/150; D10/37; D10/38

[58] Field of Search ..... D10/15, 30, 32, 33, D10/38, 39; D21/82-83, 87-90, 128, 144, 149-150, 166; D12/319-321, 335, 343; 368/10; 446/69, 71-72, 75-77, 487

[56] References Cited

U.S. PATENT DOCUMENTS

- D. 219,290 11/1970 Rosenthal ..... D21/87
- D. 275,586 9/1984 Matsuda ..... D21/144
- D. 278,643 4/1985 Ogawa ..... D21/150 X
- D. 279,804 7/1985 Ohno ..... D21/150 X
- D. 281,090 10/1985 Murakami ..... D21/150
- 4,456,384 6/1984 Murakami ..... 368/10
- 4,482,256 11/1984 Matsuda ..... 368/277 X

Primary Examiner—Nelson C. Holtje  
Attorney, Agent, or Firm—Price, Gess & Ubell

[57] CLAIM

The ornamental design for a combined wristwatch and toy aircraft, substantially as shown and described.

DESCRIPTION

FIG. 1 is a front side elevational view of a combined wristwatch and toy aircraft showing my new design, the rear side elevational view being substantially a mirror image thereto;

FIG. 2 is a top plan view thereof;

FIG. 3 is a bottom plan view thereof;

FIG. 4 is a right side elevational view of FIG. 6;

FIG. 5 is a left side elevational view of FIG. 6;

FIG. 6 is a top and left front perspective view of the toy aircraft watch with the holder/strap omitted for clarity of illustration;

FIG. 7 is a top and left front perspective view of the holder/strap with the toy aircraft watch omitted for clarity of illustration;

FIG. 8 is a front side elevational view of FIG. 6;

FIG. 9 is a side elevational view of FIG. 6;

FIG. 10 is a top plan view of FIG. 6;

FIG. 11 is a bottom plan view of FIG. 6;

FIG. 12 is a right side elevational view of FIG. 6;

FIG. 13 is a left side elevational view of FIG. 6;

FIG. 14 is an inverted right end elevational view of FIG. 6 reconfigured into the form of a toy aircraft;

FIG. 15 is a rear elevational view of FIG. 14;

FIG. 16 is a top plan view of FIG. 14;

FIG. 17 is a bottom plan view of FIG. 15;

FIG. 18 is a right side elevational view of FIG. 14;

FIG. 19 is a left side elevational view of FIG. 14;

FIG. 20 is a fragmentary top plan view of FIG. 7.

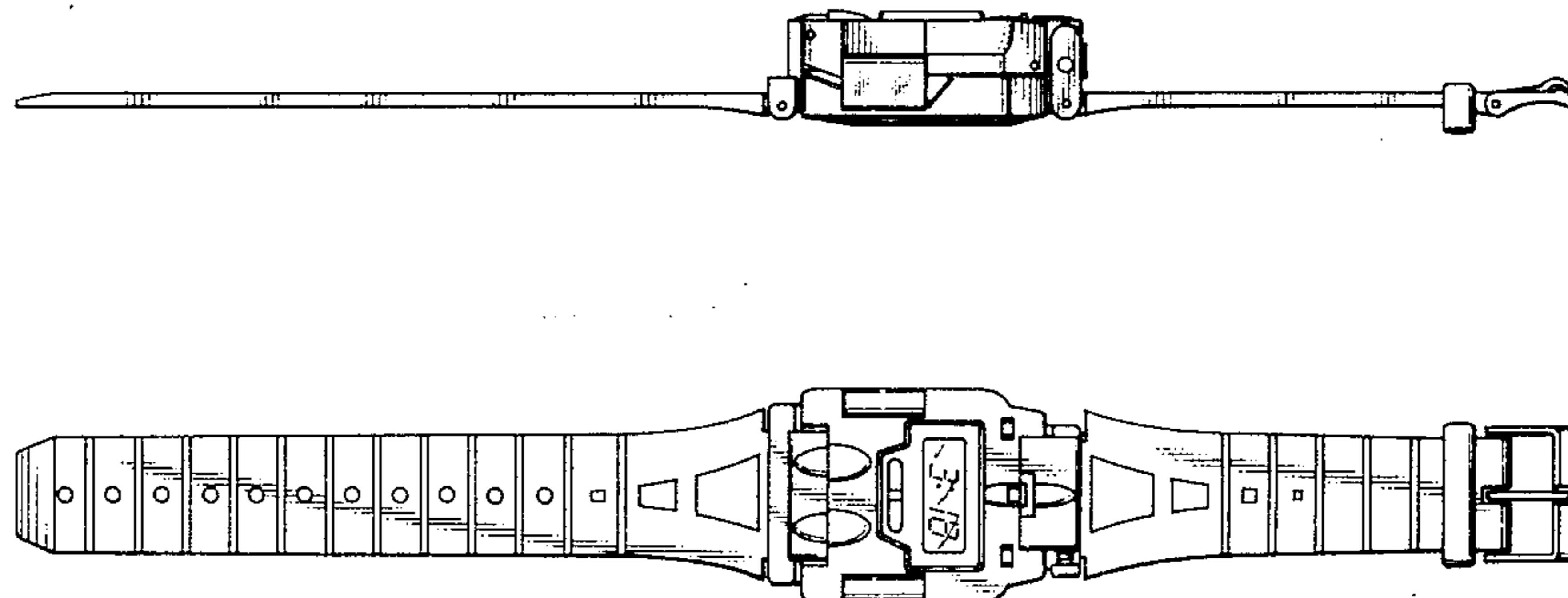

FIG.1

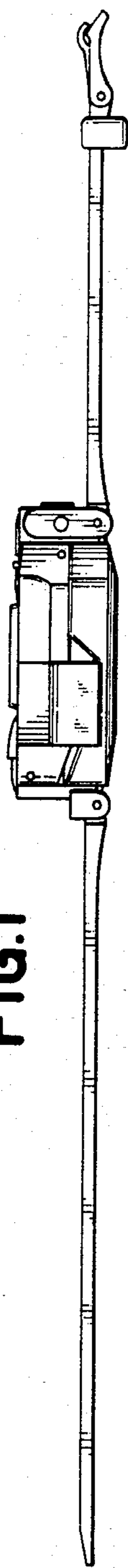

FIG.2

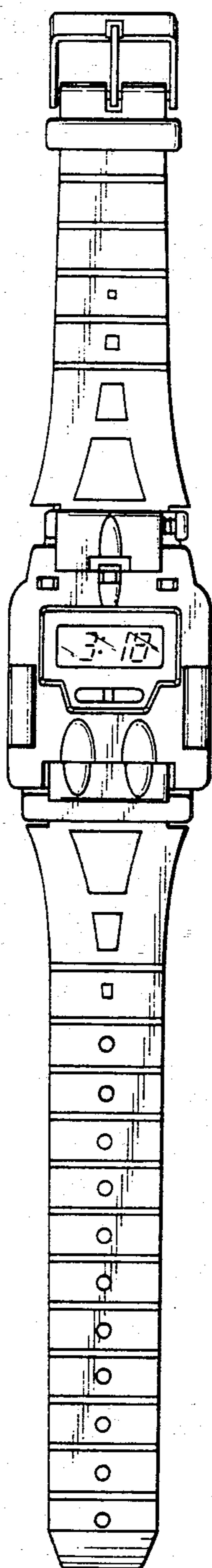

FIG.3

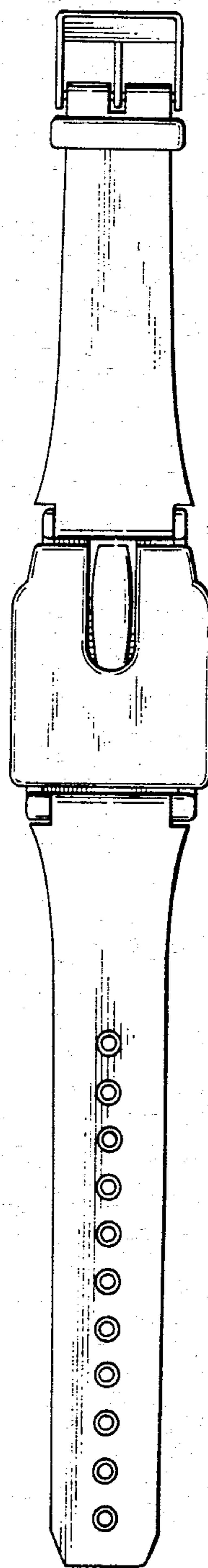

FIG.4

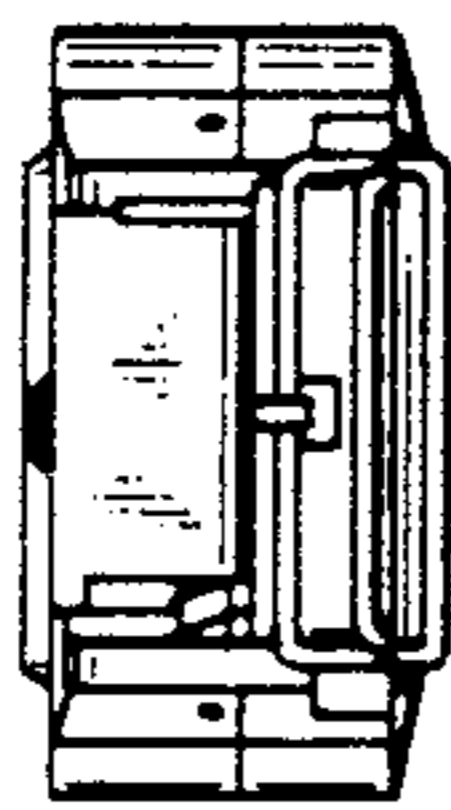

FIG.5



FIG.6

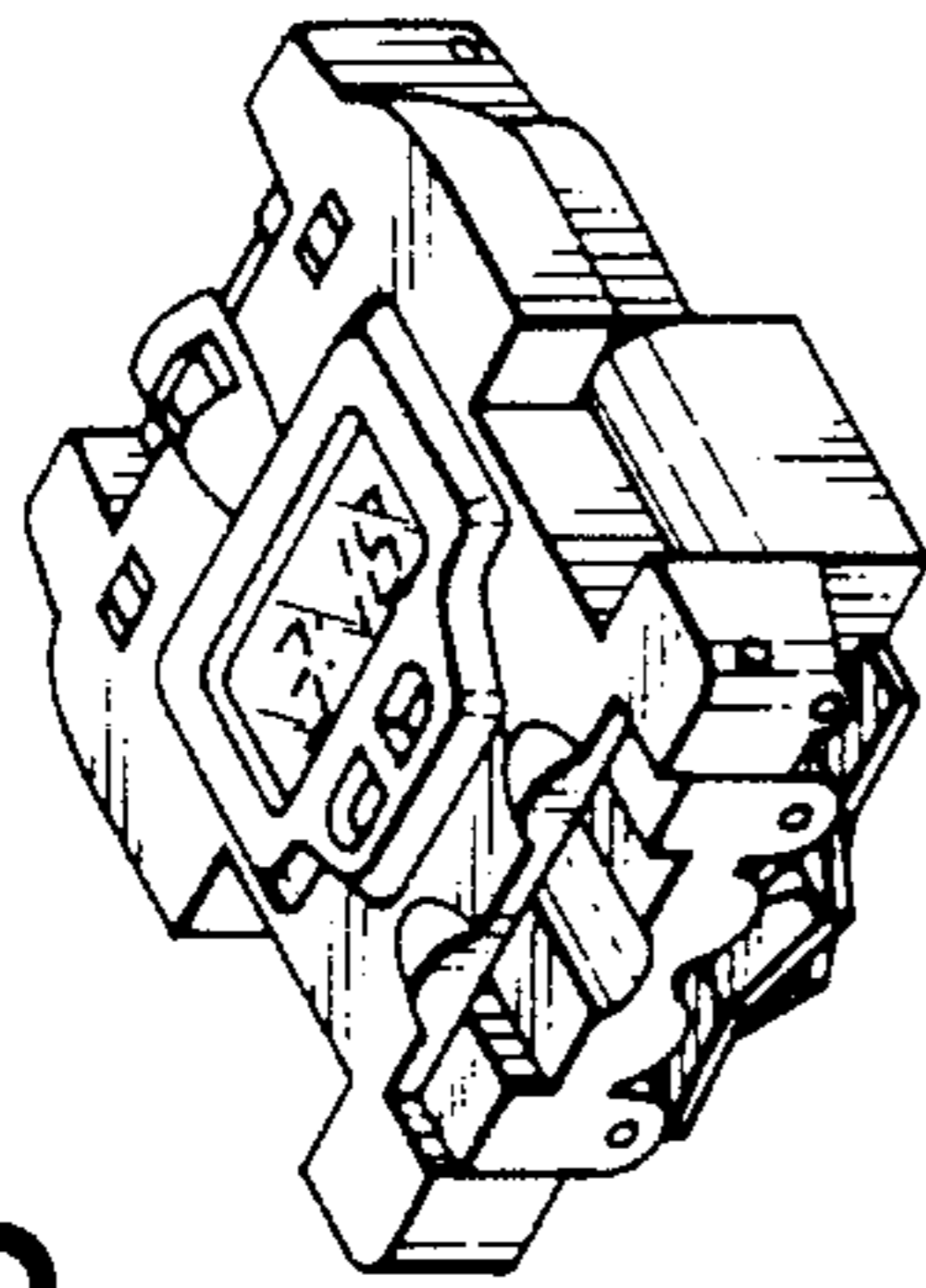

FIG.7

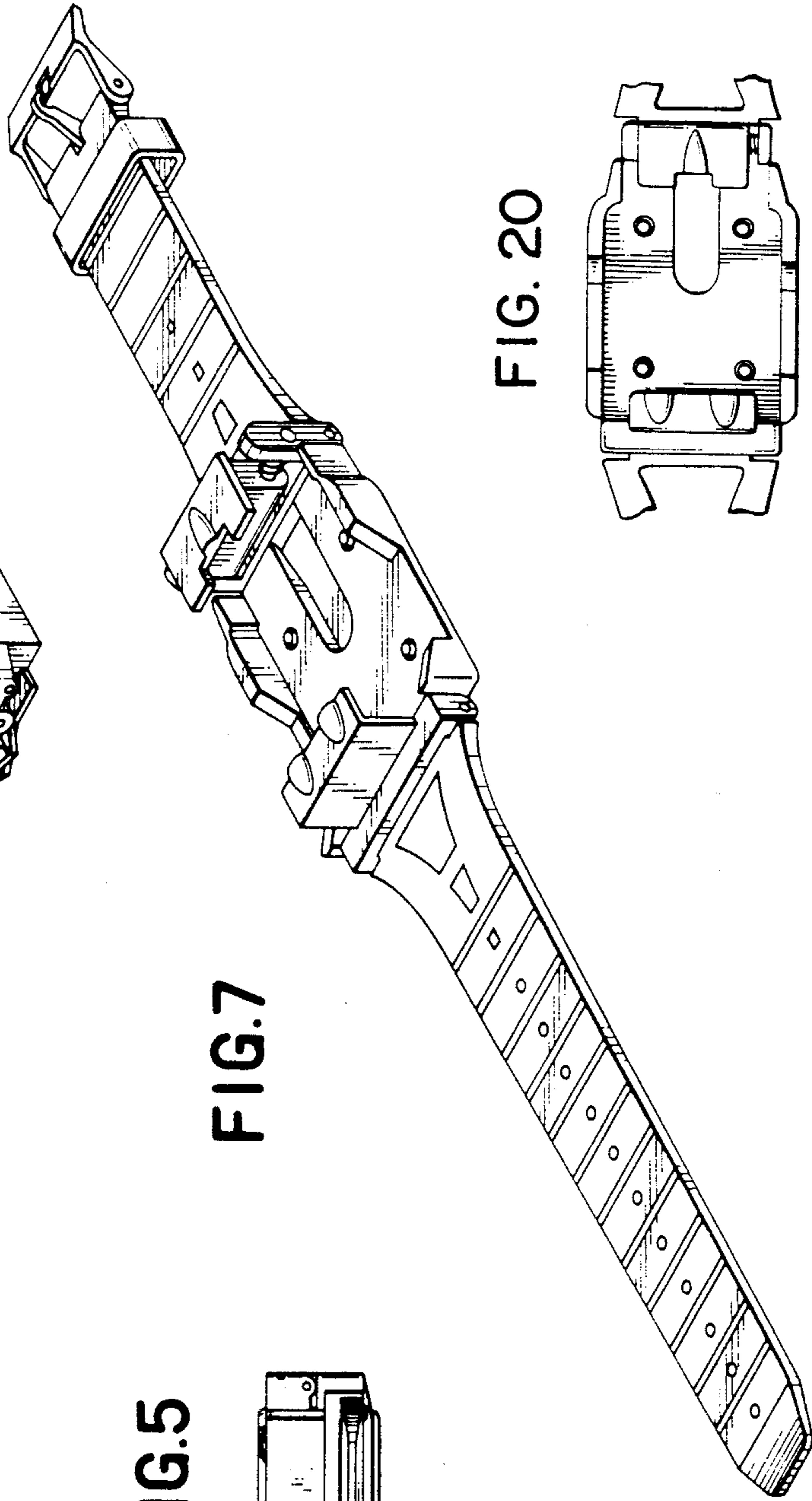
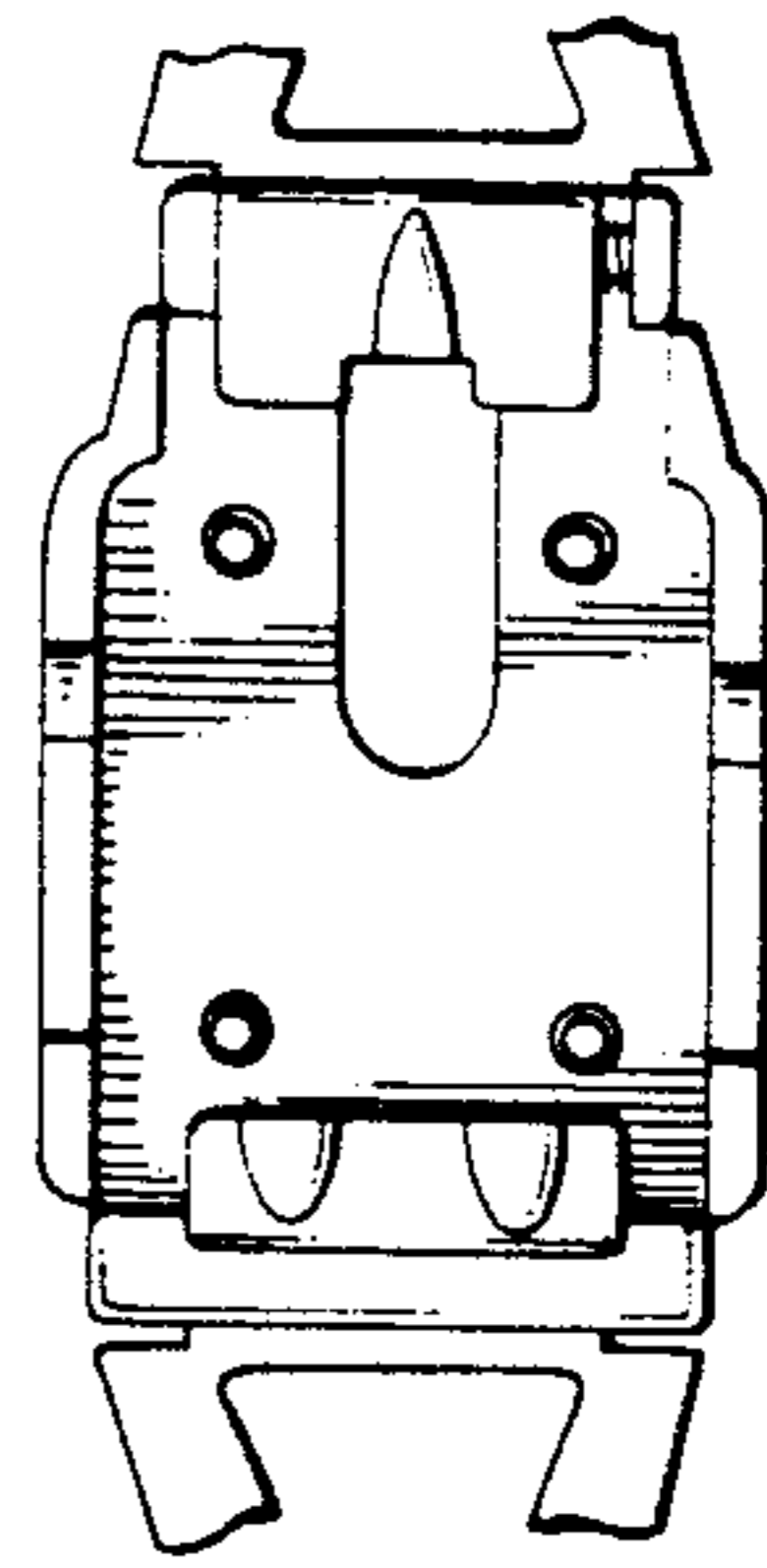
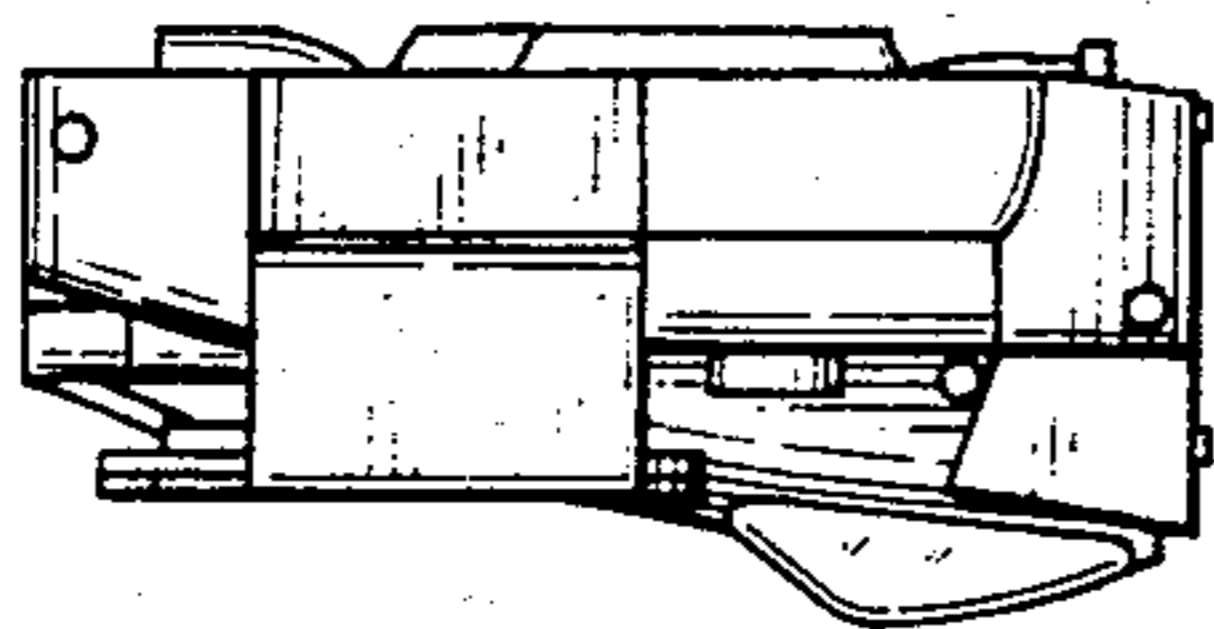

FIG. 20



**FIG.8**



**FIG.9**

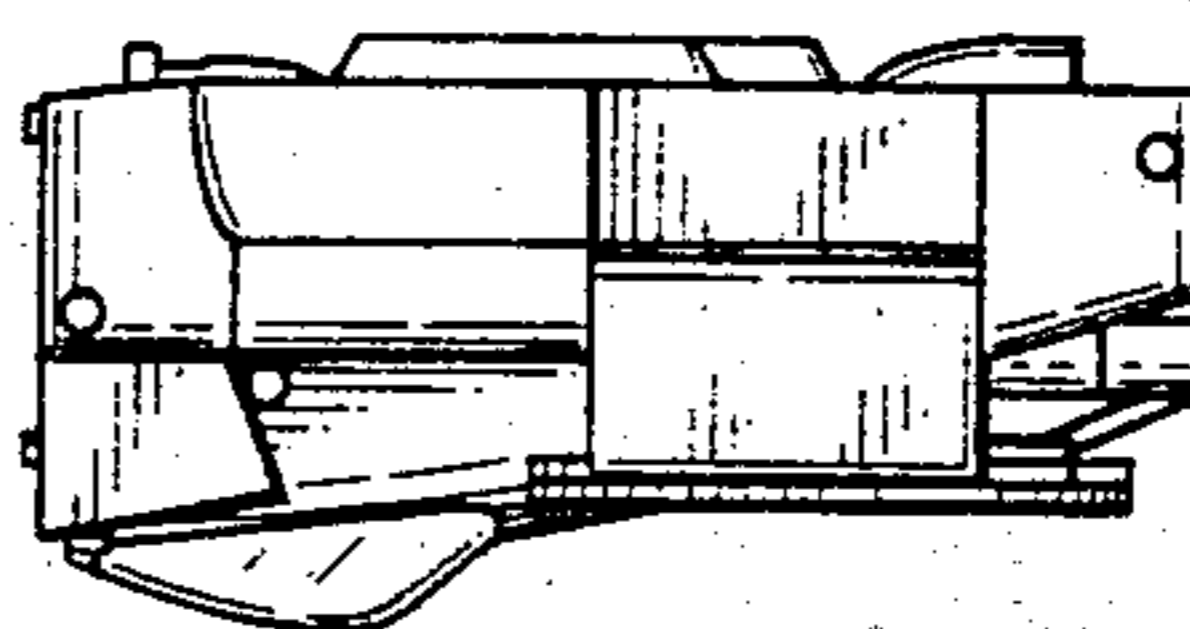

**FIG.10**

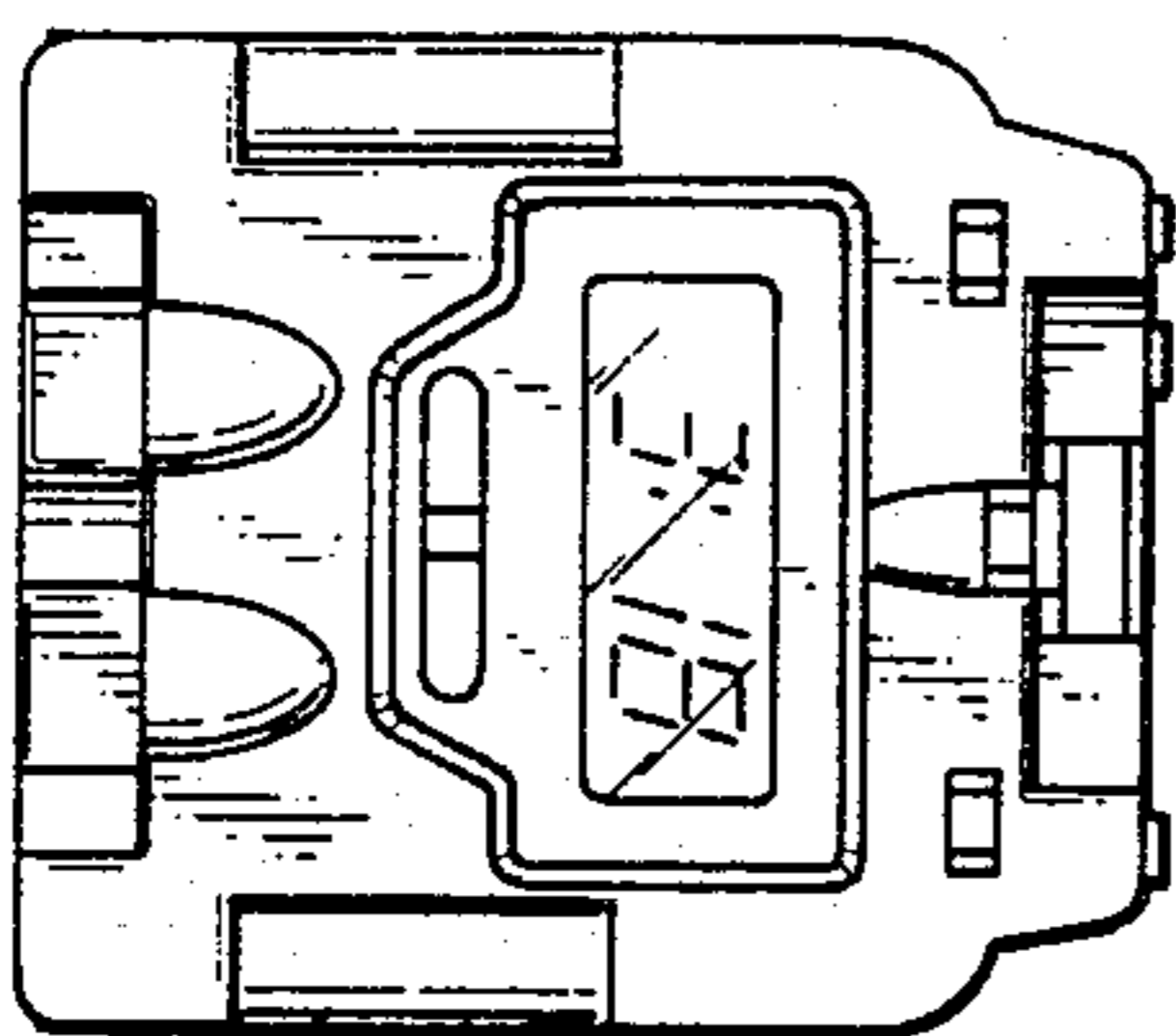

**FIG.12**

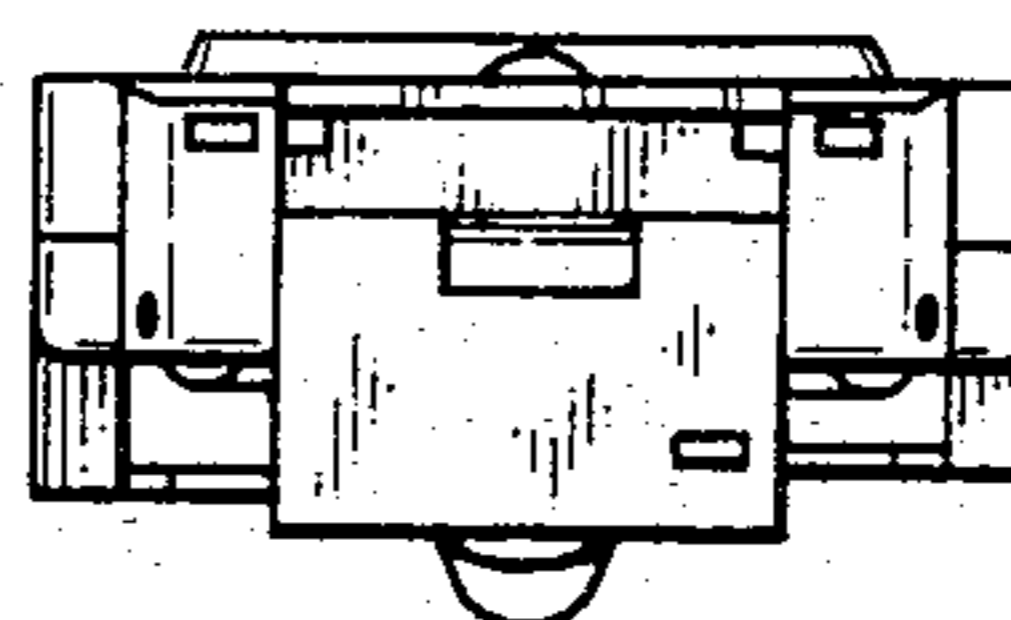

**FIG.11**

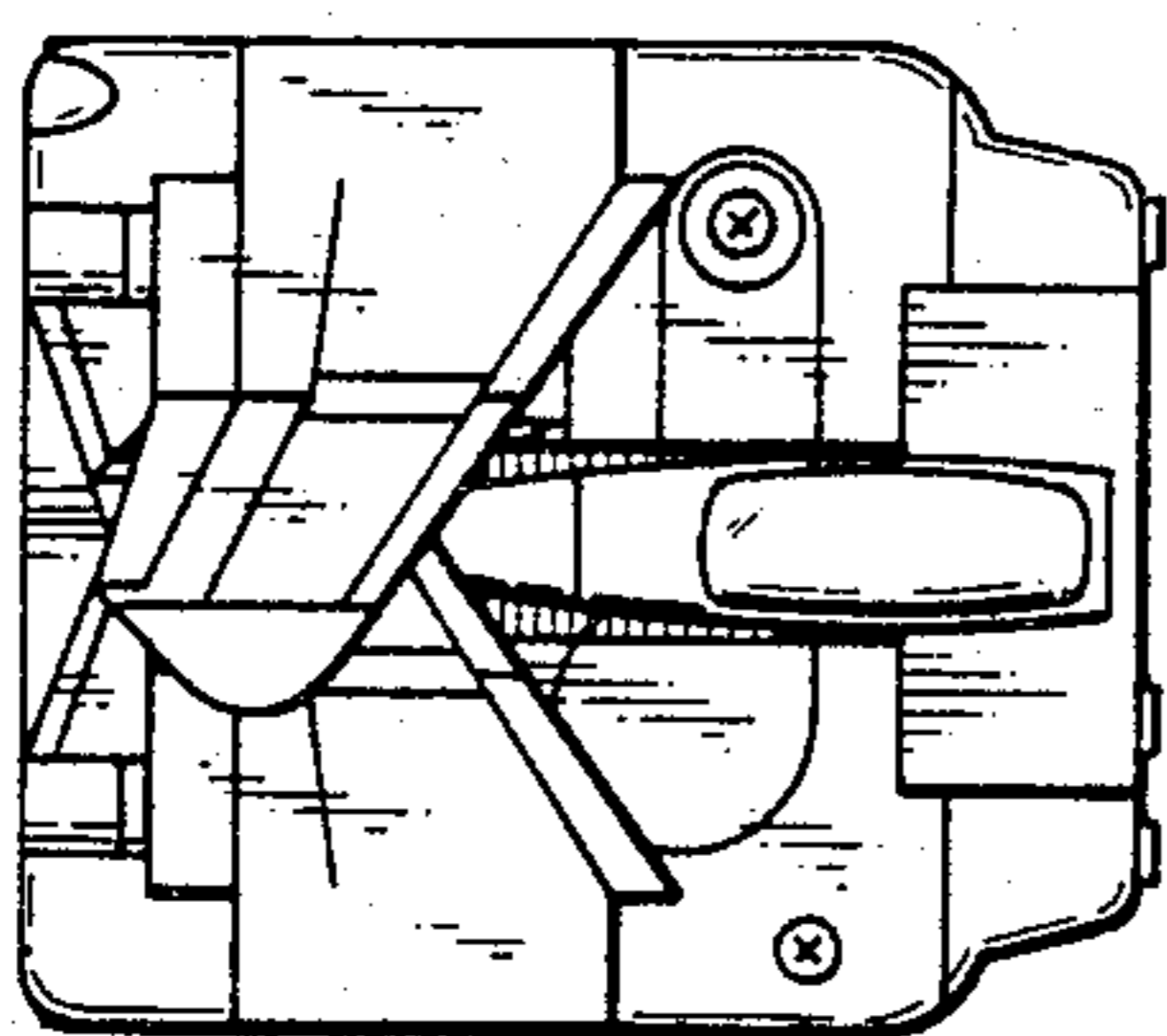

**FIG.13**

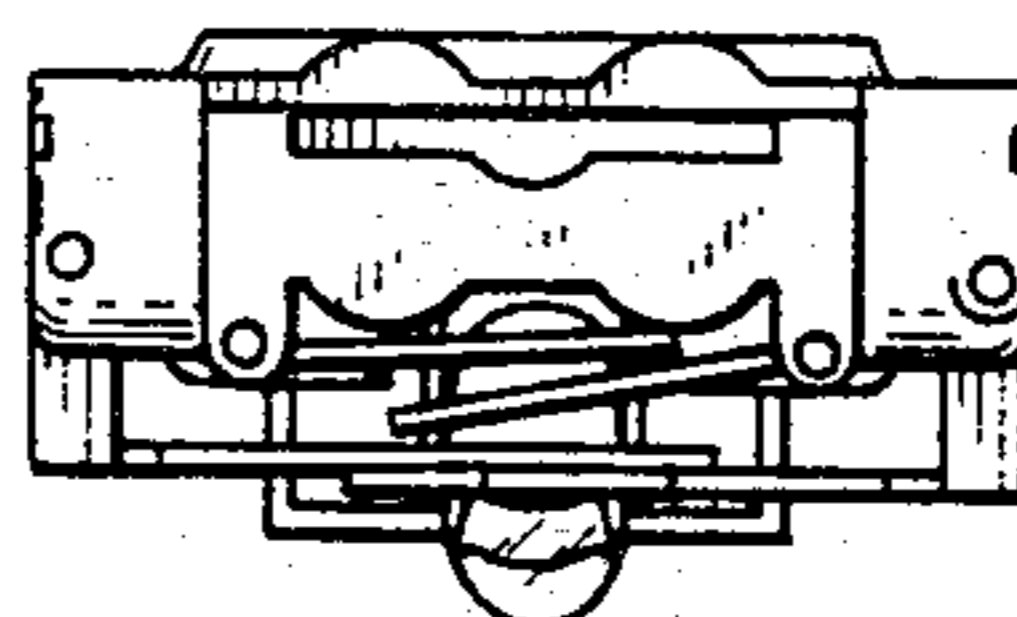

**FIG.14**

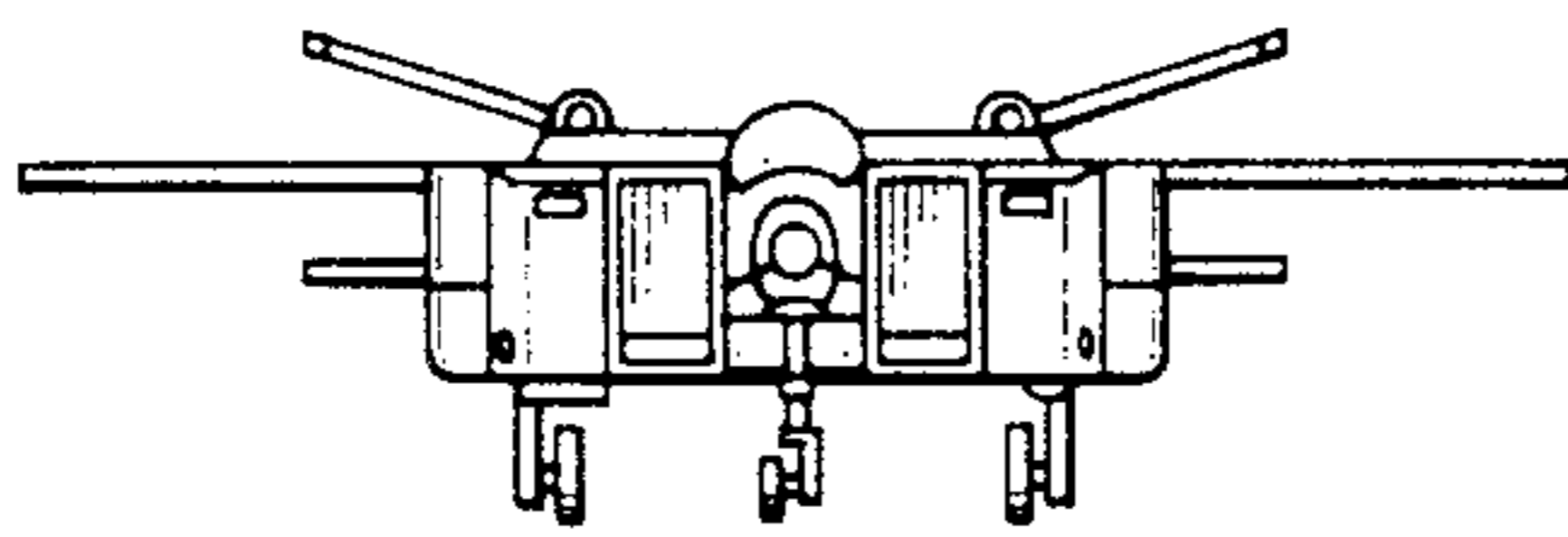

**FIG.15**

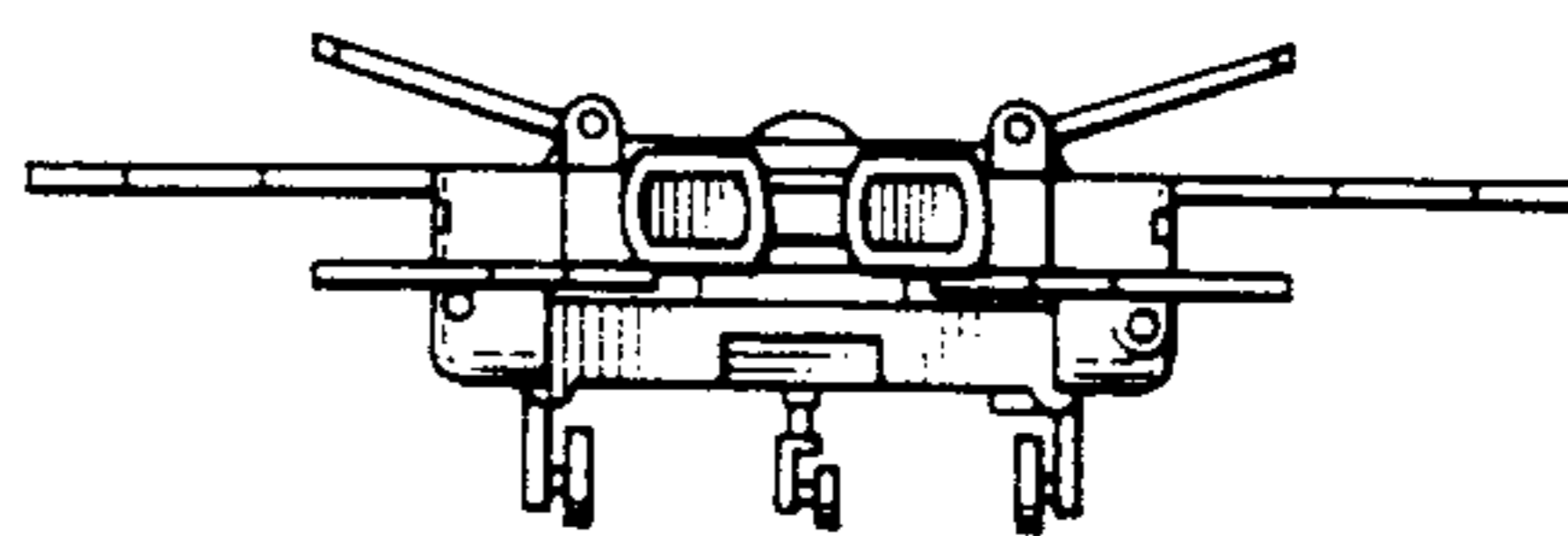

**FIG.16**

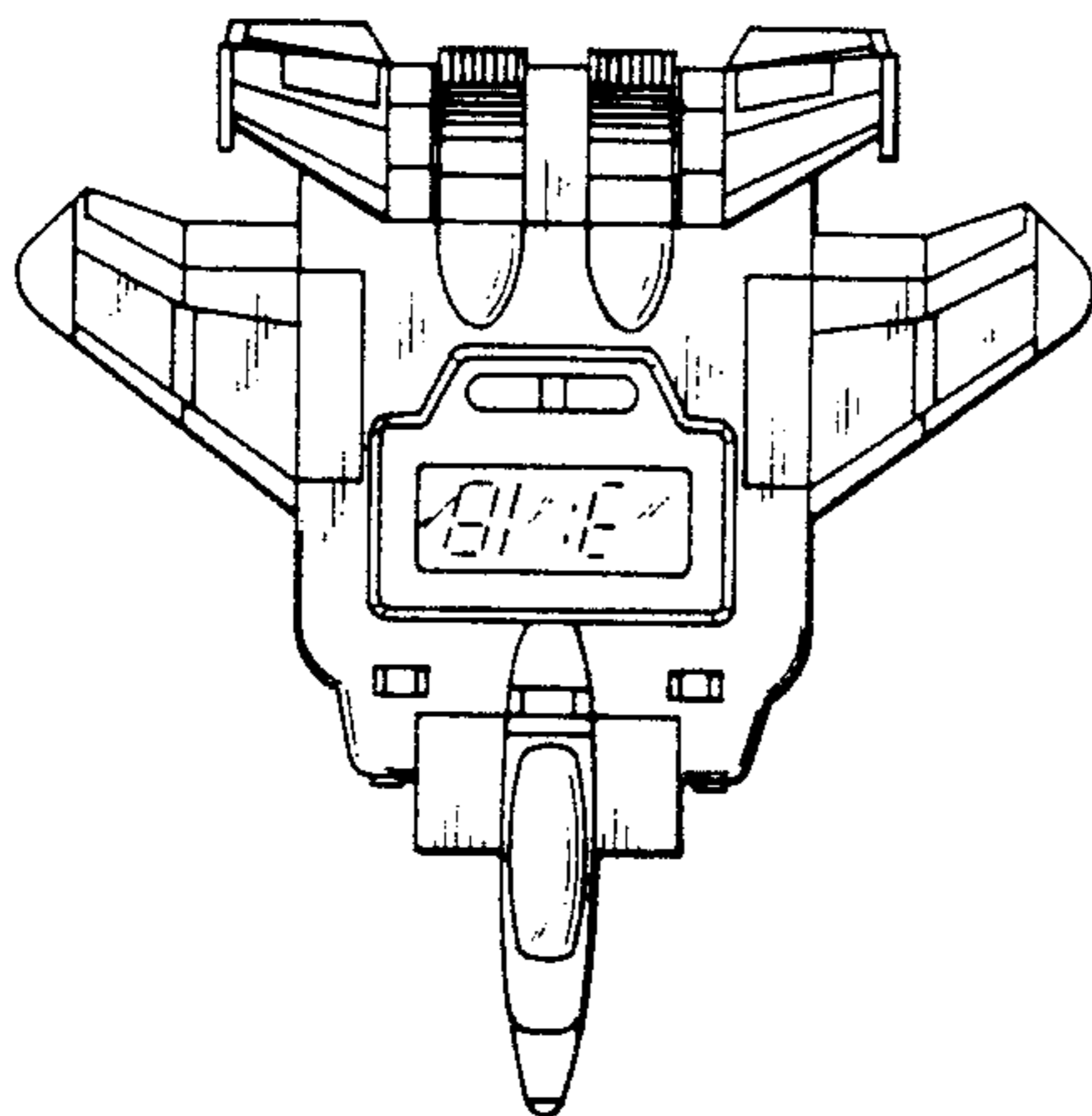

**FIG.17**

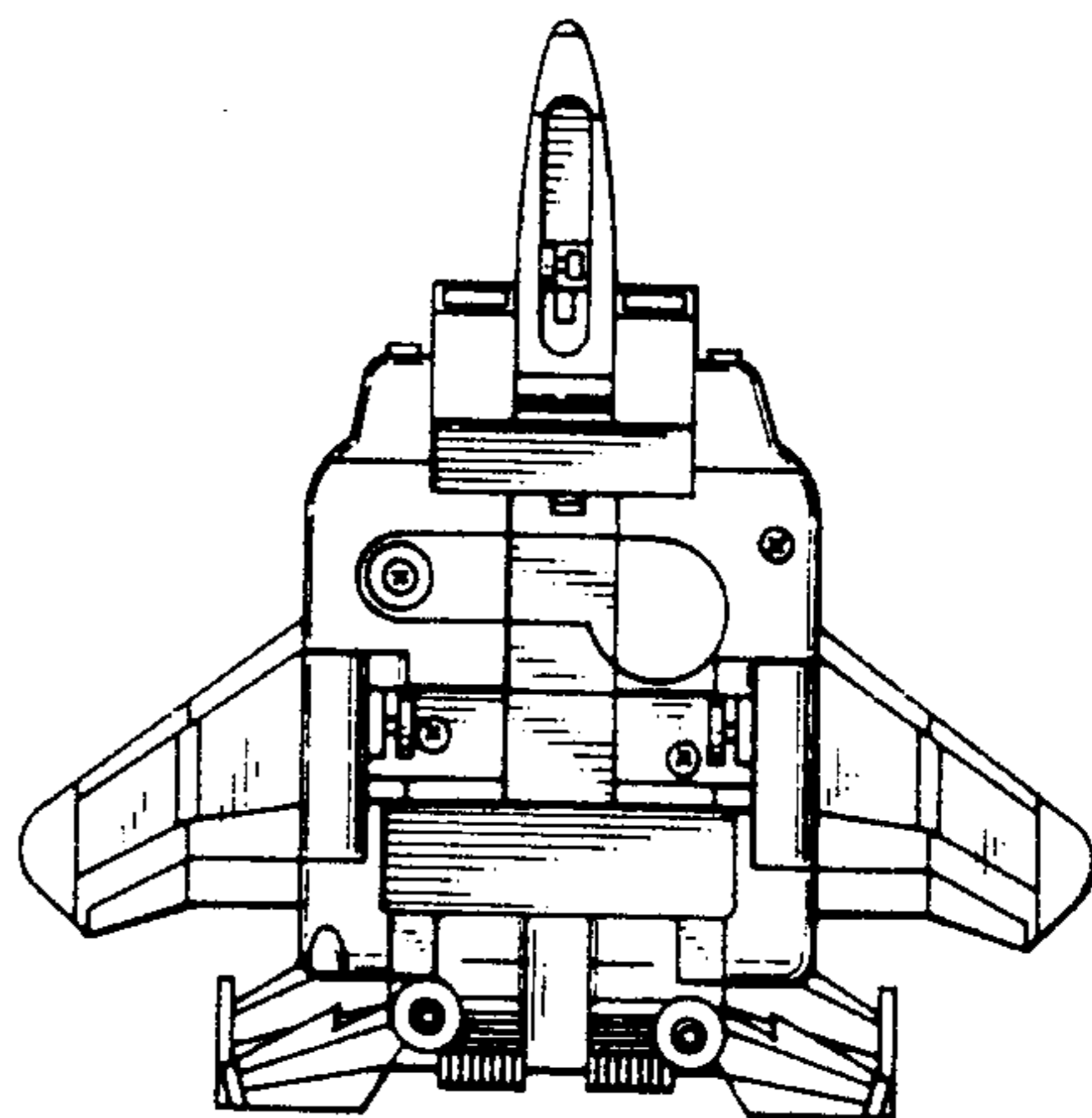

**FIG.18**

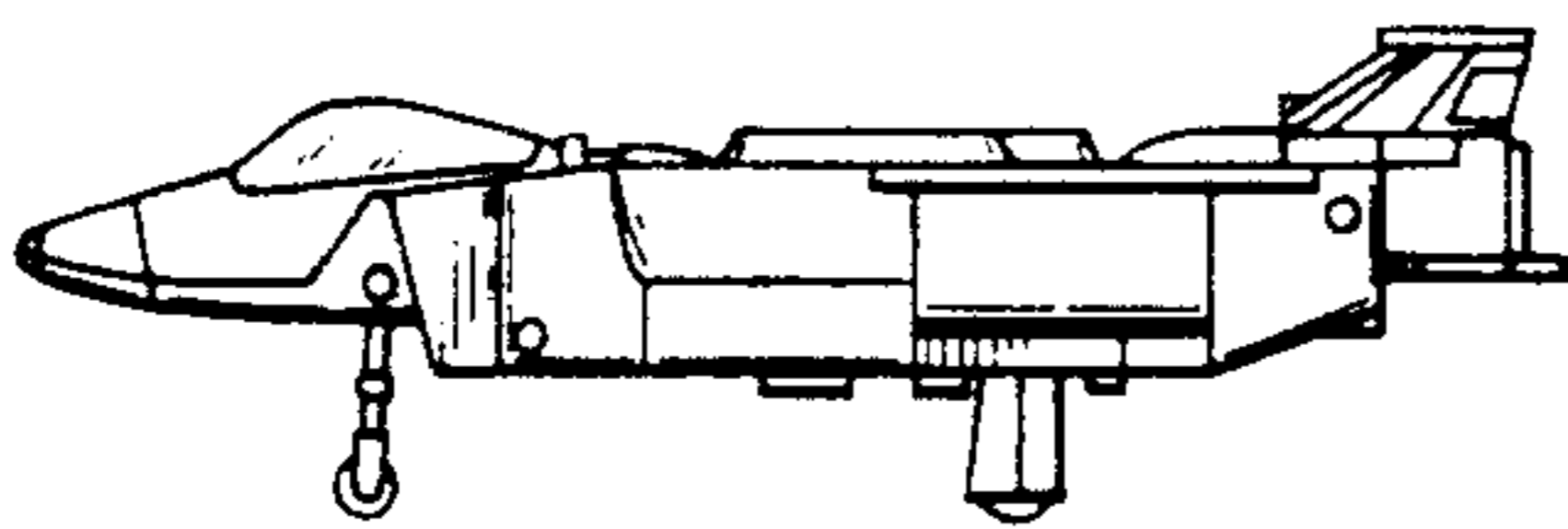

**FIG.19**

