

[54] **COMBINED CRANE AND TRAILER TOY**

[75] **Inventor: Gary E. Clark, Sikeston, Mo.**

[73] **Assignees: G. Weber Gilmore, Sikeston; Richard G. Heywood, Kirkwood, both of Mo. ; part interest to each**

[**] **Term: 14 Years**

[21] **Appl. No.: 596,039**

[22] **Filed: Apr. 2, 1984**

[52] **U.S. Cl. D21/132**

[58] **Field of Search D21/128, 132, 134, 135, D21/136; 446/439, 448, 450, 451, 454, 452, 456, 465, 469, 470, 427**

[56] **References Cited**

U.S. PATENT DOCUMENTS

D. 144,588	4/1946	Samuels	D21/132
D. 215,166	9/1969	Richardson	D21/132
D. 230,287	2/1974	DeGraw	D21/135
D. 267,100	11/1982	Magnusson	D21/132
2,066,644	1/1937	Raizen	D21/135

Primary Examiner—Charles A. Rademaker
Attorney, Agent, or Firm—Richard G. Heywood

[57] **CLAIM**

The ornamental design for a combined crane and trailer toy, substantially as shown and described.

DESCRIPTION

FIG. 1 is a perspective view of a combined crane and trailer toy showing my new design; FIG. 2 is a top plan view thereof; and, FIG. 3 is a side elevational view thereof, the side opposite being substantially a mirror image.

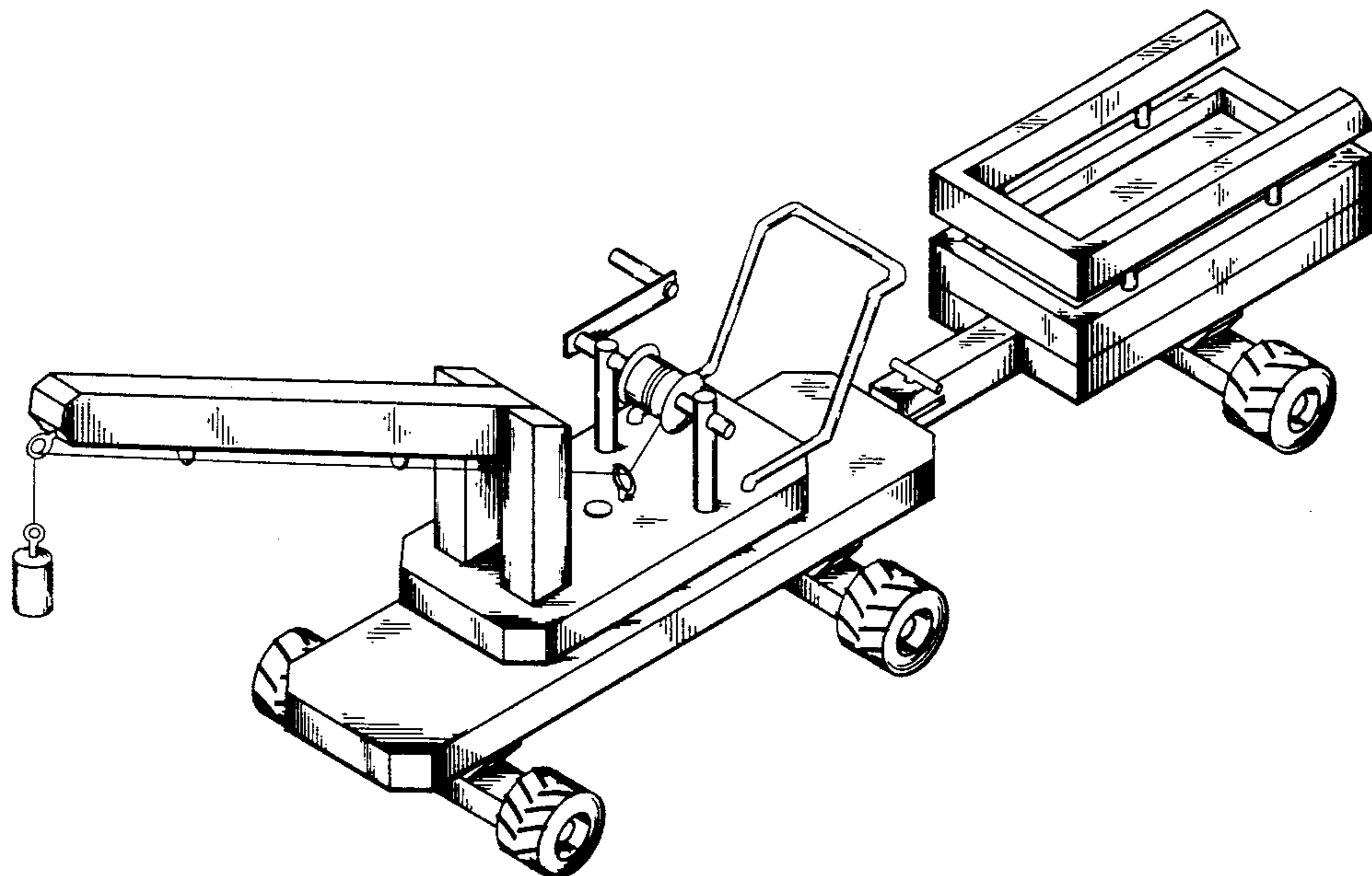

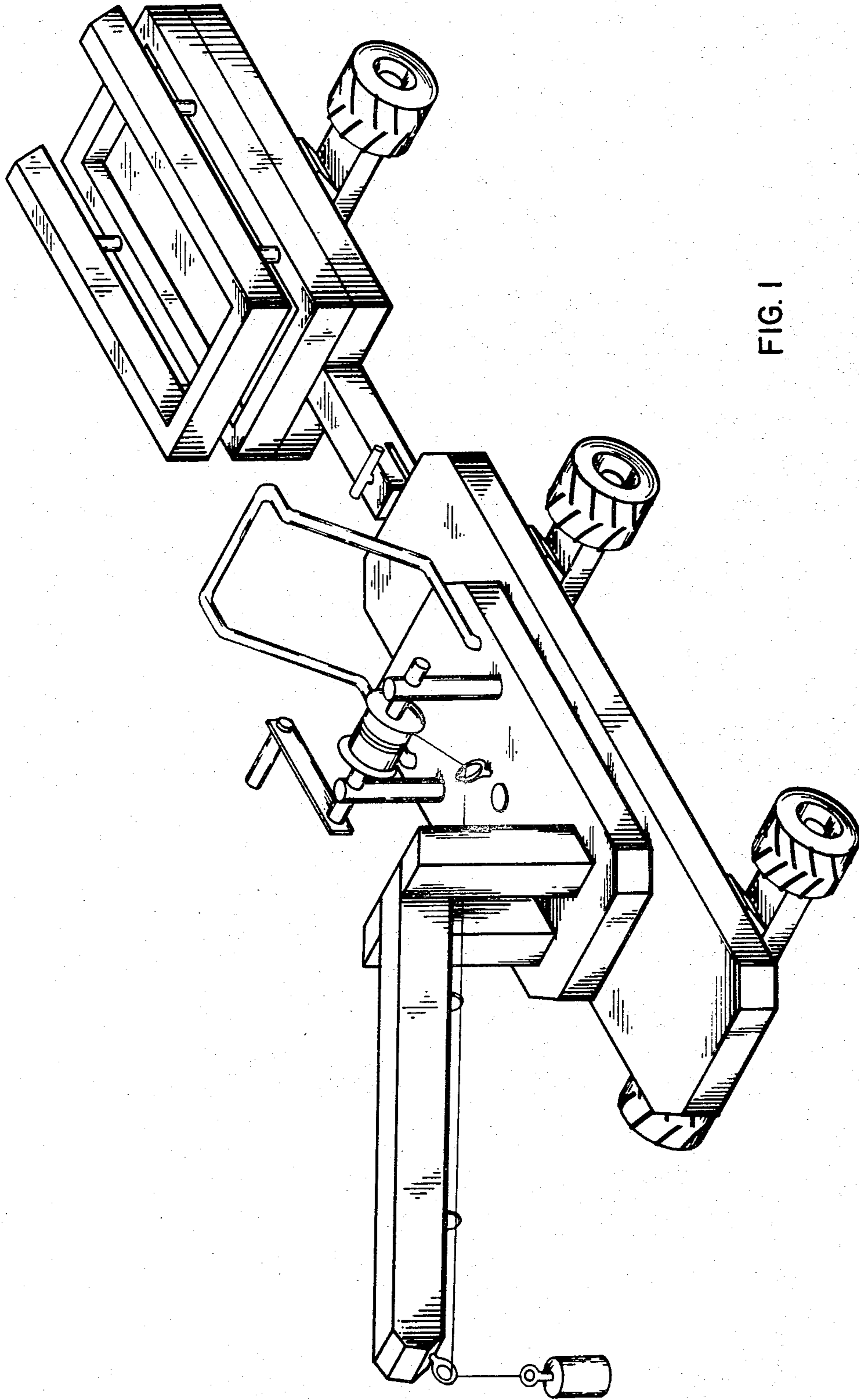

FIG. 1

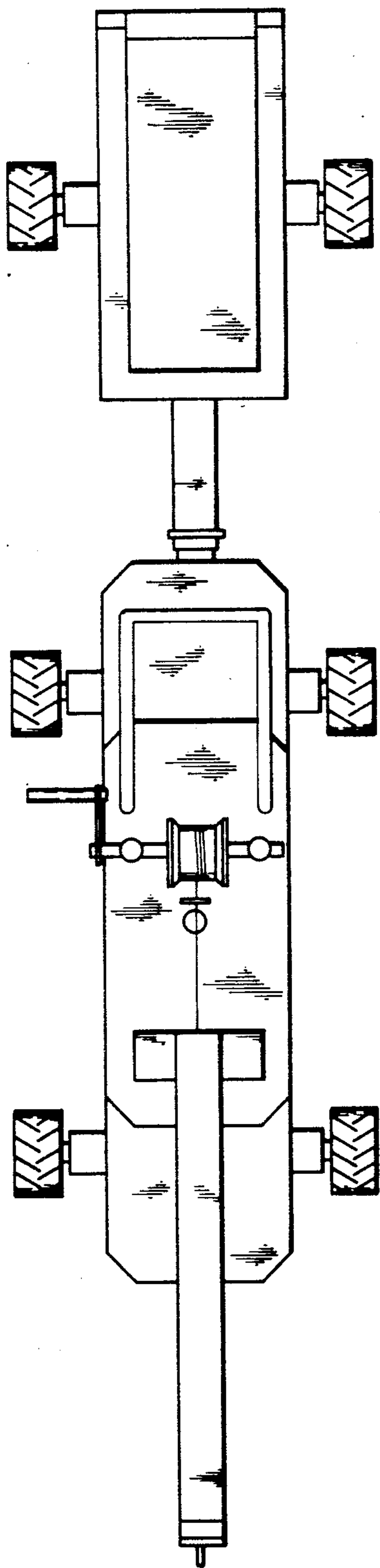

FIG. 2

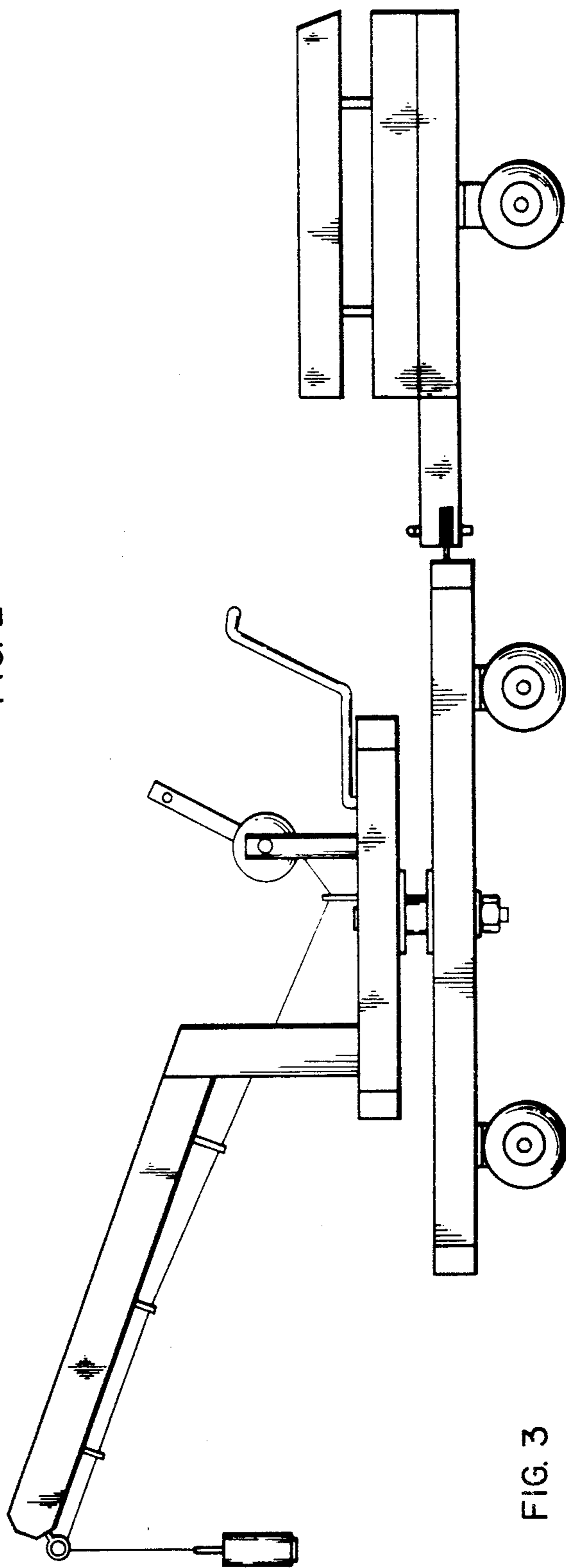

FIG. 3