

[54] CLEARANCE LAMP FOR AN AUTOMOBILE

[75] Inventor: Yoshihiro Hamasaki, Toyota, Japan

[73] Assignee: Toyota Jidosha Kabushiki Kaisha, Aichi, Japan

[**] Term: 14 Years

[21] Appl. No.: 606,595

[22] Filed: May 3, 1984

[52] U.S. Cl. D26/28; D26/120

[58] Field of Search D26/28, 29, 35, 120, D26/122; 362/61, 80, 81, 82, 83, 326-340

[56] References Cited

U.S. PATENT DOCUMENTS

- D. 271,142 10/1983 Hirasawa D26/120
- D. 271,143 10/1983 Hirakawa D26/120
- 4,198,674 4/1980 Ilhage et al. 362/80

FOREIGN PATENT DOCUMENTS

- 2656755 6/1978 Fed. Rep. of Germany 362/61
- 2935409 3/1981 Fed. Rep. of Germany 362/61
- 571241 11/1981 Japan .
- 577838 3/1982 Japan .
- 622766 1/1984 Japan .
- 622867 1/1984 Japan .

Primary Examiner—Susan J. Lucas
Attorney, Agent, or Firm—Cushman, Darby & Cushman

[57] CLAIM

The ornamental design for a clearance lamp for an automobile, as shown and described.

DESCRIPTION

FIG. 1 is a front perspective view of a clearance lamp for an automobile showing my new design;

FIG. 2 is a front elevational view thereof, on a reduced scale;

FIG. 3 is a rear elevational view thereof, on a reduced scale;

FIG. 4 is a left side elevational view thereof, on a reduced scale;

FIG. 5 is a right side elevational view thereof, on a reduced scale;

FIG. 6 is a top plan view thereof on a reduced scale;

FIG. 7 is a bottom plan view thereof, on a reduced scale;

FIG. 8 is a cross-sectional view taken along line VIII—VIII of FIG. 2; and

FIG. 9 is a perspective view thereof on a greatly reduced scale, the automobile being shown in broken lines for illustrative purposes only.

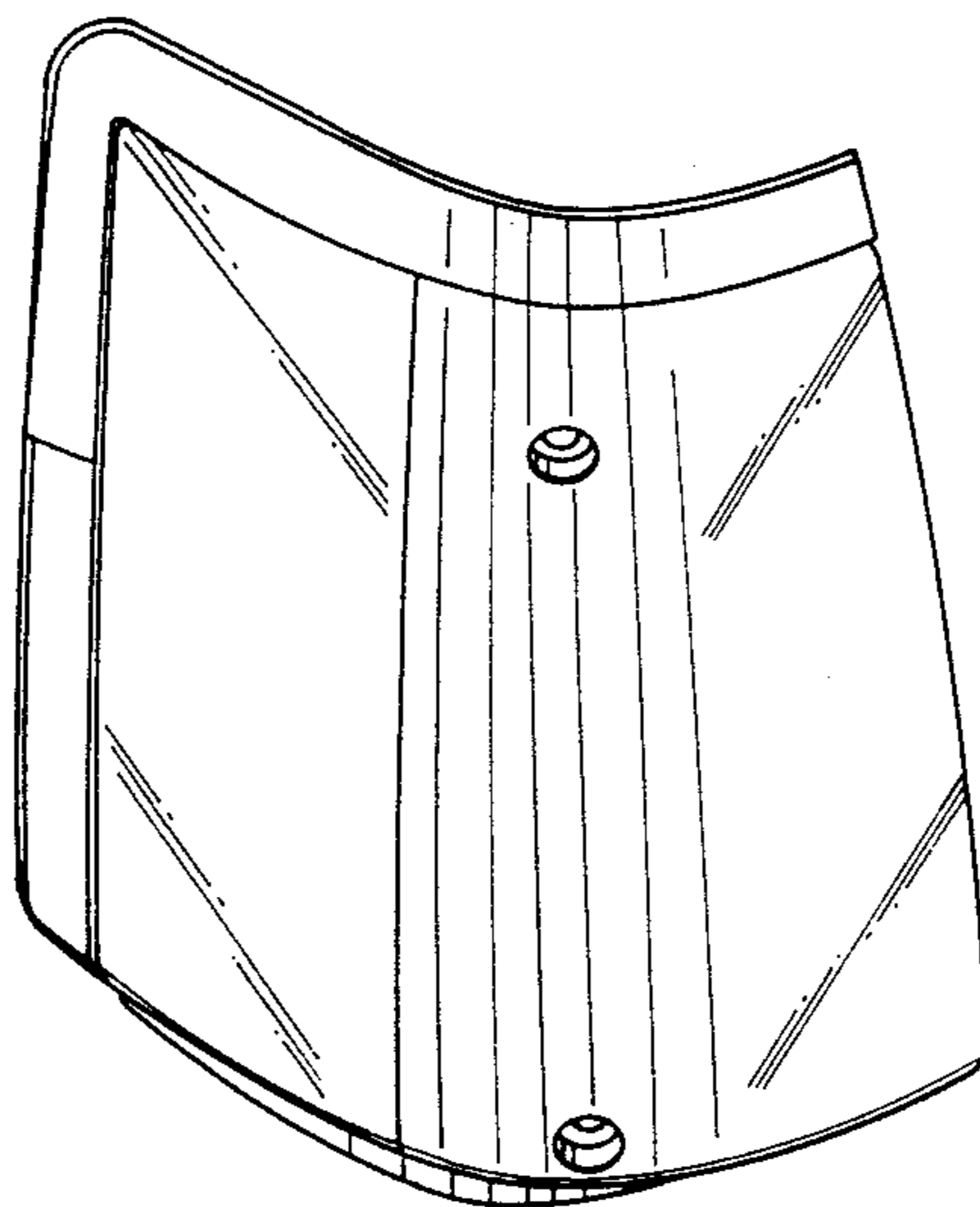

Fig. 1

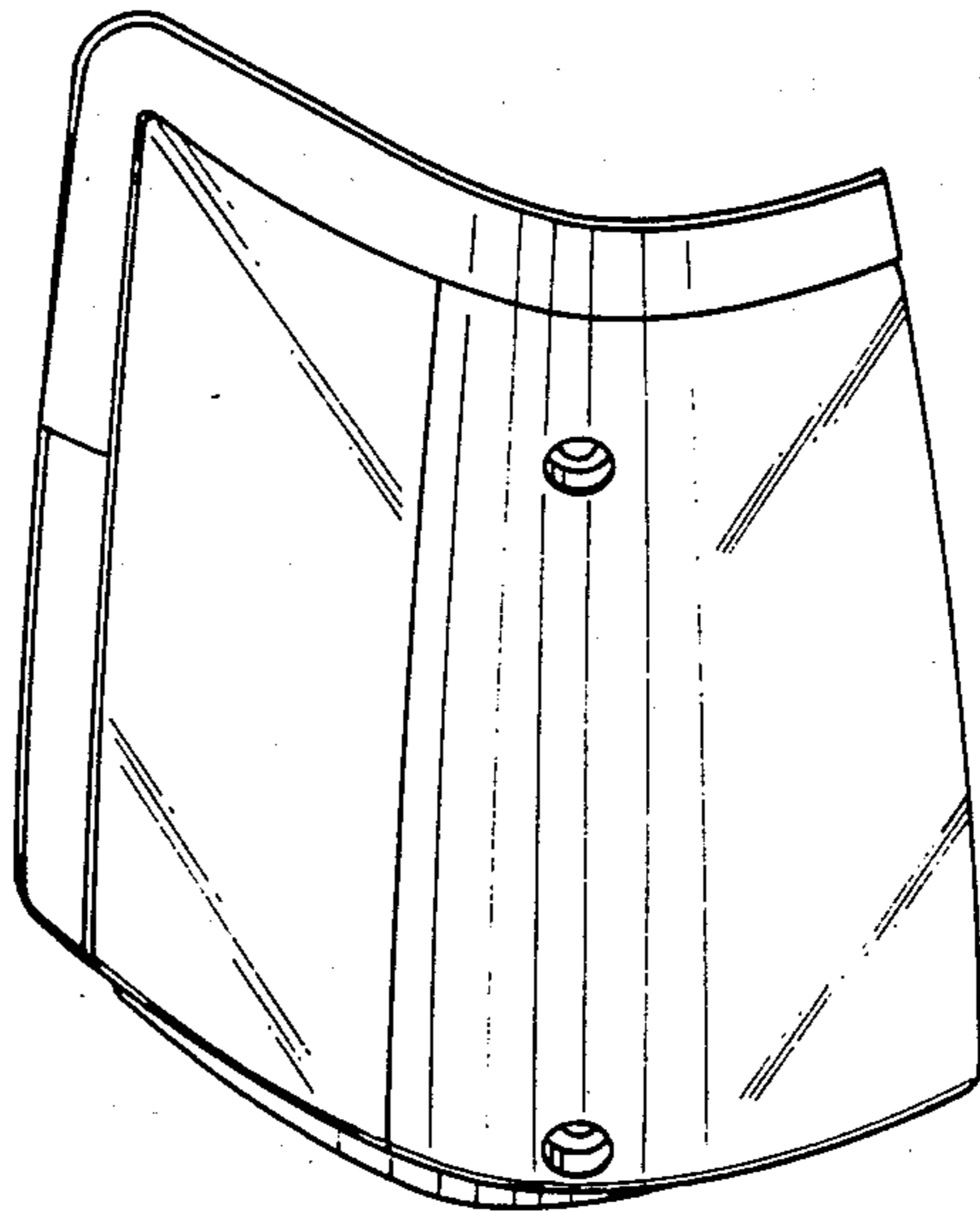

Fig. 2

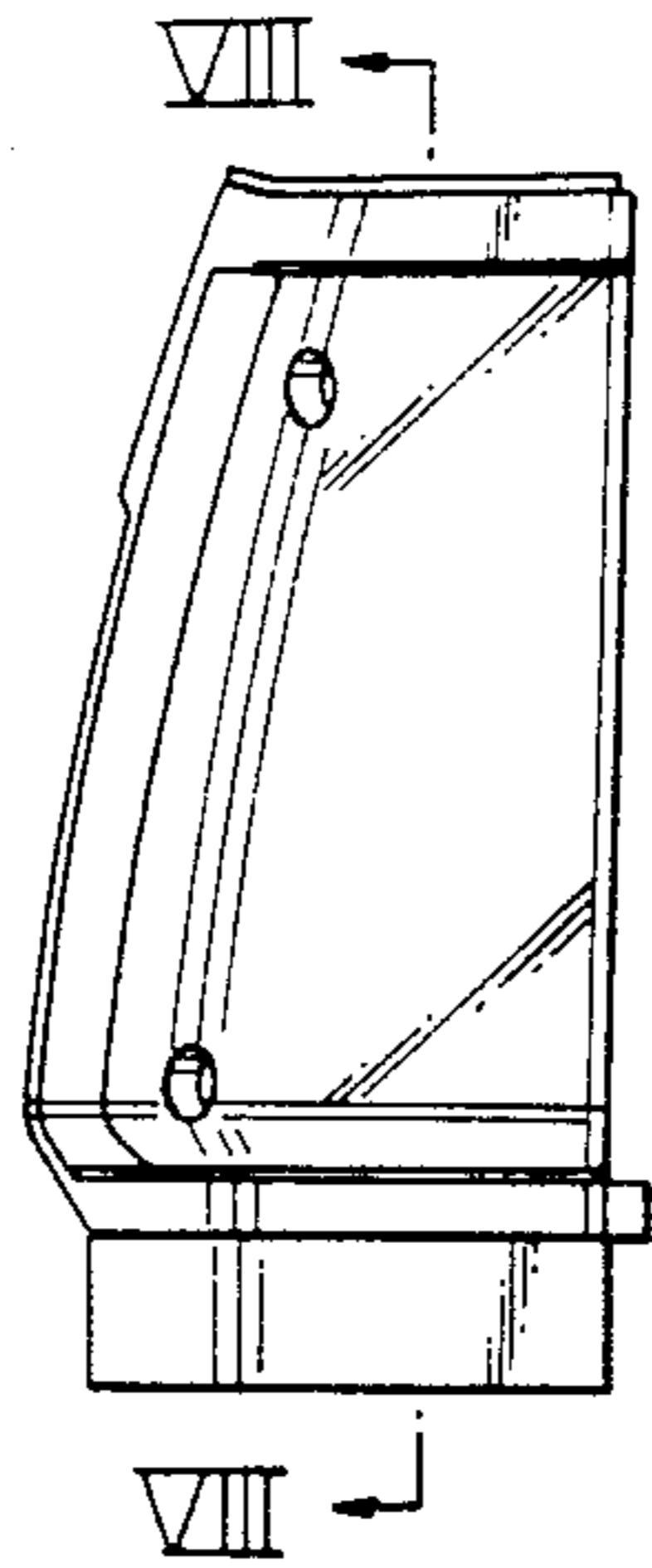

Fig. 3

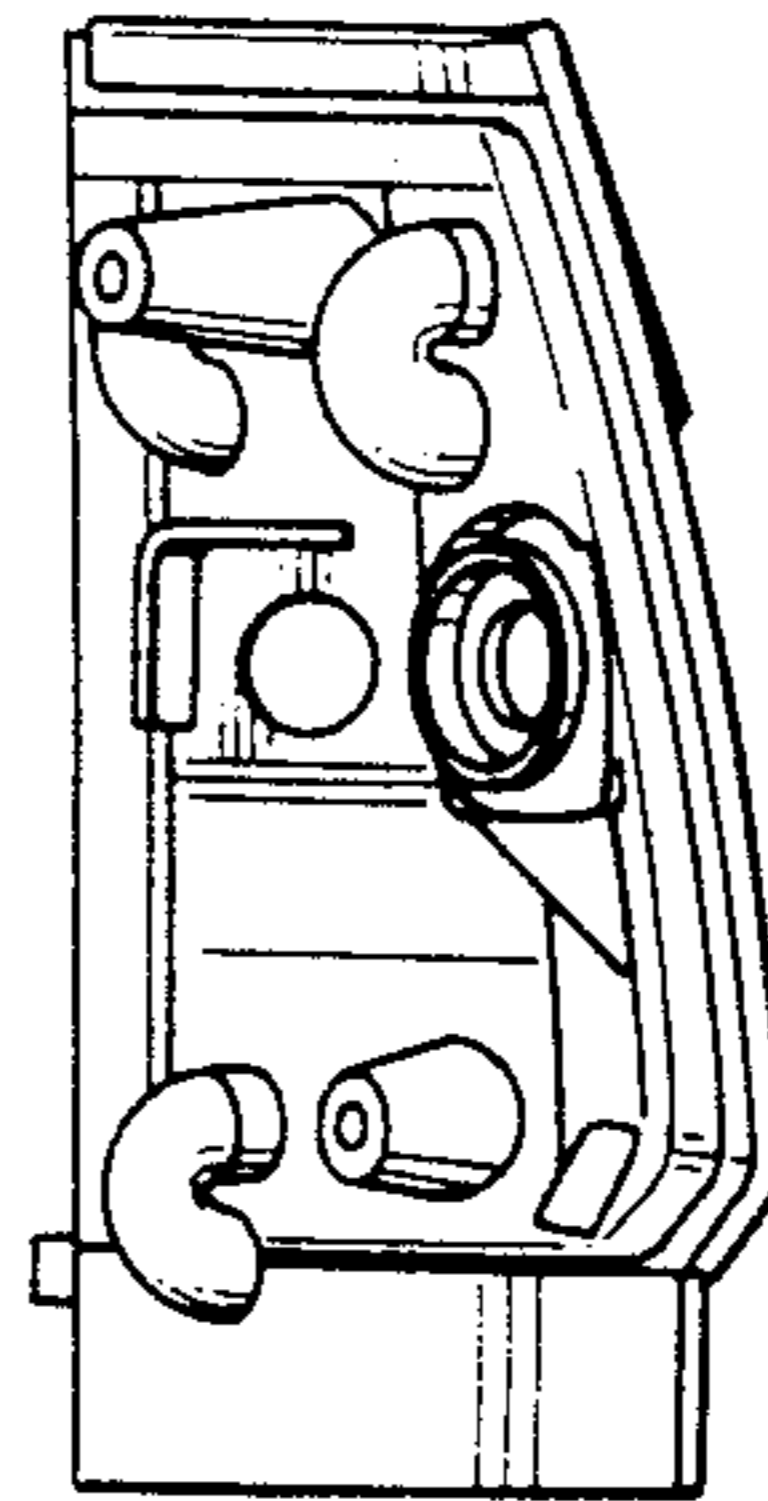

Fig. 4

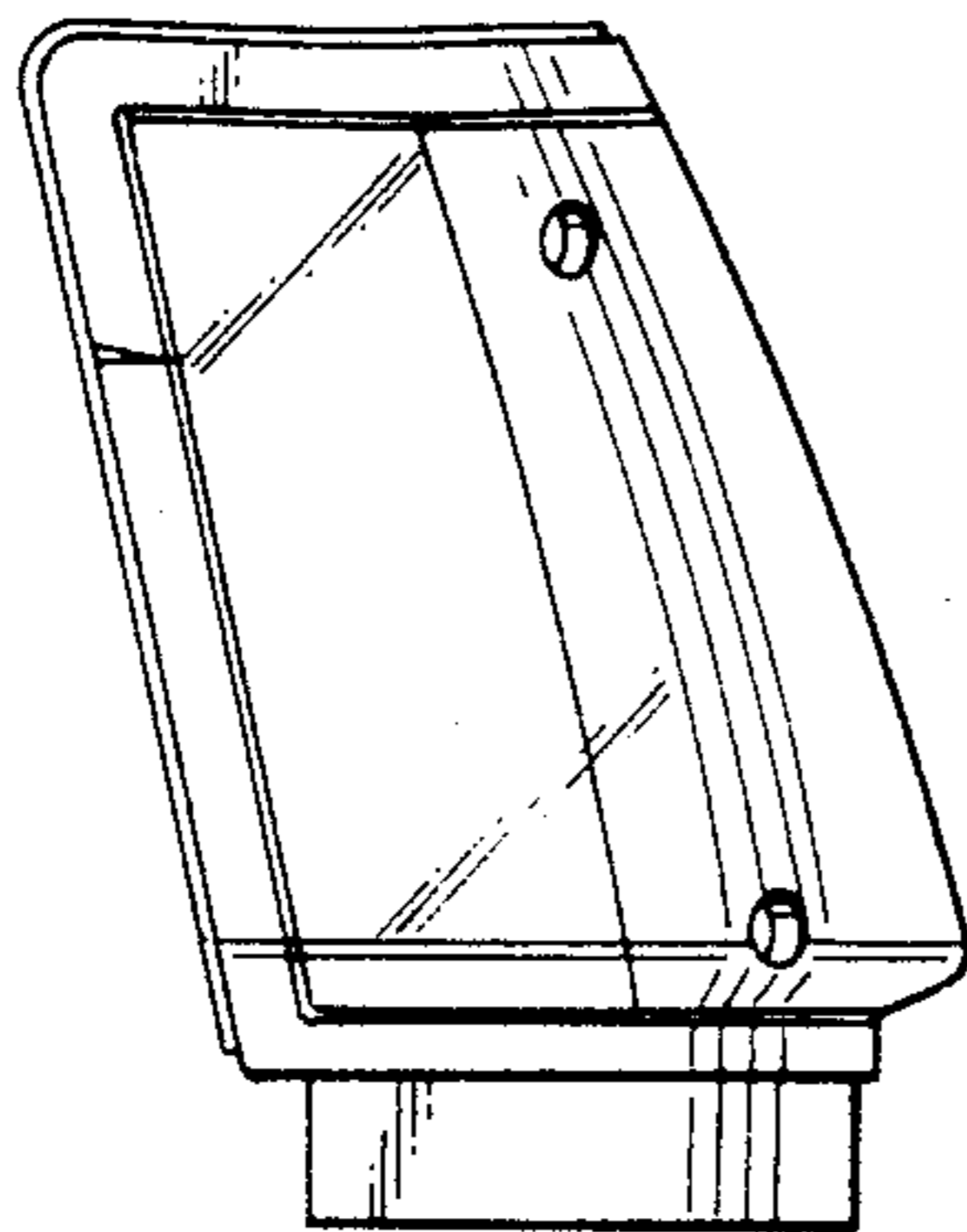

Fig. 5

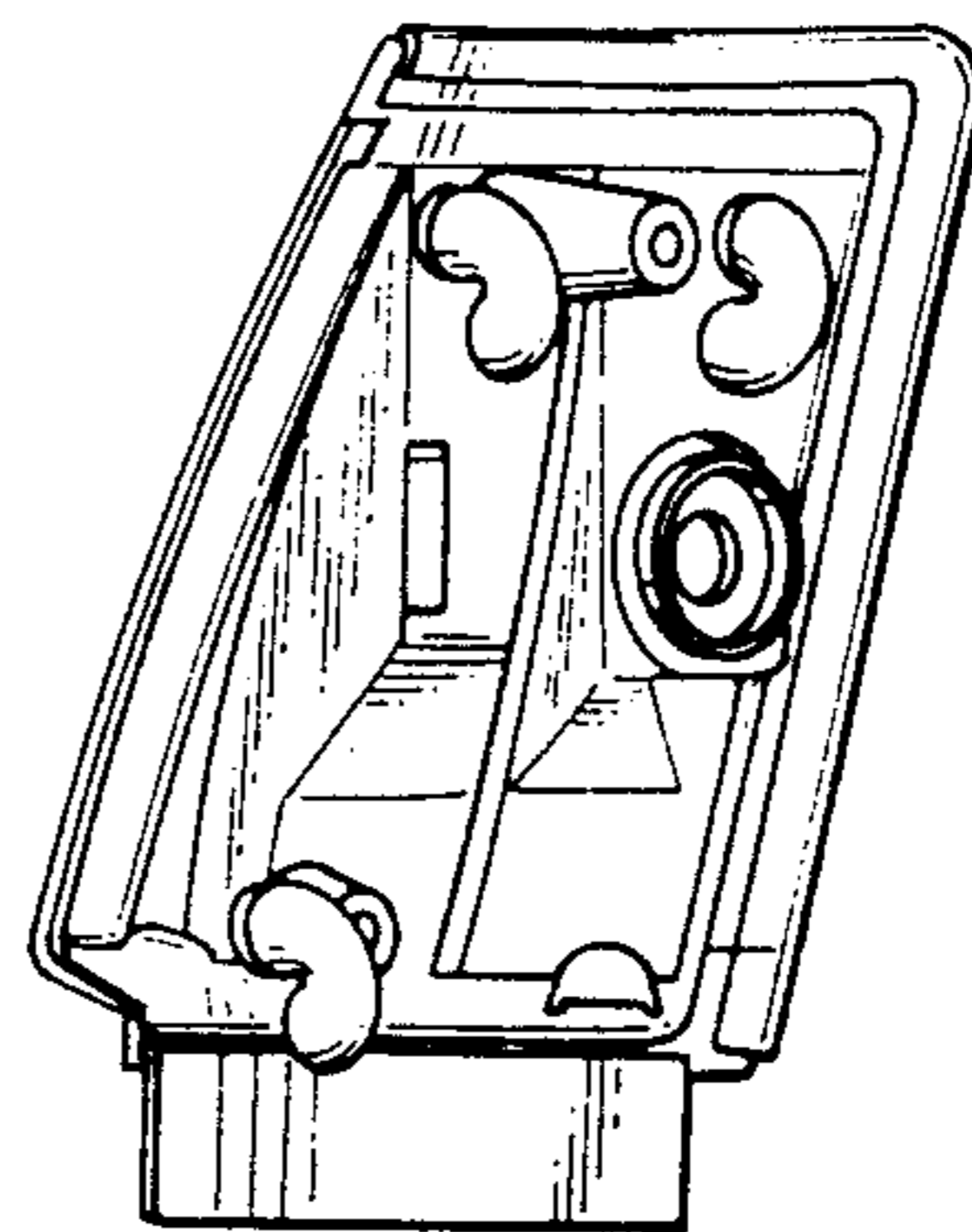

Fig. 6

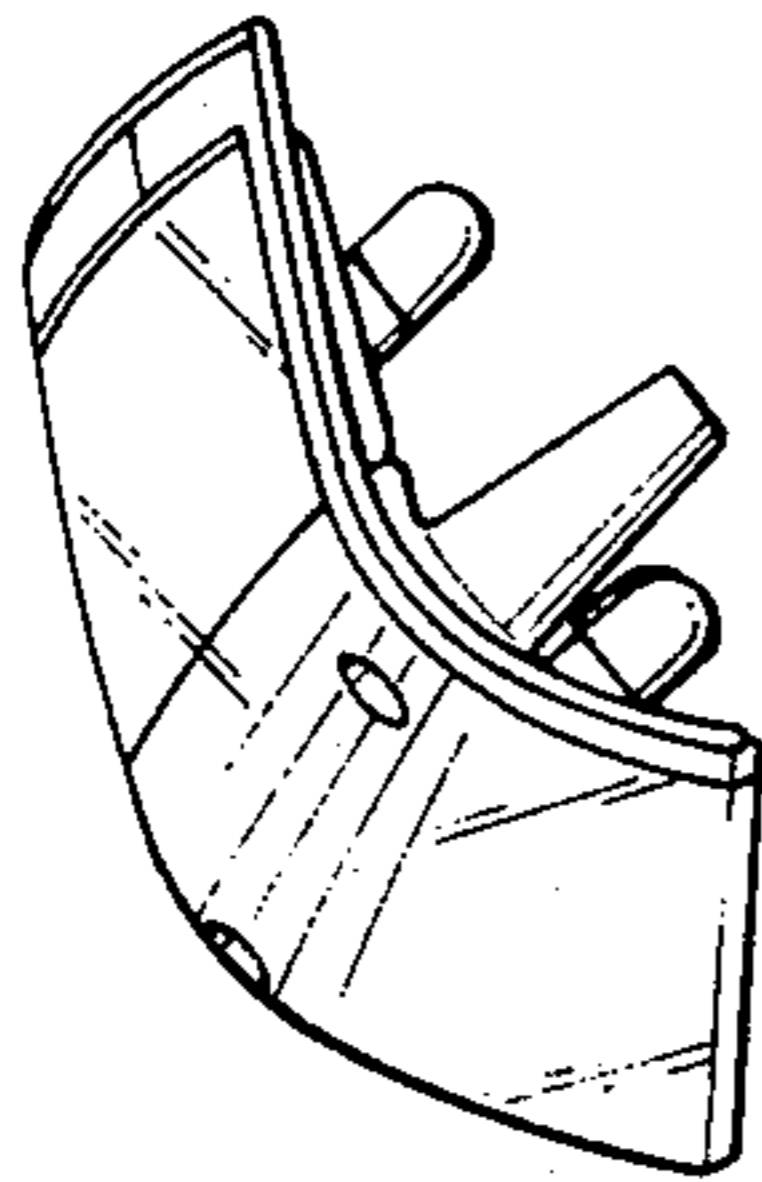

Fig. 7

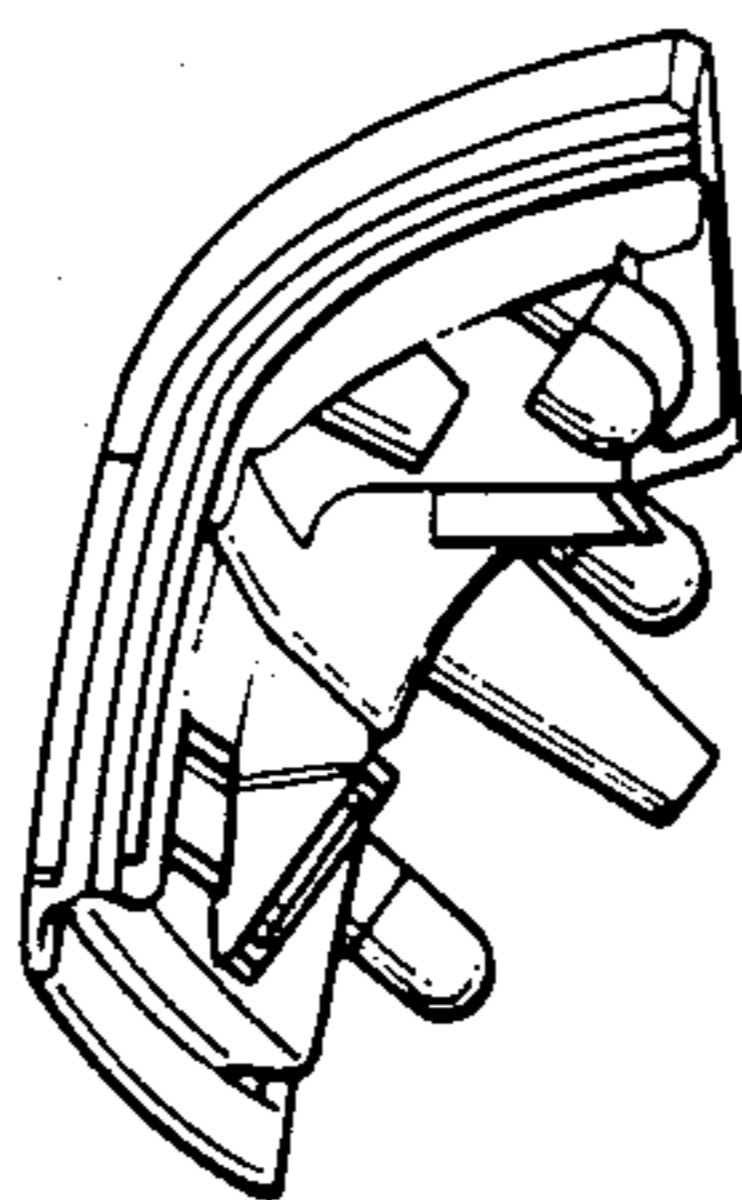

Fig. 8

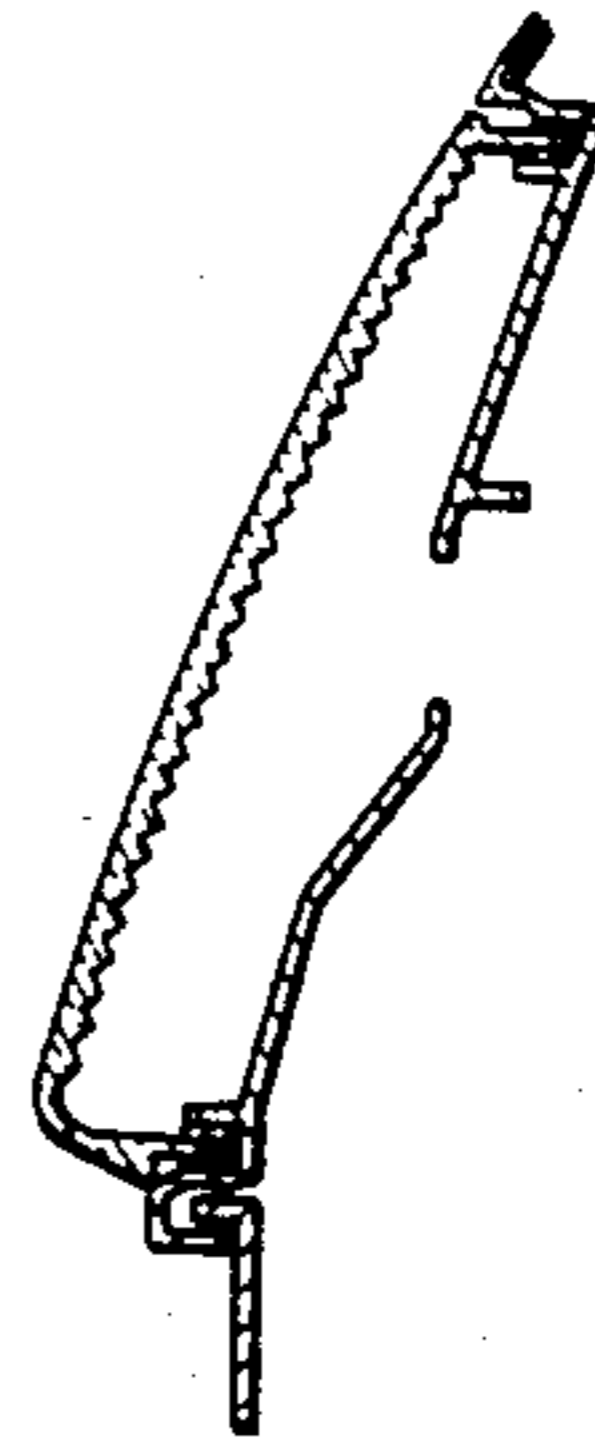

Fig. 9

