

[54] **AIRCRAFT**

[75] **Inventor:** Robert R. Sandusky, Jr., Los Alamitos; Victor C. Brock, Whittier; Lionel O. Gay, Glendale, all of Calif.

[73] **Assignee:** Northrop Corporation, Hawthorne, Calif.

[**] **Term:** 14 Years

[21] **Appl. No.:** 521,222

[22] **Filed:** Aug. 8, 1983

Related U.S. Application Data

[63] Continuation of Ser. No. 186,675, Sep. 12, 1980, abandoned.

[52] **U.S. Cl.** D12/342

[58] **Field of Search** D12/342

[56] **References Cited**

PUBLICATIONS

Jane's All the World's Aircraft, Taylor ed., 1974-1975, p. 408, Northrup F-5E Aircraft at top of page.

Primary Examiner—James M. Gandy
Attorney, Agent, or Firm—Terry J. Anderson; Robert B. Block

[57] **CLAIM**

The ornamental design of an aircraft, as shown and described.

DESCRIPTION

FIG. 1 is a perspective view of an aircraft showing our new design;

FIG. 2 is a top plan view thereof;

FIG. 3 is a front elevation view thereof;

FIG. 4 is a rear elevation view thereof; and

FIG. 5 is a left side elevation view thereof.

The parts shown in broken lines are for illustrative purposes only and form no part of the design.

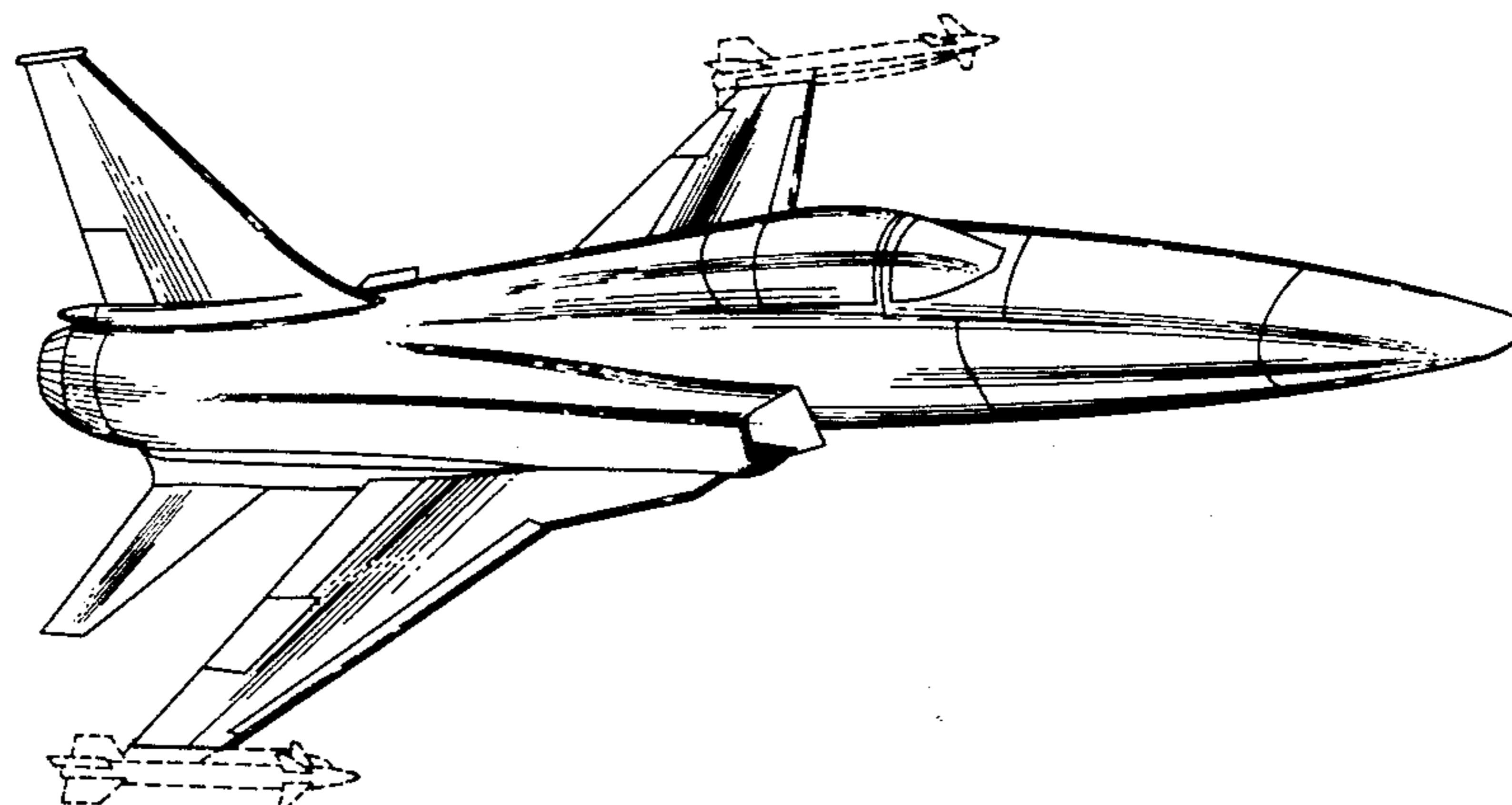

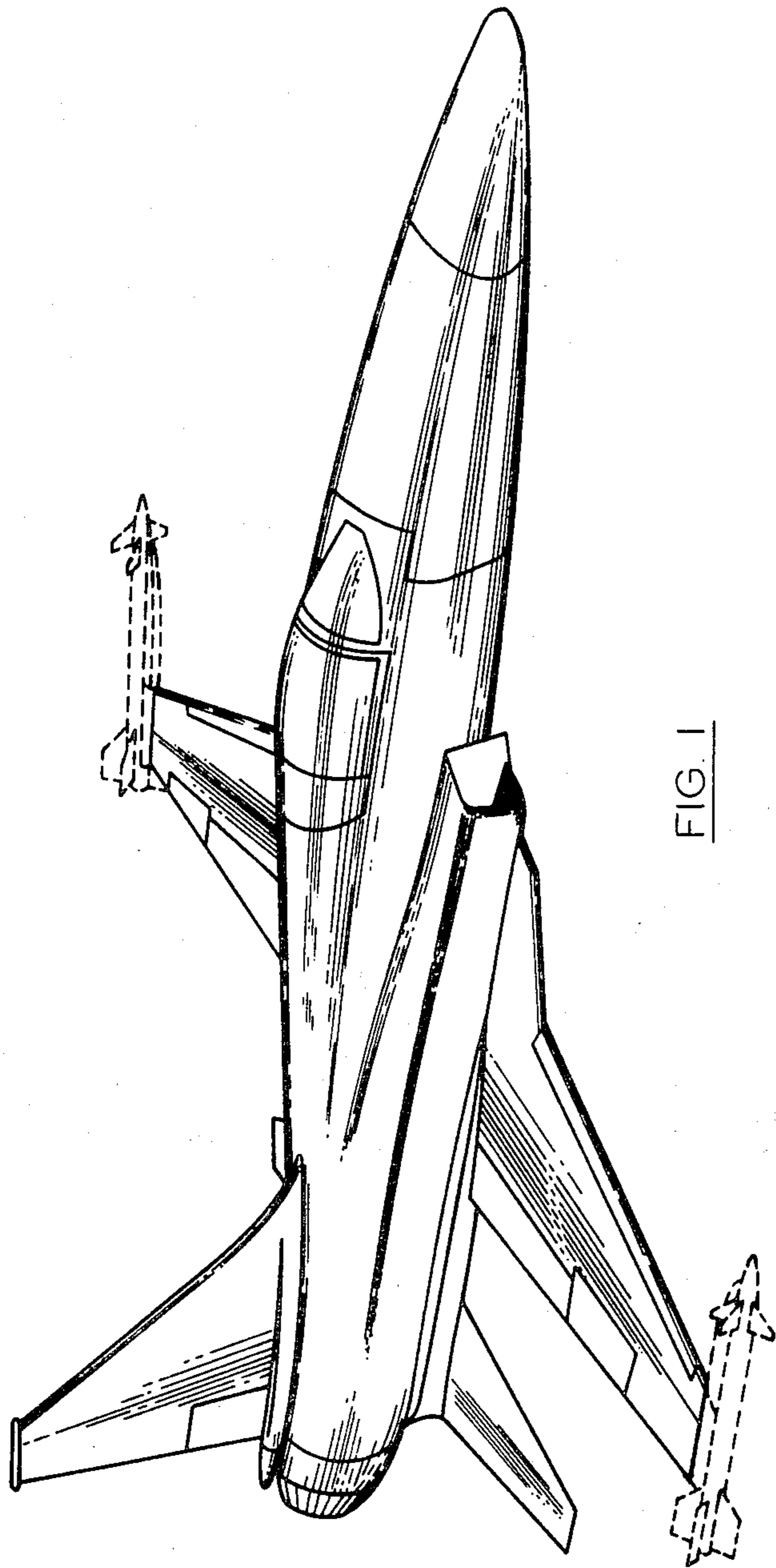

FIG. 1

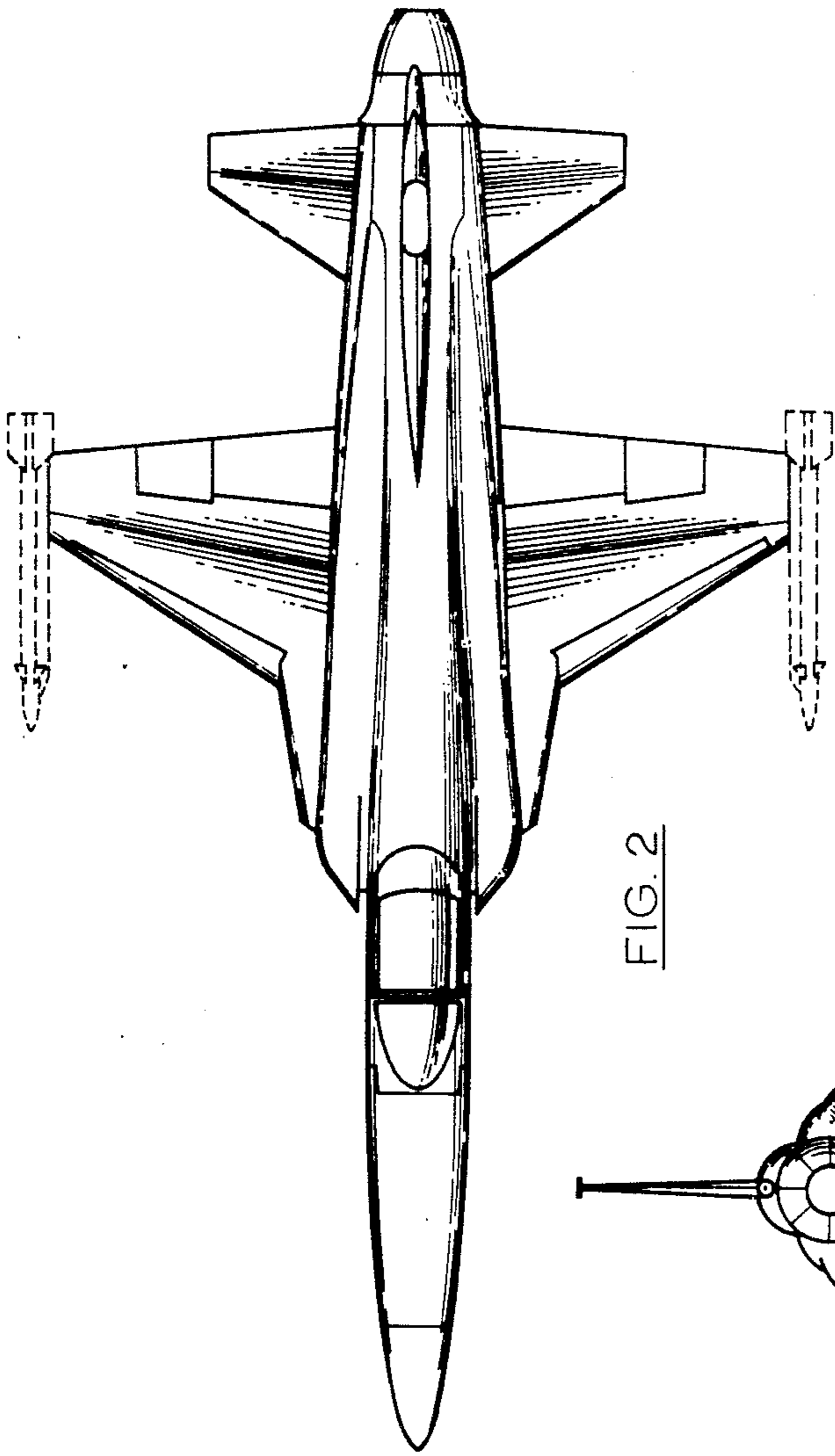

FIG. 2

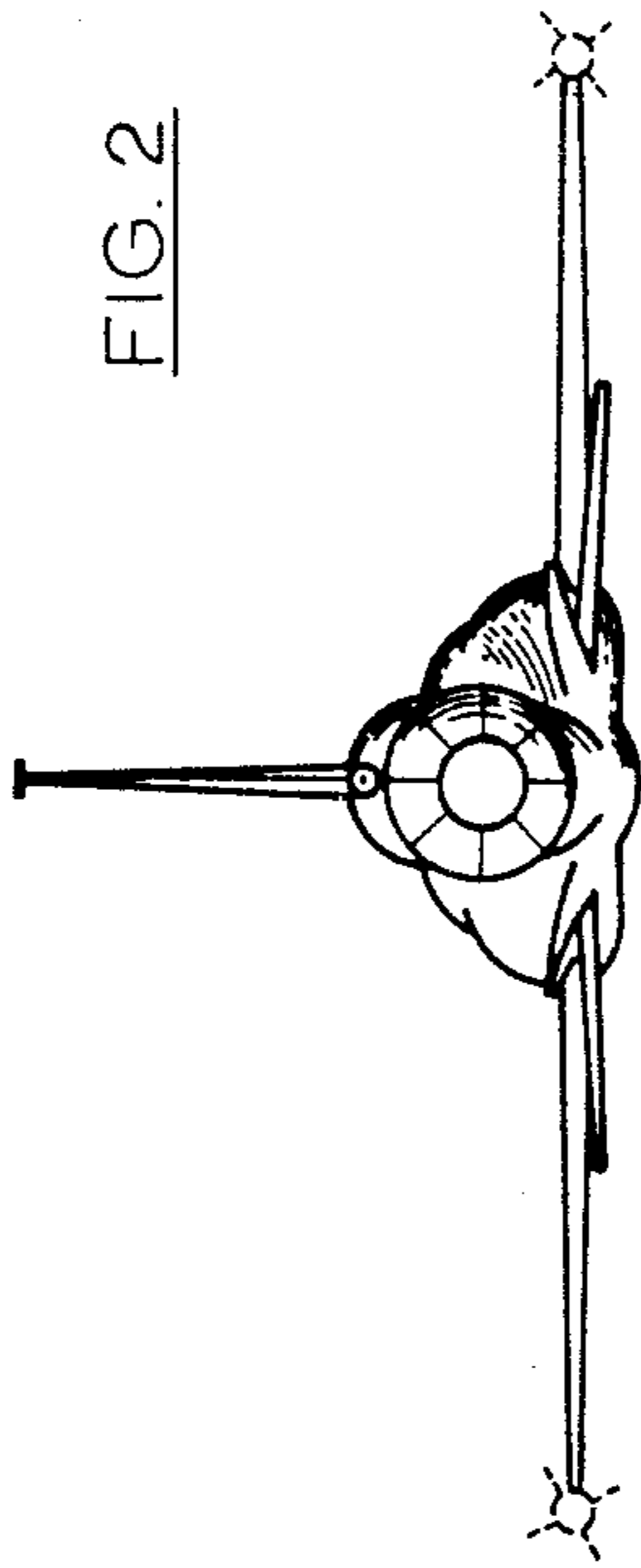

FIG. 4

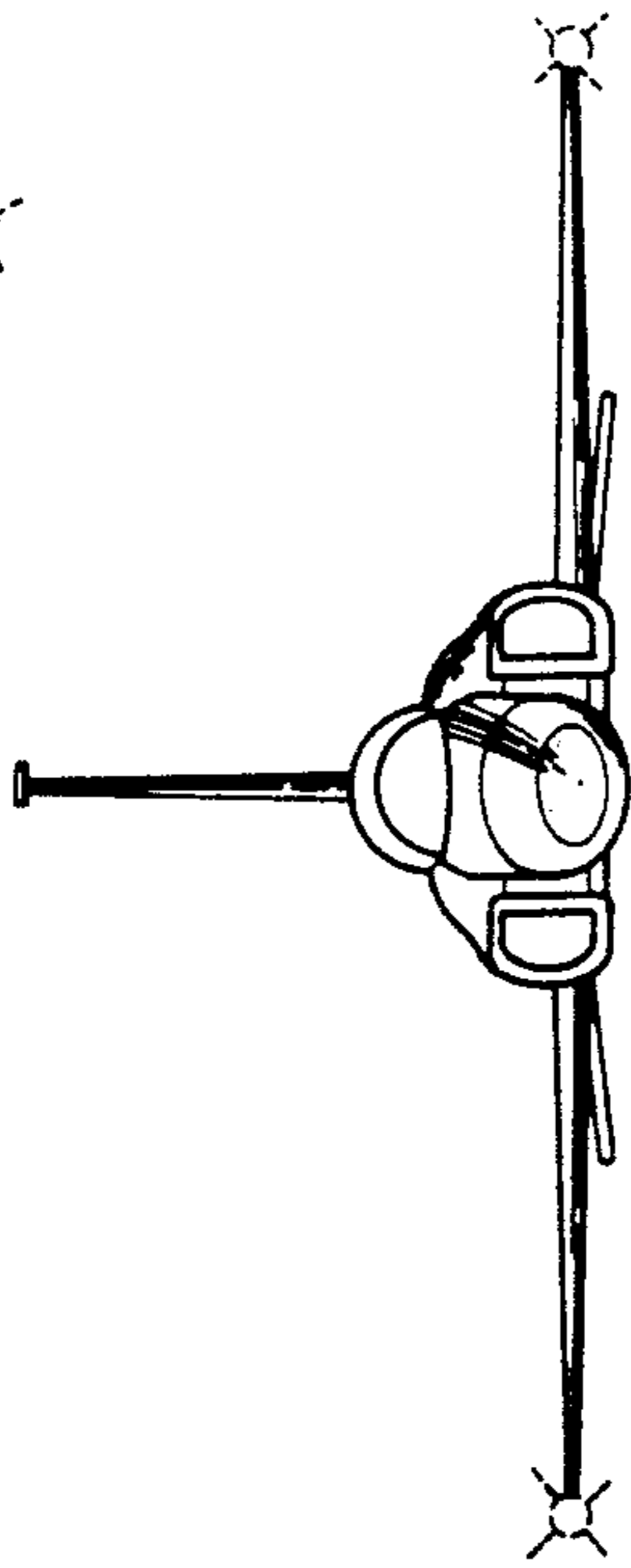

FIG. 3

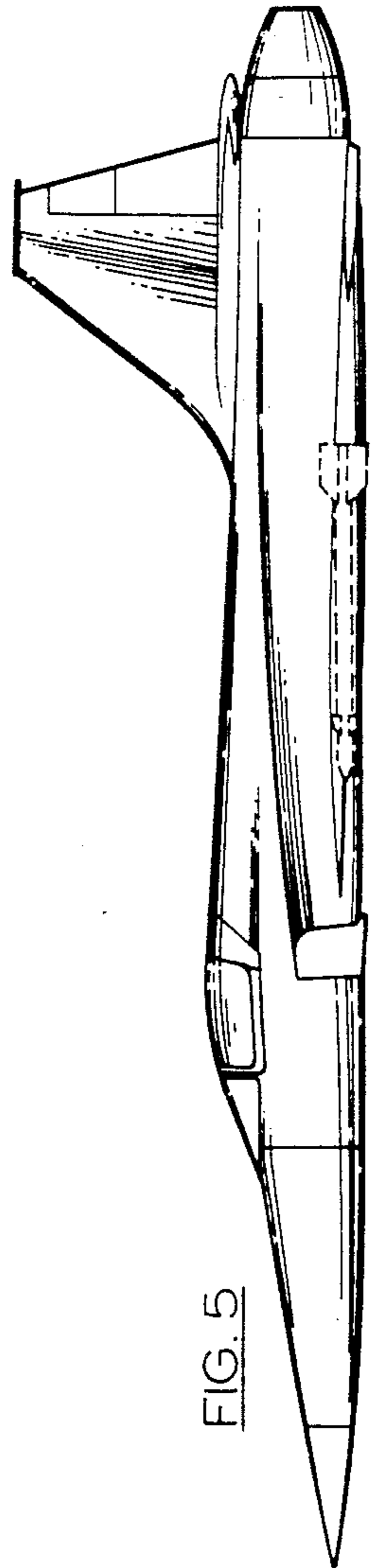

FIG. 5

**UNITED STATES PATENT OFFICE
CERTIFICATE OF CORRECTION**

PATENT NO. :Des. 285,062

DATED :August 12, 1986

INVENTOR(S) :Robert R. Sandusky, Victor C. Brock,
and Lionel O. Gay

It is certified that error appears in the above-identified patent and that said Letters Patent are hereby corrected as shown below: Title page:

line 2 of the heading, change to read

--Sandusky, Jr. et al.--

second column, second line, change to read

--p. 408, Northrop F-5E Aircraft at top of page.--

**Signed and Sealed this
Sixteenth Day of December, 1986**

Attest:

DONALD J. QUIGG

Attesting Officer

Commissioner of Patents and Trademarks