

United States Patent [19] Taylor

[11] Patent Number: Des. 284,694

[45] Date of Patent: ** Jul. 15, 1986

[54] EVAPORATOR FOR AN AUTOMOTIVE AIR CONDITIONER

[76] Inventor: Shelton E. Taylor, 4112 Oakellar, Tampa, Fla. 33611

[**] Term: 14 Years

[21] Appl. No.: 622,211

[22] Filed: Jun. 19, 1984

Primary Examiner—Wallace R. Burke
Assistant Examiner—Brian N. Vinson
Attorney, Agent, or Firm—Stein, Reese & Prescott

[57] CLAIM

The ornamental design for an evaporator for an automotive air conditioner, as shown and described.

DESCRIPTION

FIG. 1 is a front elevational view of an evaporator for an automotive air conditioner showing the first embodiment of my new design;
FIG. 2 is a right side view thereof;
FIG. 3 is a left side view thereof;
FIG. 4 is a top view thereof;
FIG. 5 is a bottom view thereof;
FIG. 6 is a rear view thereof;
FIG. 7 is a front elevational view of an evaporator for an automotive air condition showing the second embodiment of my new design;
FIG. 8 is a right side view thereof;
FIG. 9 is a left side view thereof;
FIG. 10 is a top view thereof;
FIG. 11 is a bottom view thereof; and,
FIG. 12 is a rear view thereof.

The radiator fins are partially shown in the views for convenience of illustration only and are understood to cover the entire area of the heat exchange tubing, as indicated by the broken edge lines.

Related U.S. Application Data

[63] Continuation-in-part of Ser. No. 342,597, Jan. 25, 1982, and a continuation-in-part of Ser. No. 552,927, Nov. 18, 1983.

[52] U.S. Cl. D23/163; 62/516

[58] Field of Search D23/139-149, D23/163, 167, 116, 141-142; 98/12, 17; 62/515-523; 165/42, 58-60, 108, 151; 261/DIG. 43, 3

[56] References Cited

U.S. PATENT DOCUMENTS

3,030,782	4/1962	Karmazin	62/516
3,080,916	3/1963	Collins	165/151
4,114,397	9/1978	Takahashi et al.	62/516
4,172,496	10/1979	Melnyk	165/151
4,244,194	1/1981	Haesters et al.	62/515
4,430,868	2/1984	Kern et al.	62/515
4,446,915	5/1984	Welch et al.	165/151

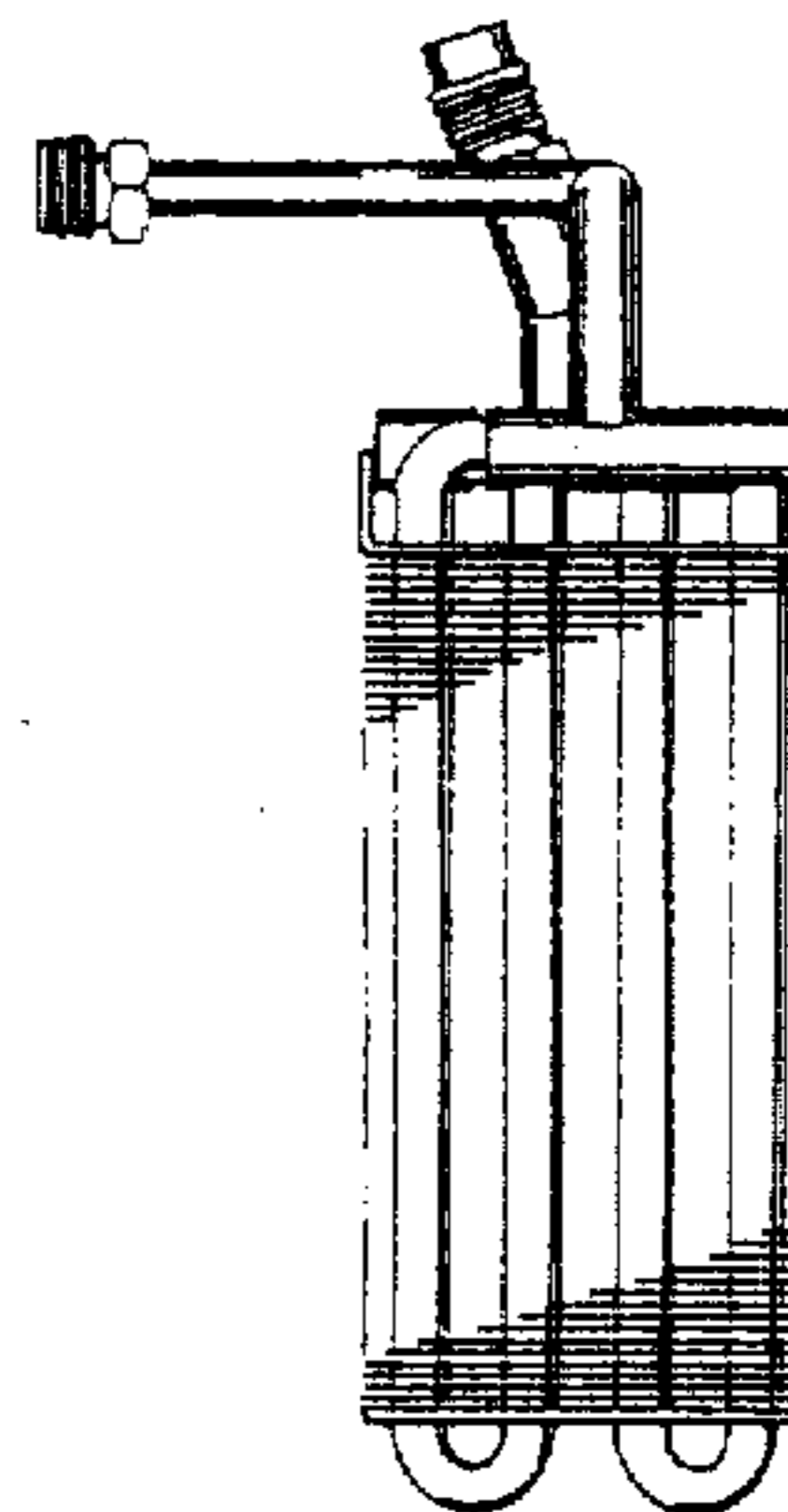
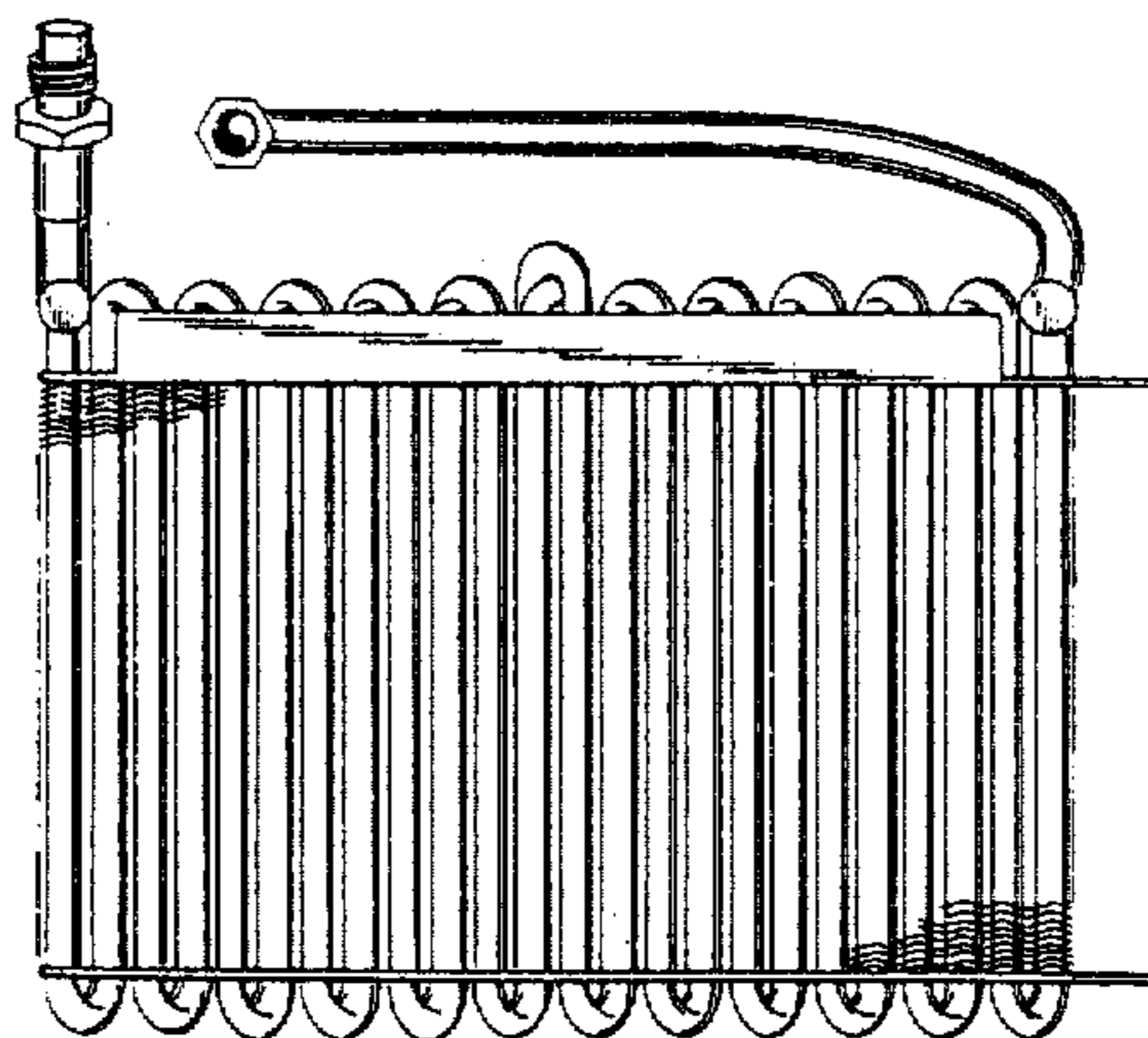

Fig. 2

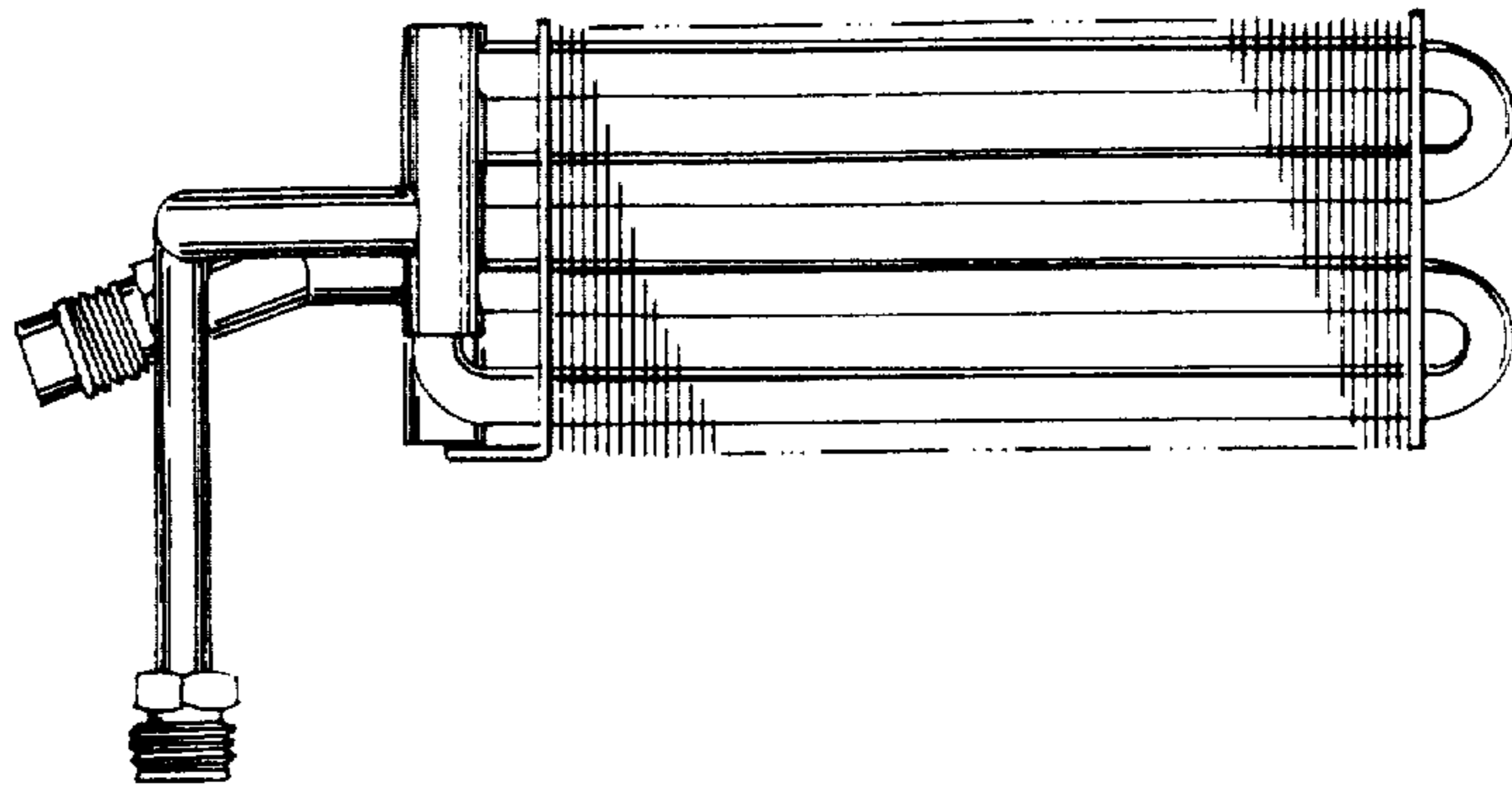

Fig. 1

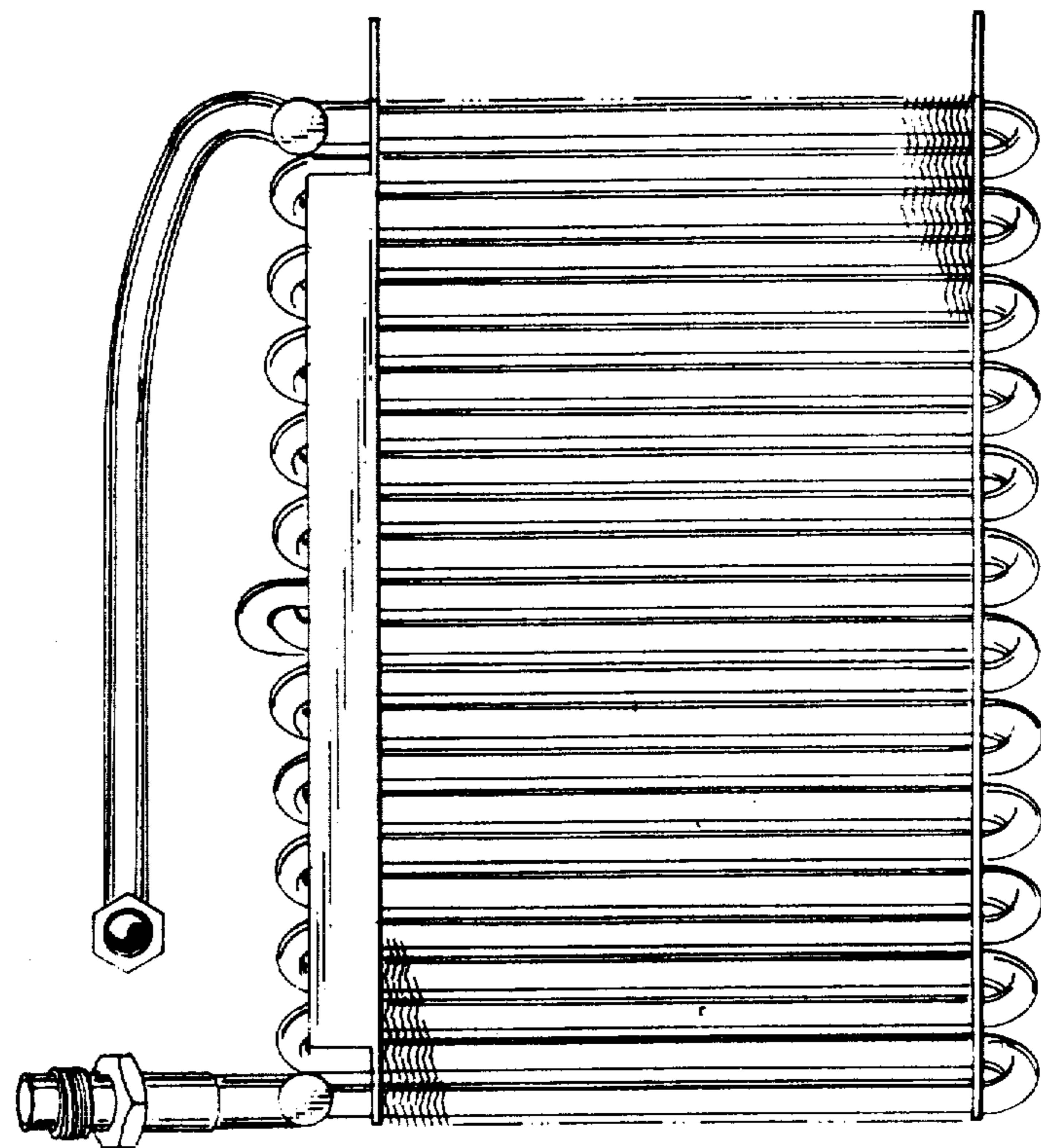

Fig. 3

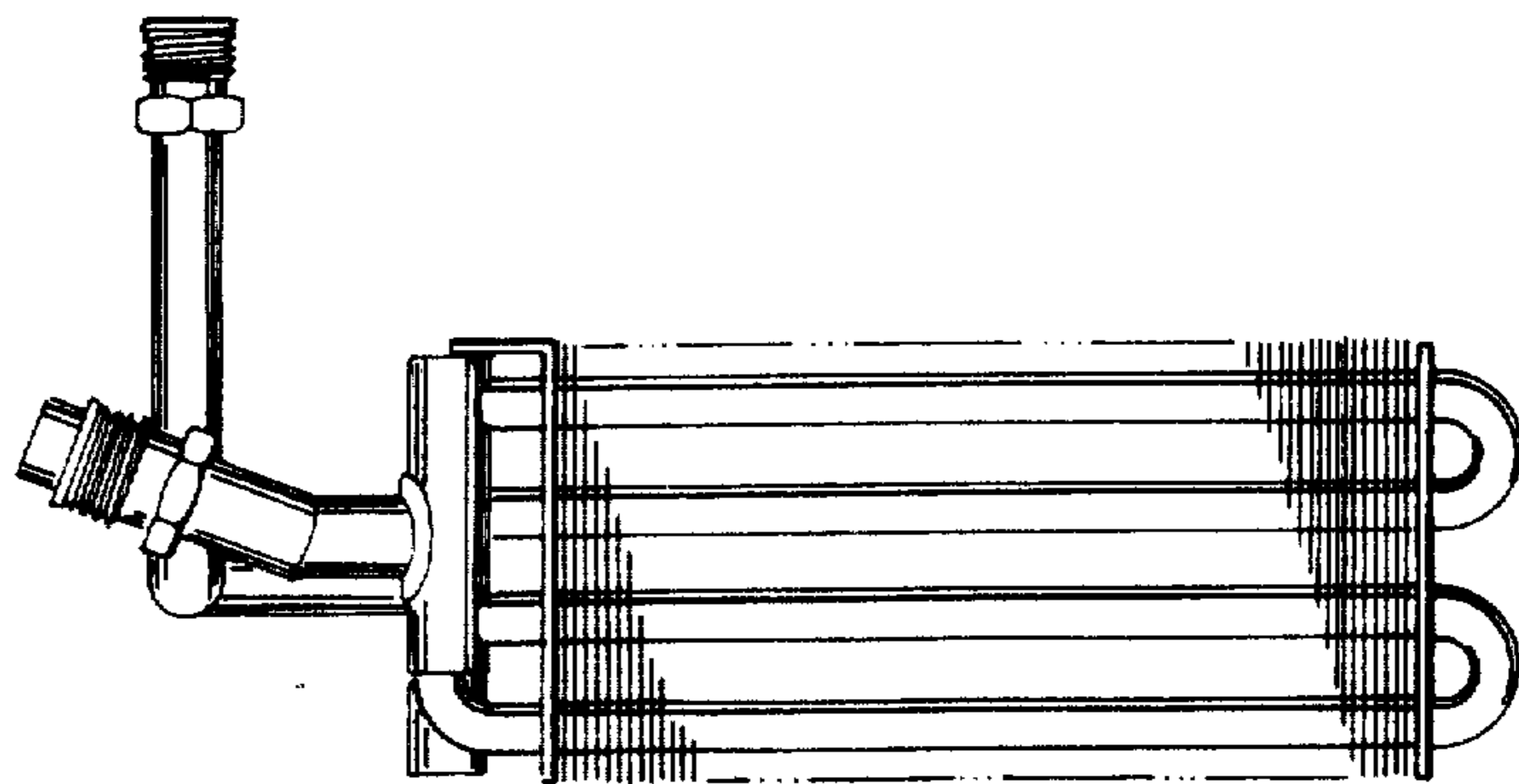

Fig. 4

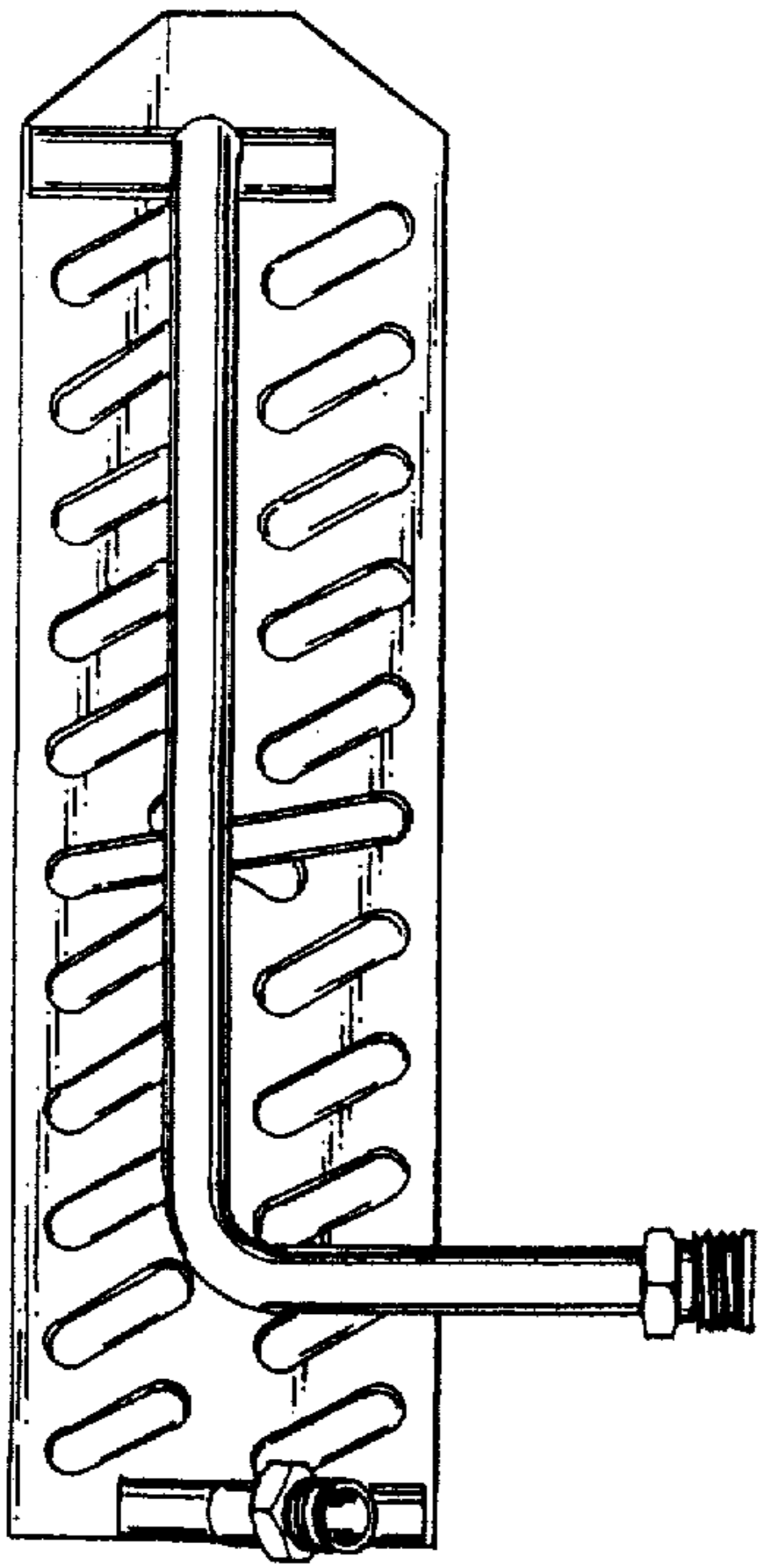

Fig. 5

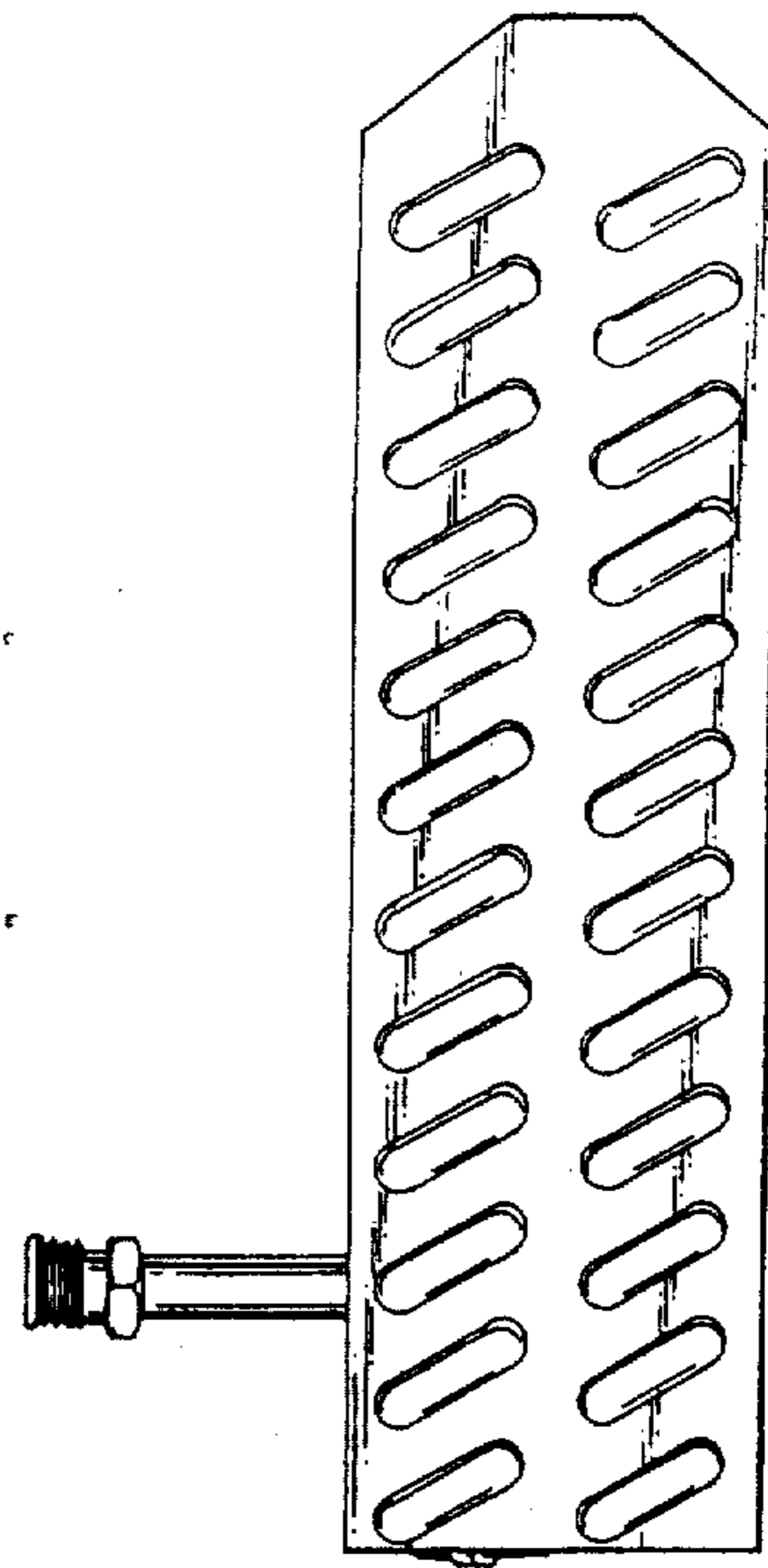

Fig. 6

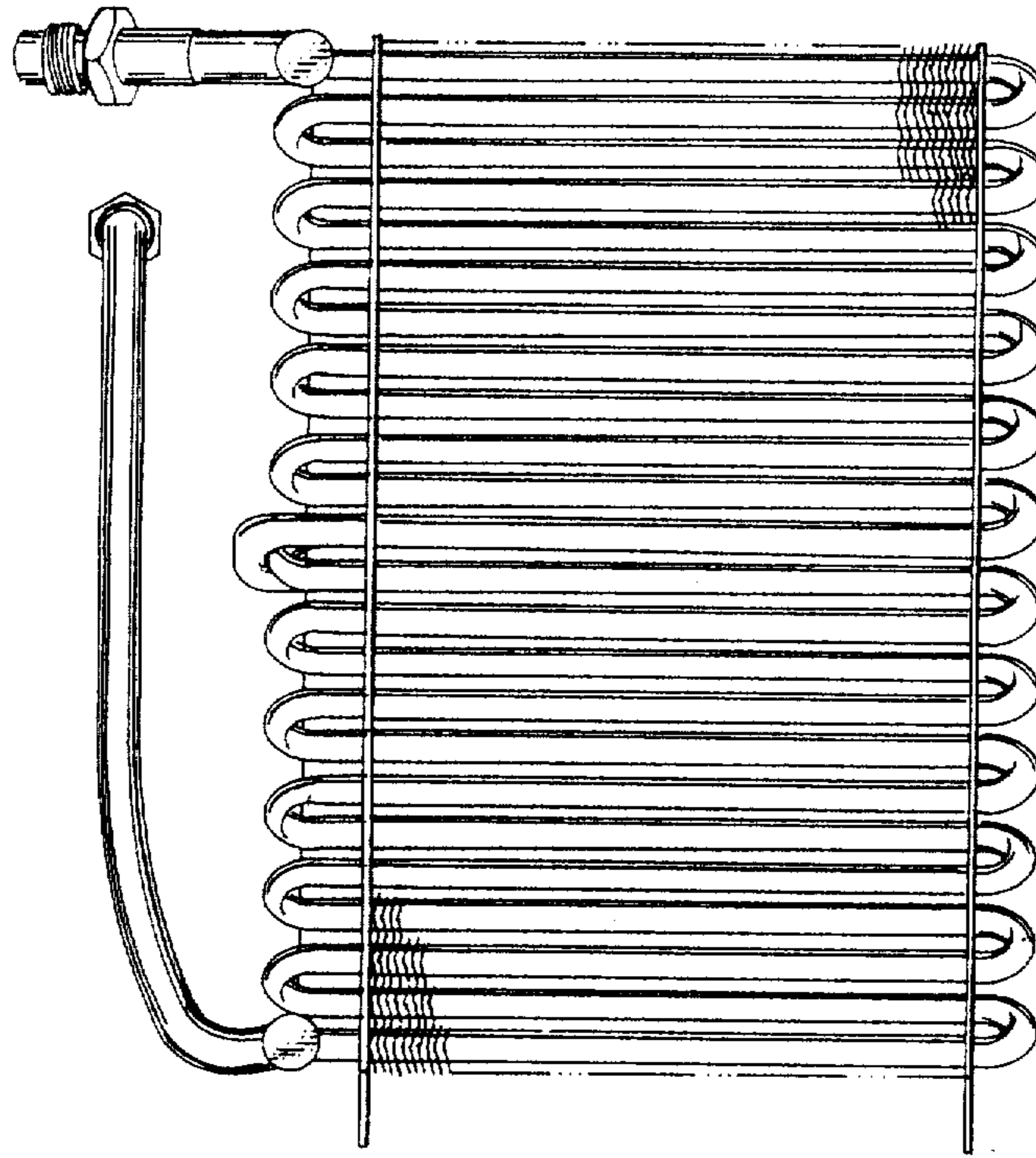

Fig. 8

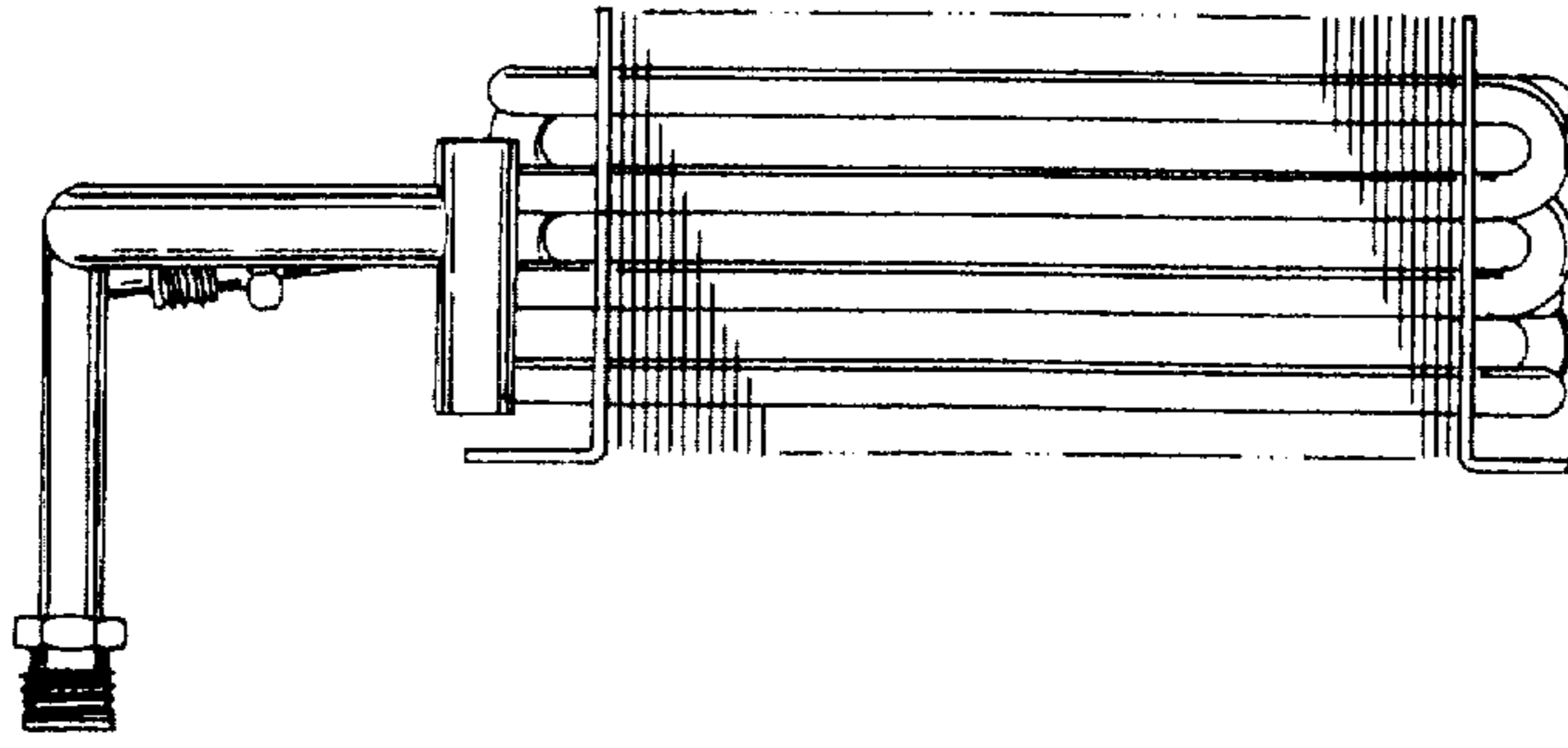

Fig. 7

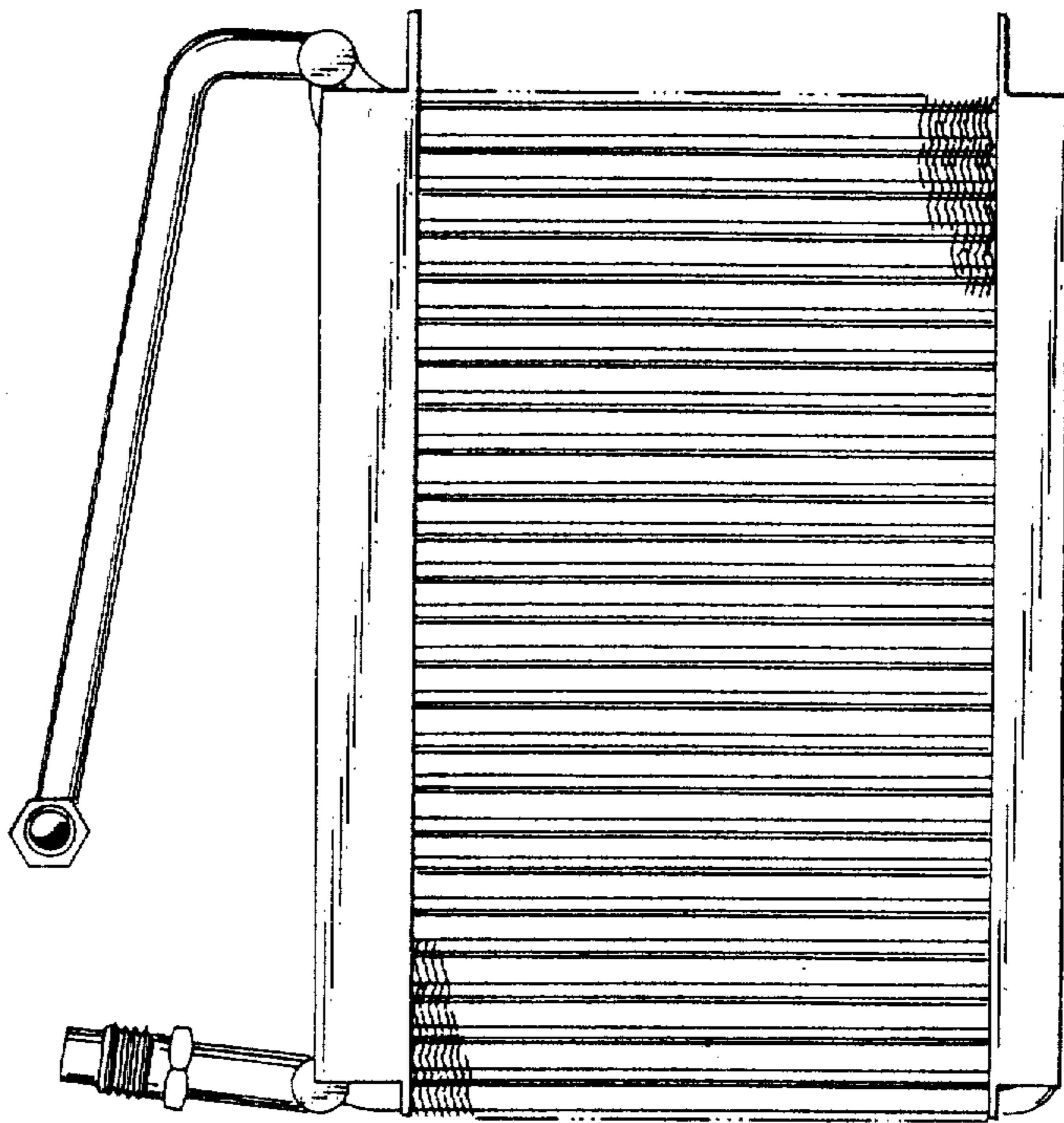

Fig. 9

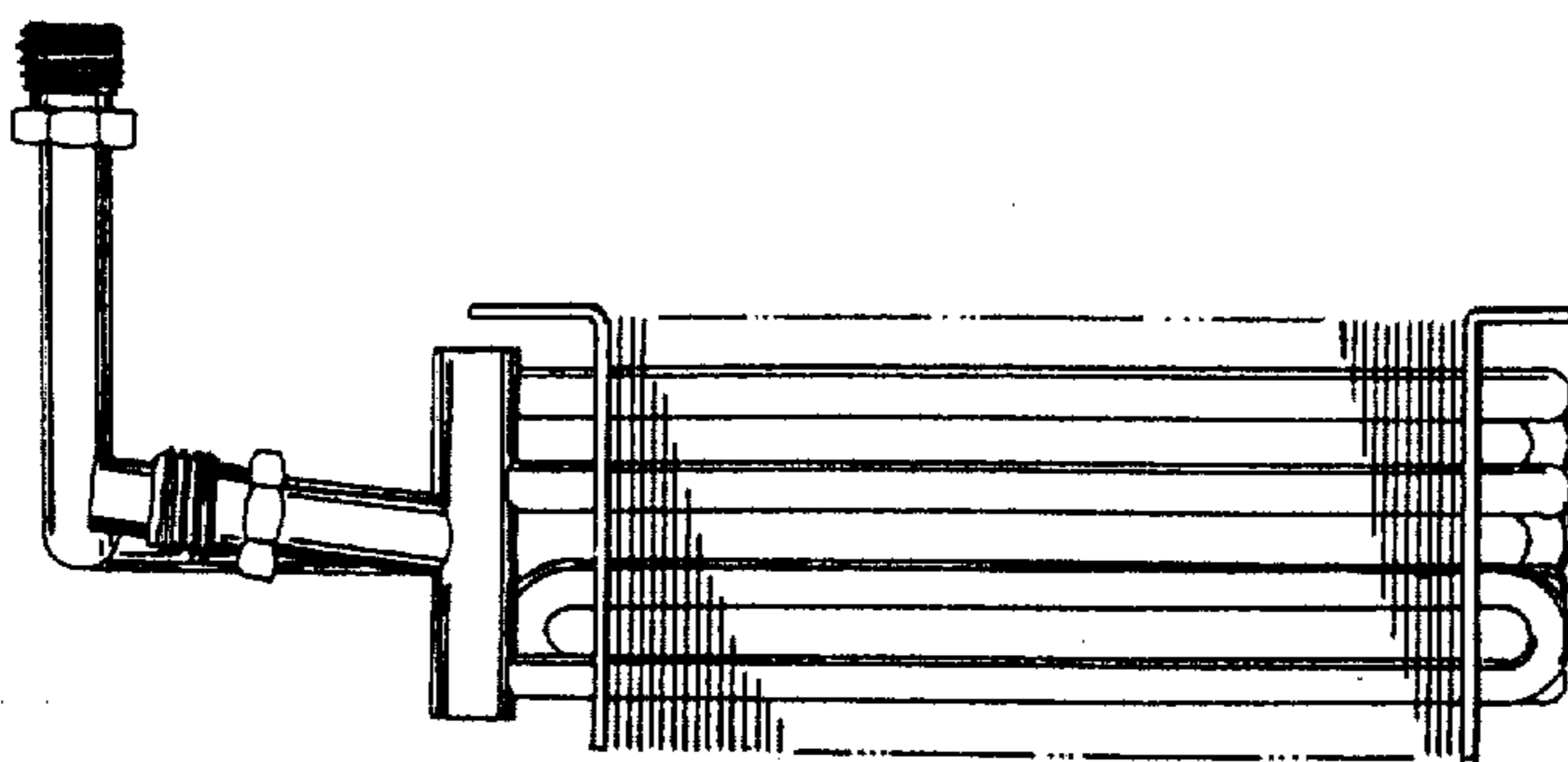

Fig. 12

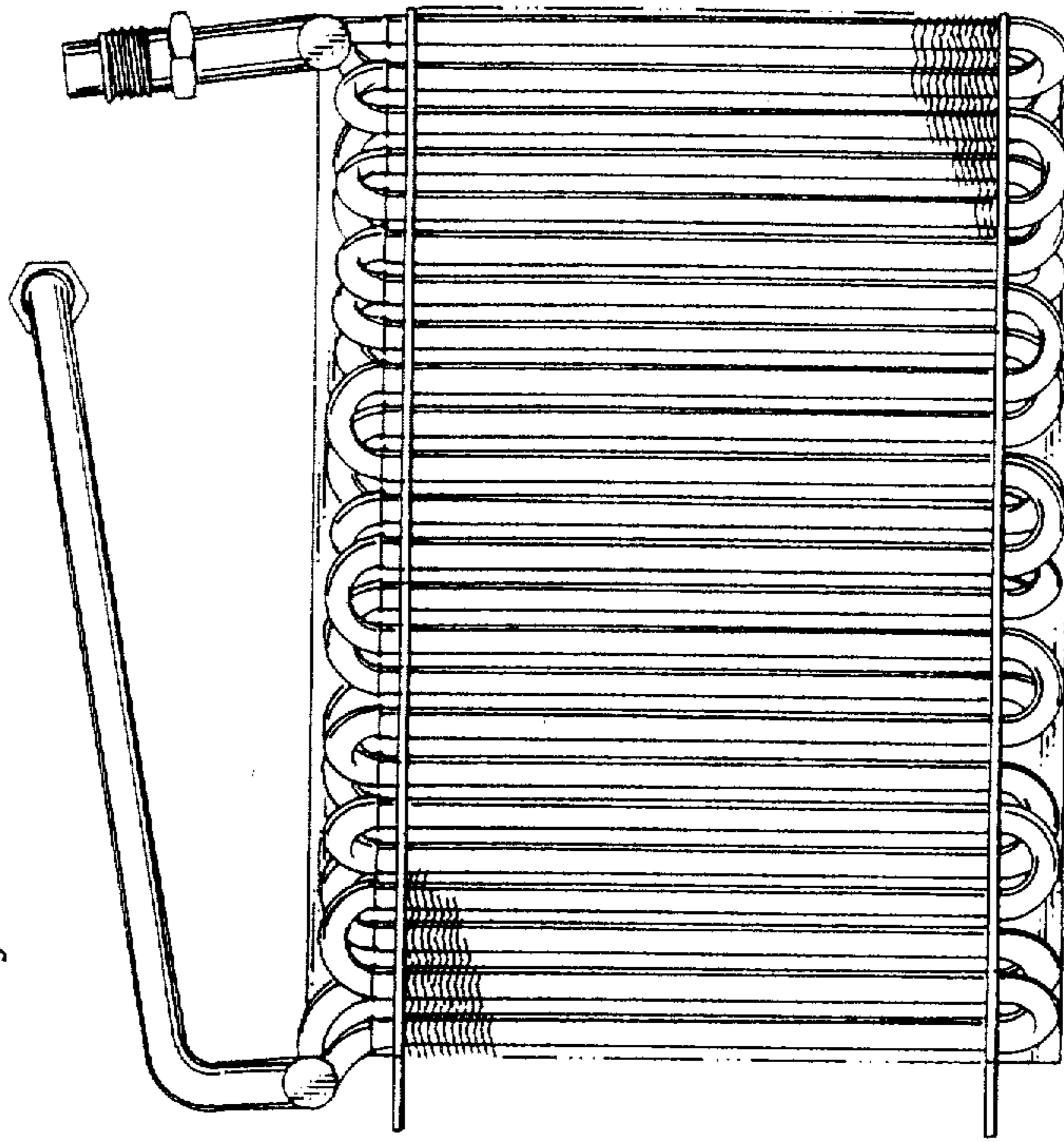

Fig. 10

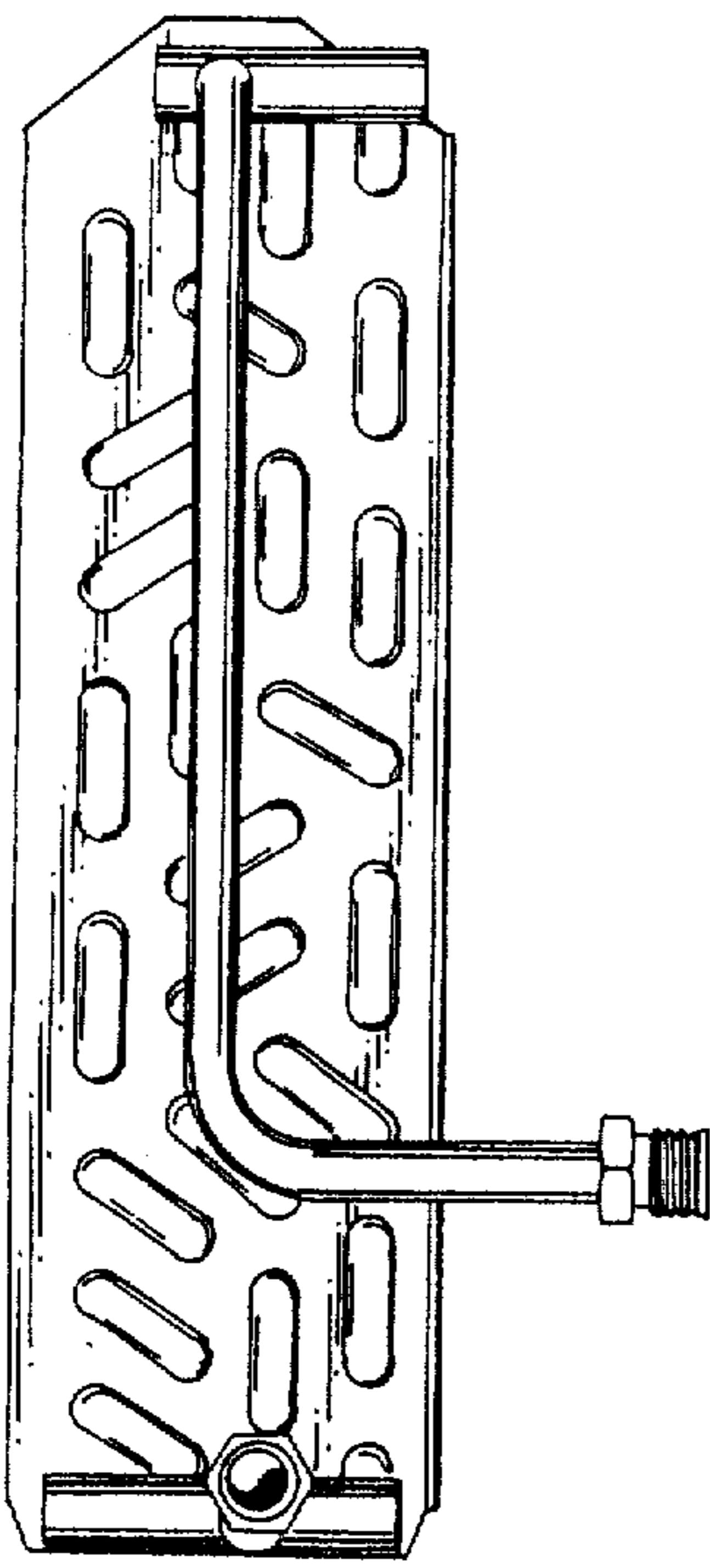

Fig. 11

