

[54] **RETAIL STORE ADVERTISING DISPLAY**

[75] **Inventor: William V. Silver, New York, N.Y.**

[73] **Assignee: Thomson-Leeds Company, Inc., New York, N.Y.**

[**] **Term: 14 Years**

[21] **Appl. No.: 488,121**

[22] **Filed: Apr. 25, 1983**

[52] **U.S. Cl. D20/42**

[58] **Field of Search 40/584, 606, 607, 611, 40/617, 618, 585, 605, 615, 616, 619; D20/10, 12, 15, 18, 19, 40, 42**

[56]

References Cited

U.S. PATENT DOCUMENTS

D. 268,350	3/1983	Cobb	D20/10
D. 270,074	8/1983	Read	D20/42
1,102,145	6/1914	Davis	40/611
1,320,270	10/1919	Phelps	40/611

Primary Examiner—Catherine E. Kemper
Attorney, Agent, or Firm—Howard C. Miskin

[57]

CLAIM

The ornamental design for retail store advertising display, as shown and described.

DESCRIPTION

FIG. 1 is a front perspective view of a retail store advertising display, showing my new design;
FIG. 2 is a rear perspective view thereof;
FIG. 3 is a rear perspective view thereof, shown with the upper panel opened.

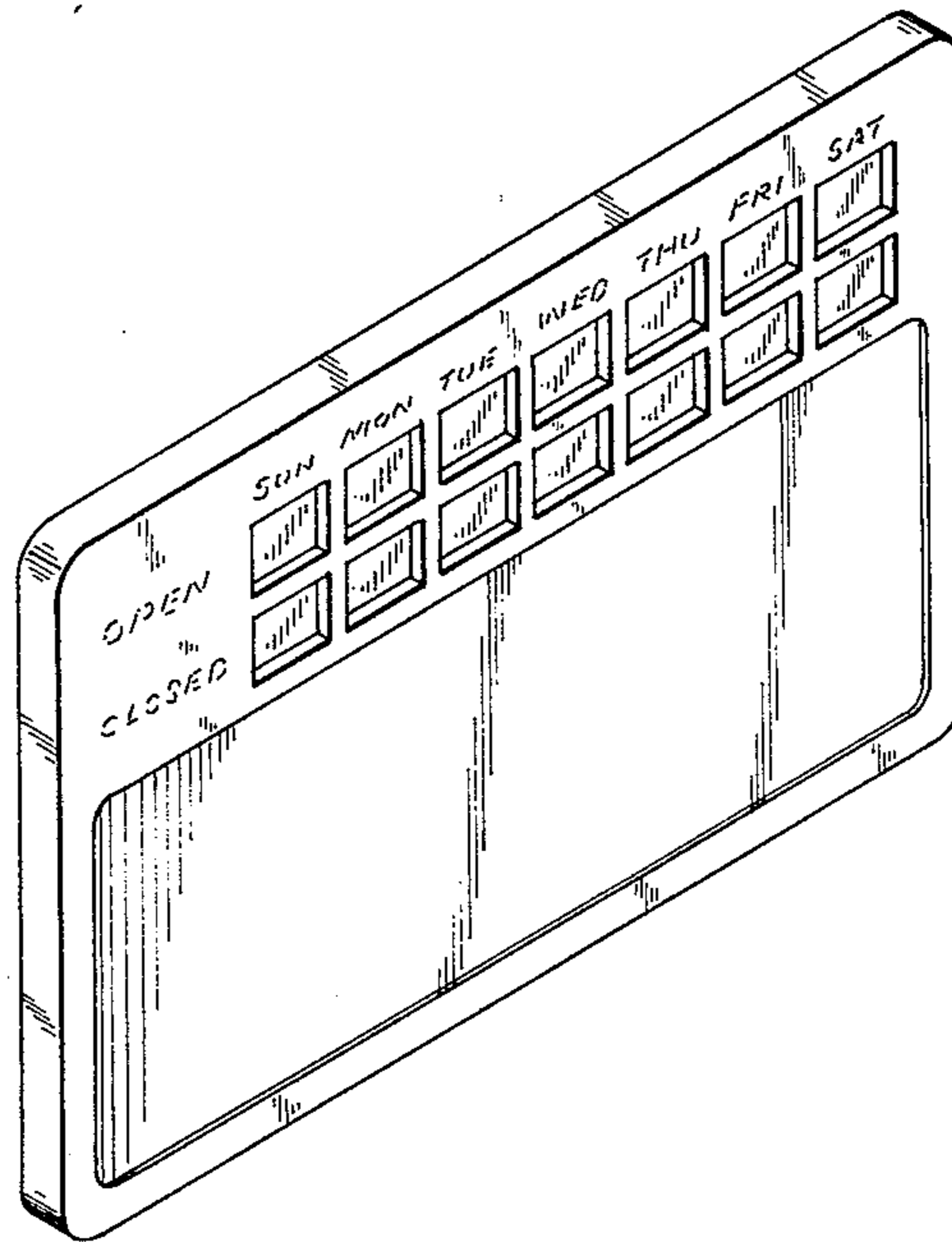

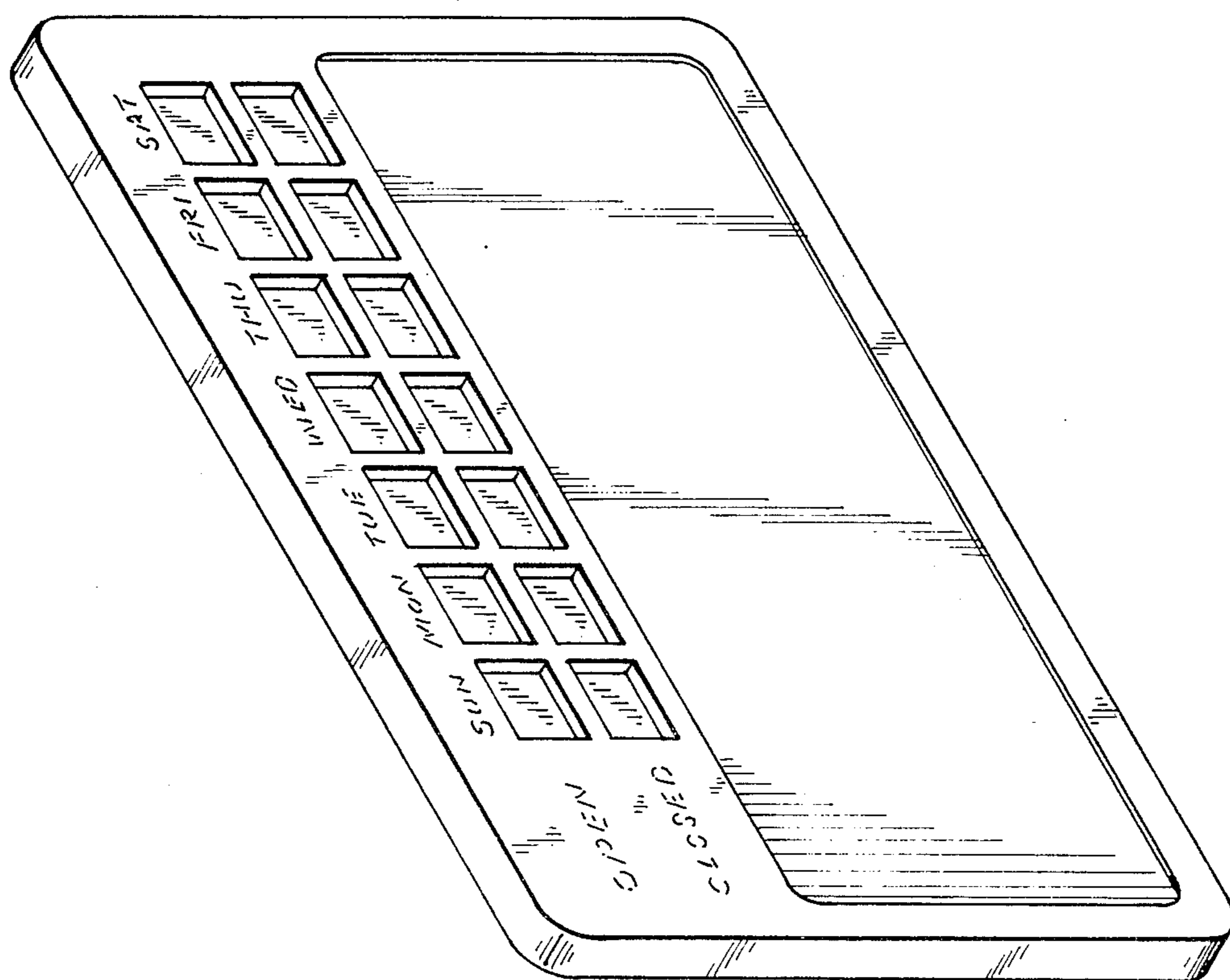

FIG. 1

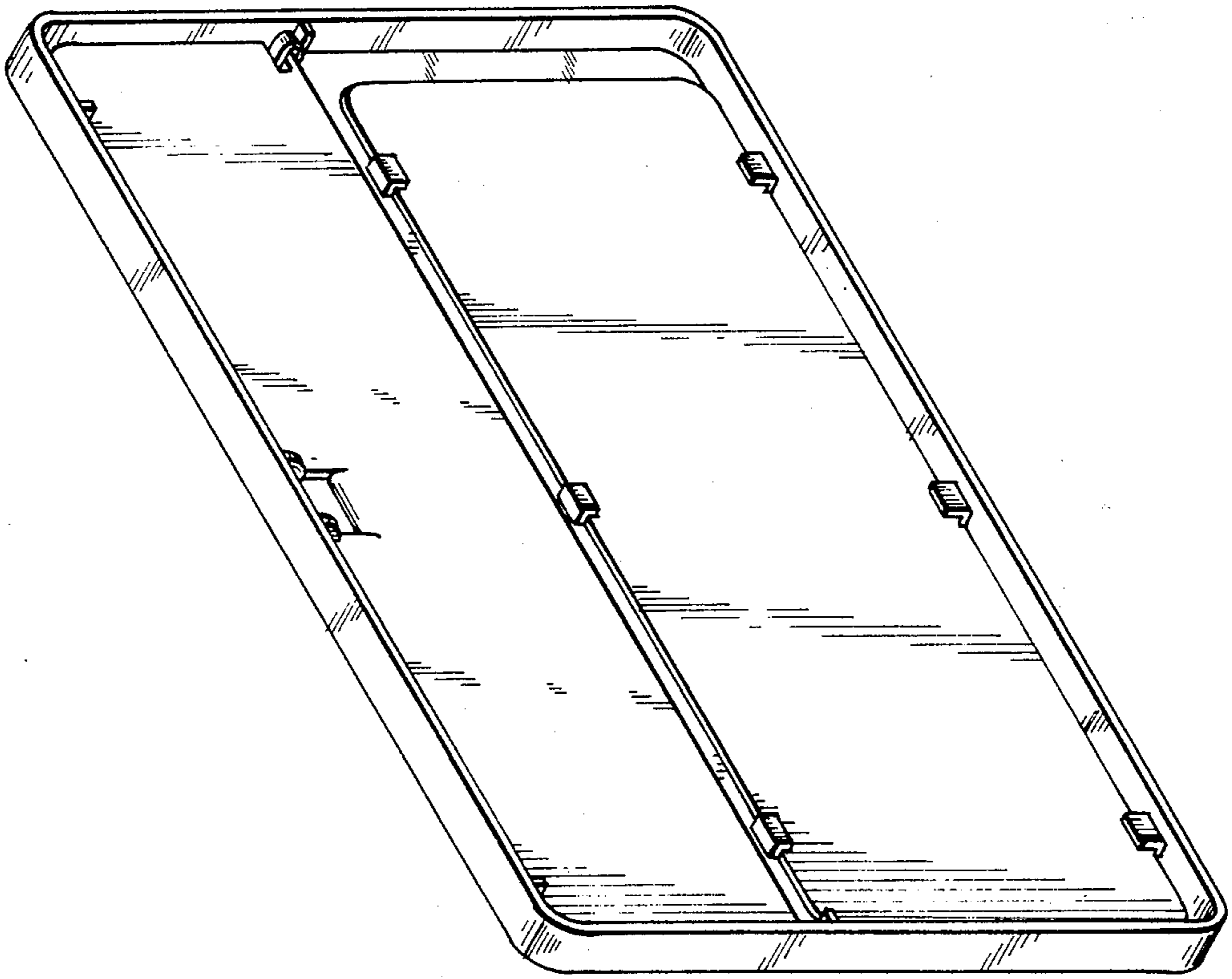

FIG. 2

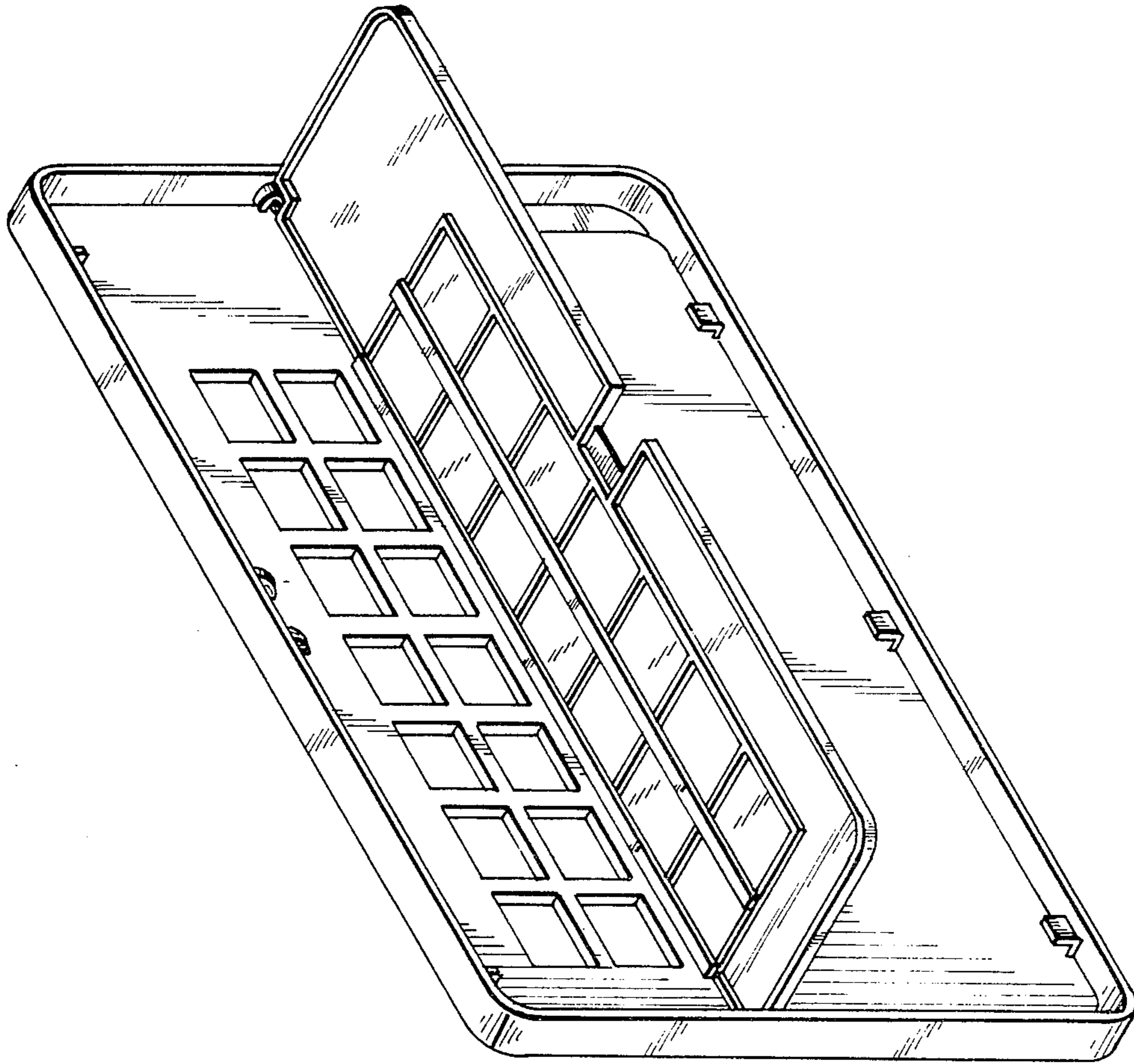

FIG. 3