

[54] **BOAT**

[75] **Inventors: Allan B. Hegg; Lloyd S. Makowski,**  
both of Manistee; **James S. Phares,**  
Farmington Hills, all of Mich.

[73] **Assignee: Century Boat Company, Manistee,**  
Mich.

[\*\*] **Term: 14 Years**

[21] **Appl. No.: 536,718**

[22] **Filed: Sep. 28, 1983**

[52] **U.S. Cl. .... D12/313**

[58] **Field of Search ..... D12/300, 318; 114/56,**  
114/355, 357, 283

[56] **References Cited**

**PUBLICATIONS**

1981 Wellcraft Marine Corp. Brochure, 310 Suncruiser.  
Bayliner Marine Corp. p. 6 3250 Conquest Sunbridge/-  
off shore express.

1981 Chris-Craft Corp. Brochure, The 1981 Sportboats,  
P. 332.

*Primary Examiner*—James M. Gandy  
*Attorney, Agent, or Firm*—Price, Heneveld, Huizenga &  
Cooper

[57] **CLAIM**

The ornamental design for a boat, as shown and de-  
scribed.

**DESCRIPTION**

FIG. 1 is a perspective view of a boat showing our new  
design;  
FIG. 2 is a top plan view thereof;  
FIG. 3 is a starboard elevational view thereof;  
FIG. 4 is a bow elevational view thereof;  
FIG. 5 is a stern elevational view thereof; and  
FIG. 6 is a bottom plan view of the starboard half of the  
boat.

The port and starboard sides of the boat bottom are  
symmetrical; and the port and starboard side elevations  
are symmetrical.

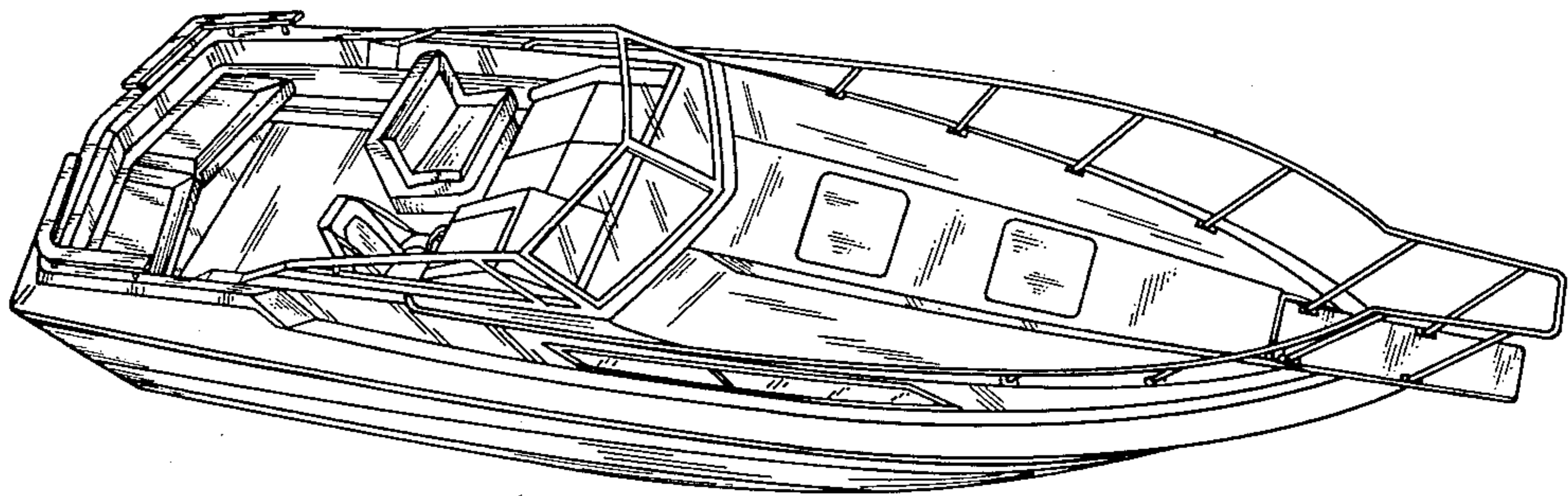

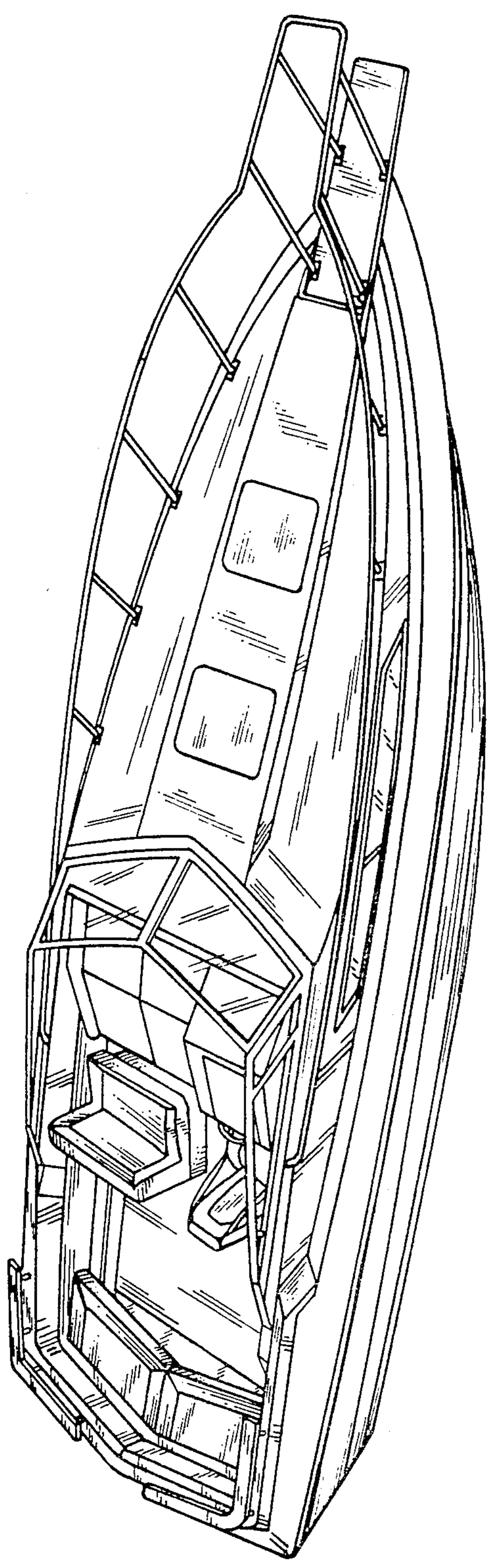

FIG. 1

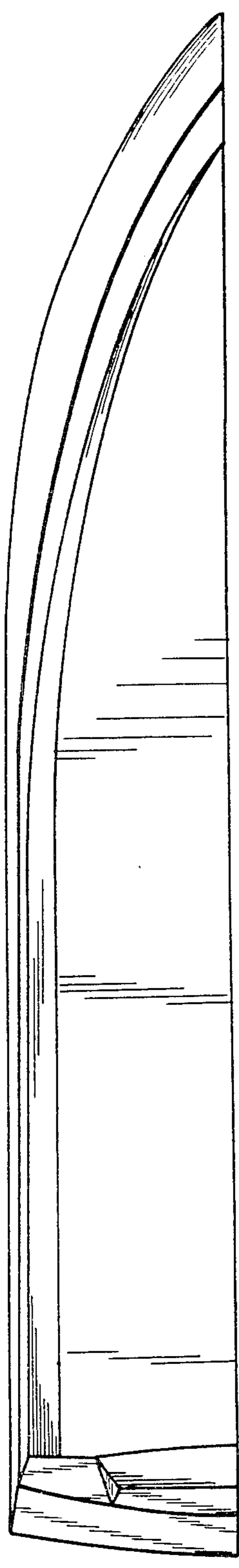

FIG. 6

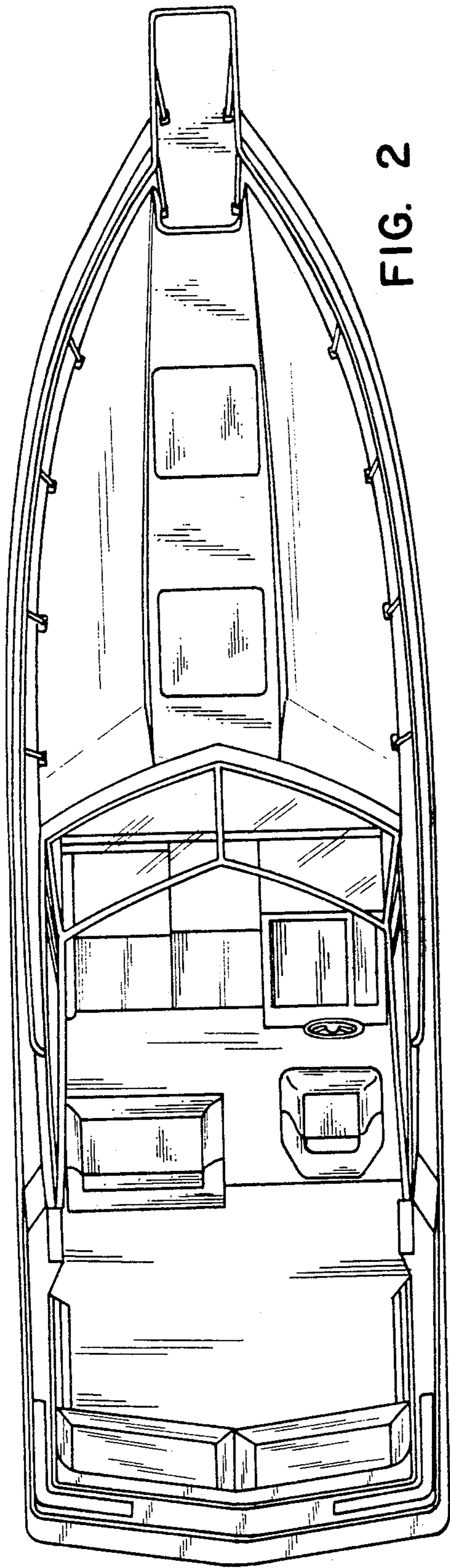

FIG. 2

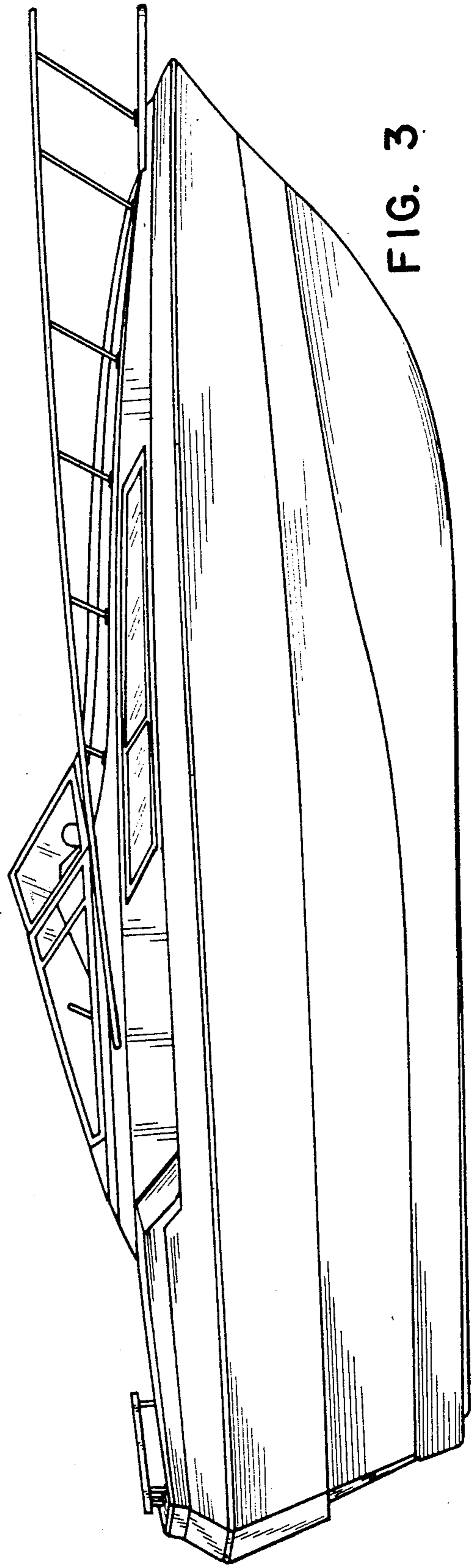

FIG. 3



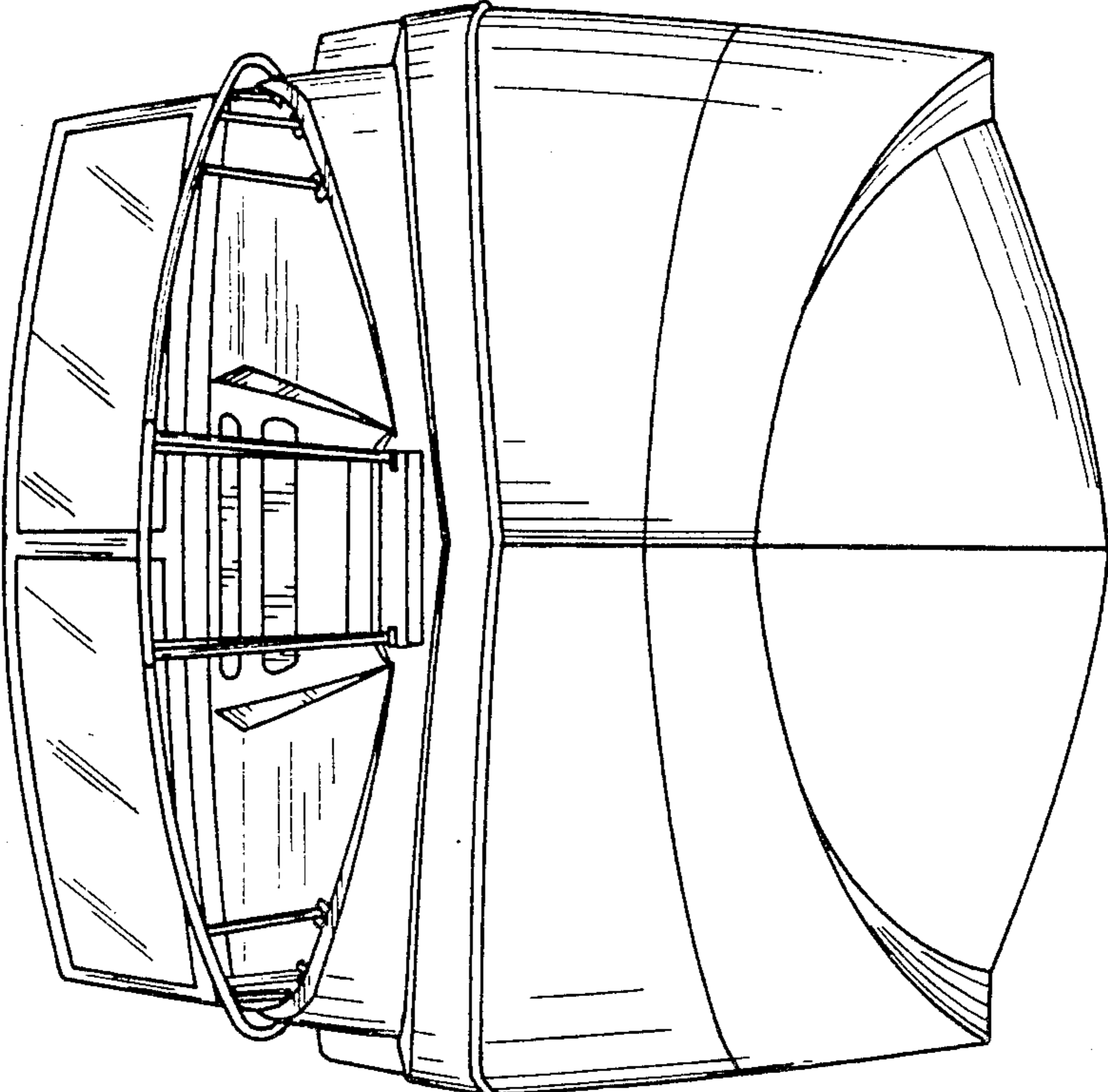

FIG. 4

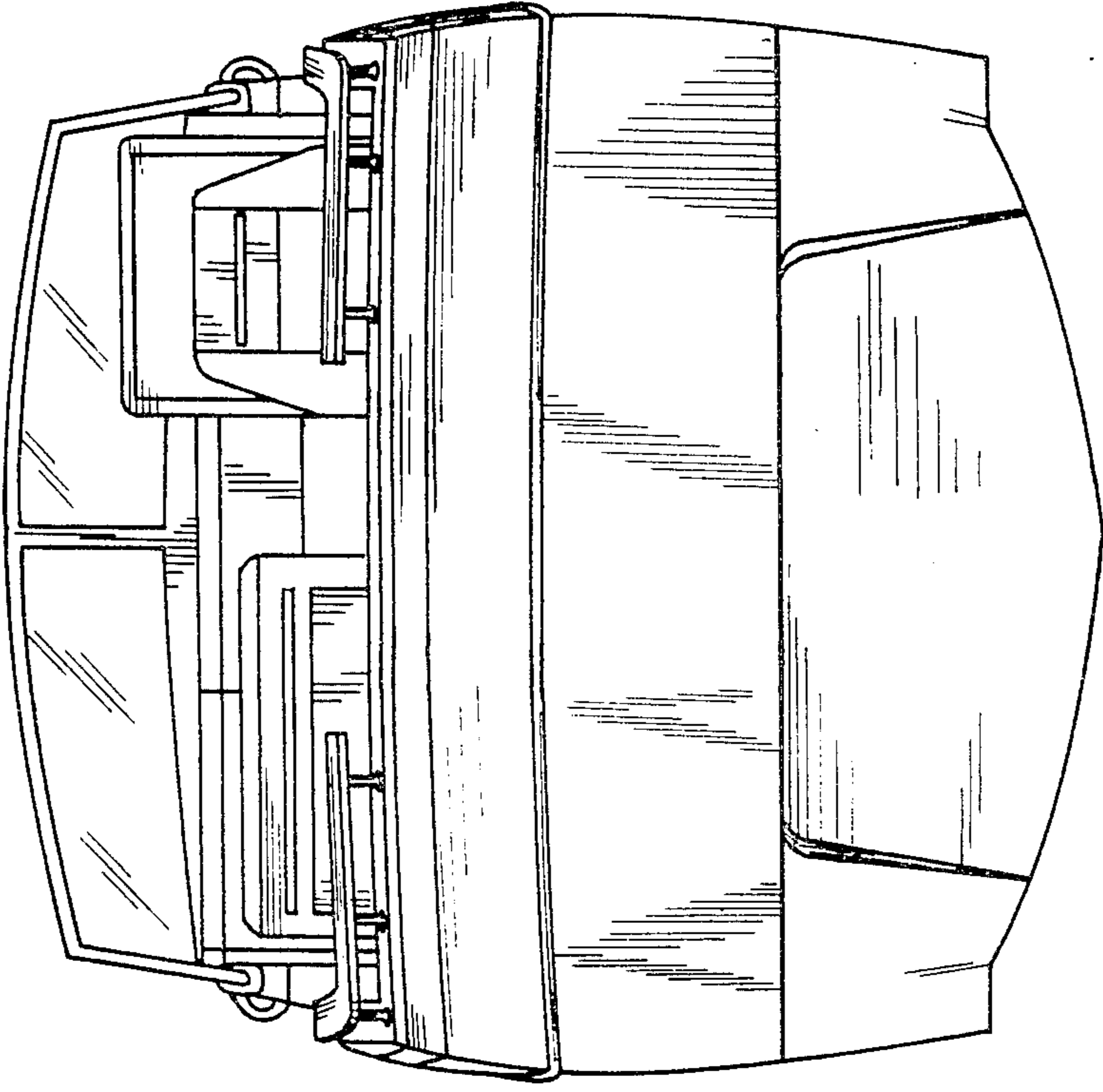

FIG. 5