

United States Patent [19]

Nelson et al.

[11] Patent Number: **Des. 284,554**

[45] Date of Patent: **** Jul. 8, 1986**

[54] **HOUSING FOR SELF-IGNITING GAS TORCH**

[75] Inventors: **John M. Nelson, Brockport; Robert M. Kahute, Honeoye Falls, both of N.Y.**

[73] Assignee: **Newell Companies, Inc., Freeport, Ill.**

[**] Term: **14 Years**

[21] Appl. No.: **478,139**

[22] Filed: **Mar. 23, 1983**

[52] U.S. Cl. **D8/30**

[58] Field of Search **D8/30; D23/90.1; 431/344, 345, 353, 354, 255, 256, 263, 265; 239/74**

[56] **References Cited**

U.S. PATENT DOCUMENTS

D. 264,301 5/1982 Miller D8/30
3,371,681 3/1968 Thomas 239/74 X

4,103,829 8/1978 Zagara et al. 431/345 X
4,348,172 9/1982 Miller 431/255
4,526,532 7/1985 Nelson 431/255

Primary Examiner—Susan J. Lucas
Attorney, Agent, or Firm—Sprung, Horn, Kramer & Woods

[57] **CLAIM**

The ornamental design for the housing for self-igniting gas torch, as shown and described.

DESCRIPTION

FIG. 1 is a top view of a housing for self-igniting gas torch;

FIG. 2 is a left side view thereof;

FIG. 3 is a right side view thereof;

FIG. 4 is a front view thereof;

FIG. 5 is a rear view thereof; and

FIG. 6 is a bottom view thereof.

The burner tube is shown in broken lines for illustrative purposes only.

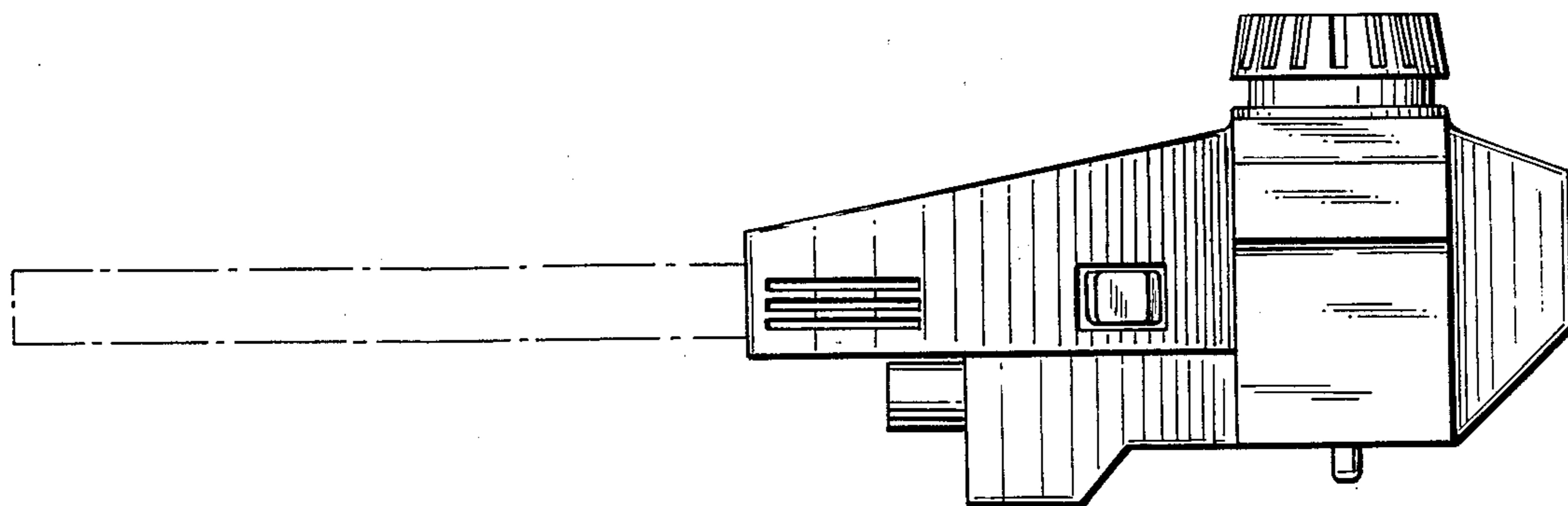

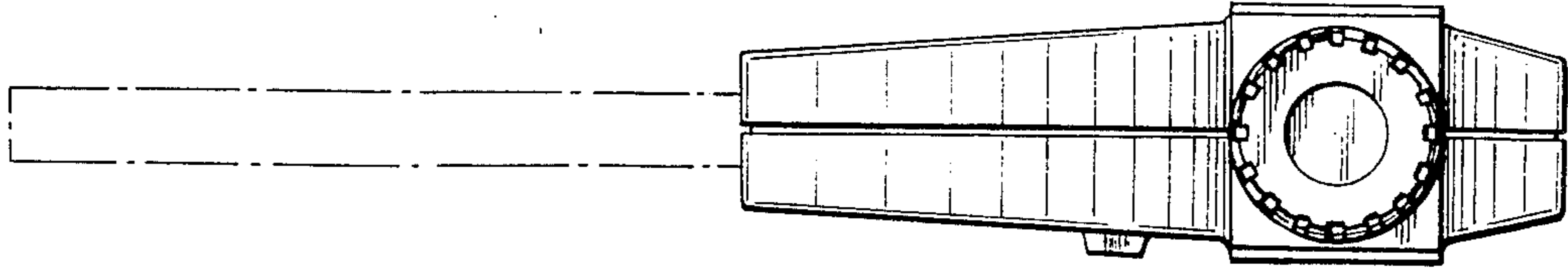

FIG. 1

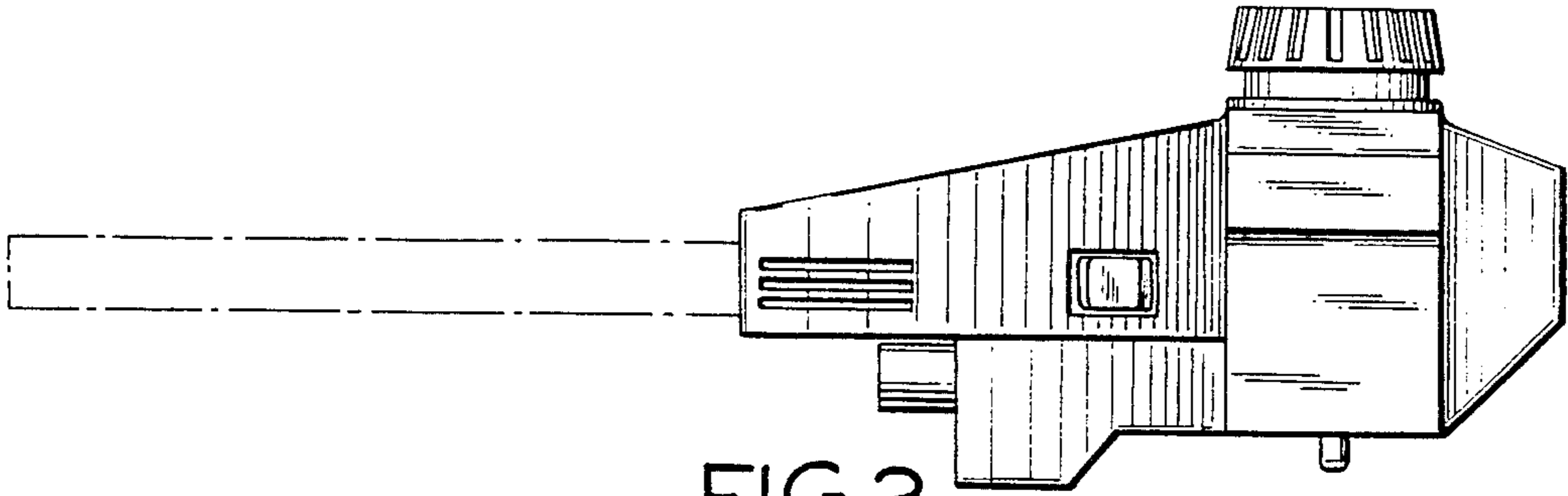

FIG. 2

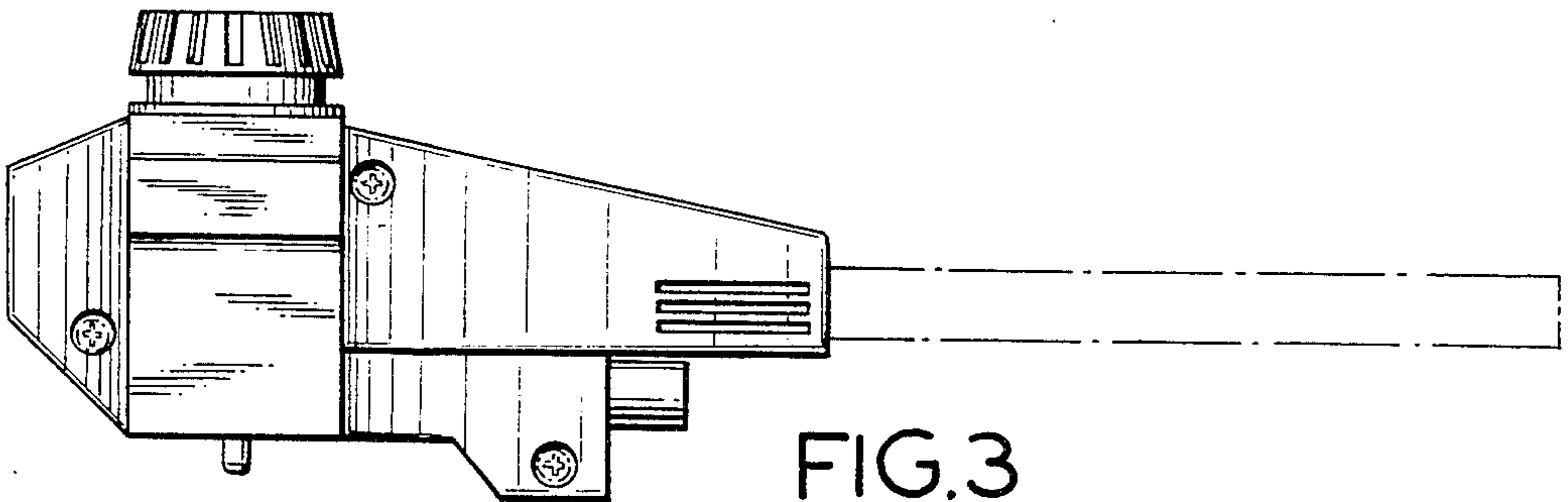

FIG. 3

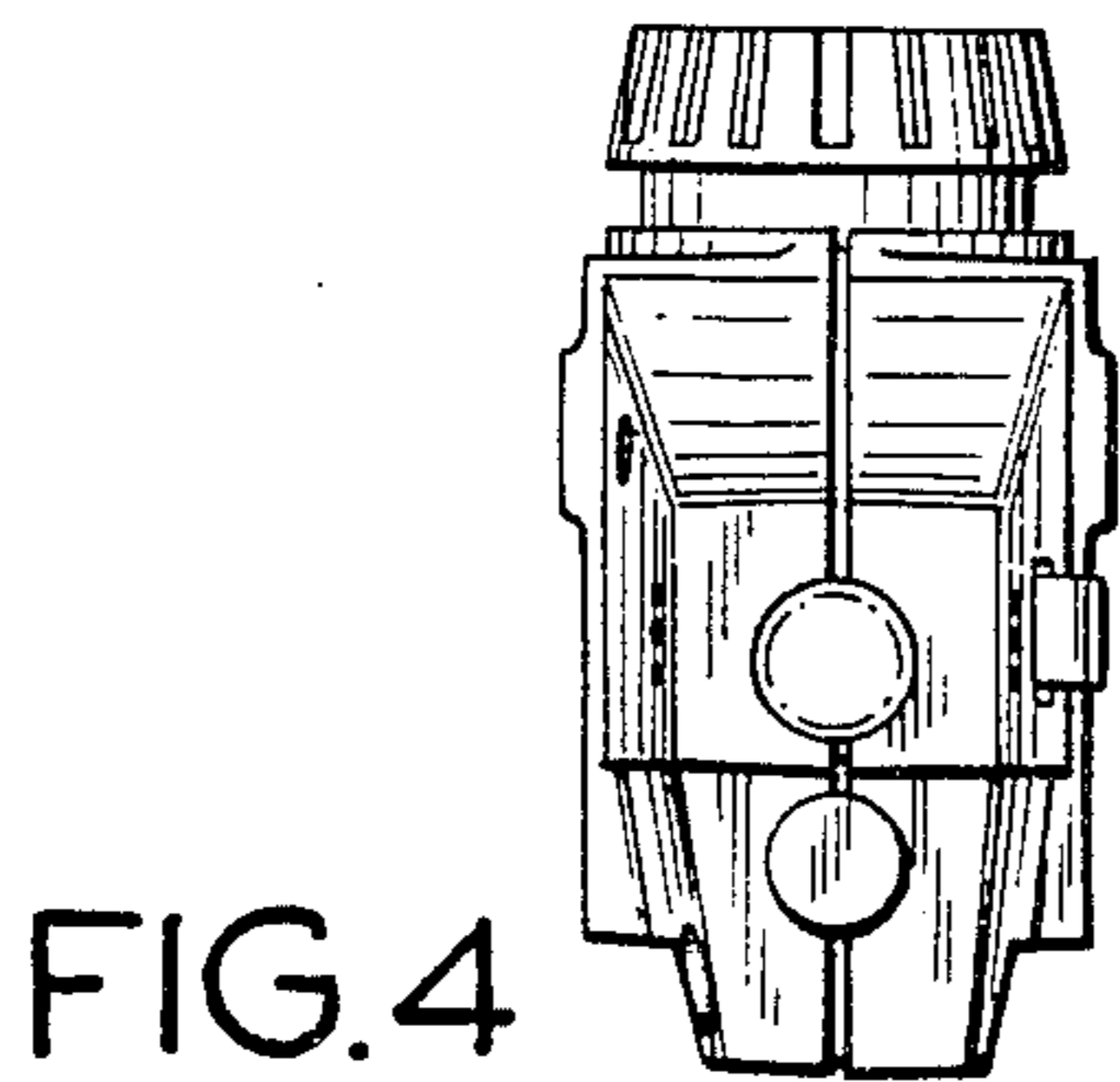

FIG. 4

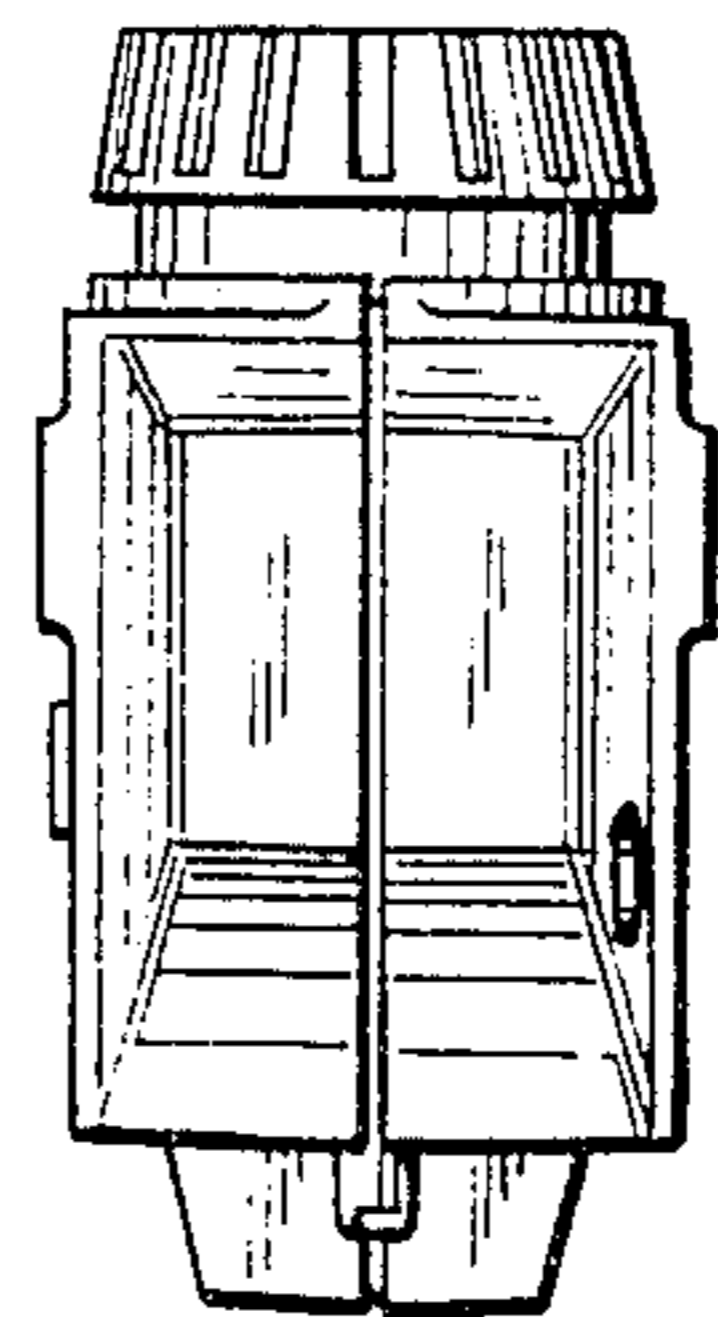

FIG. 5

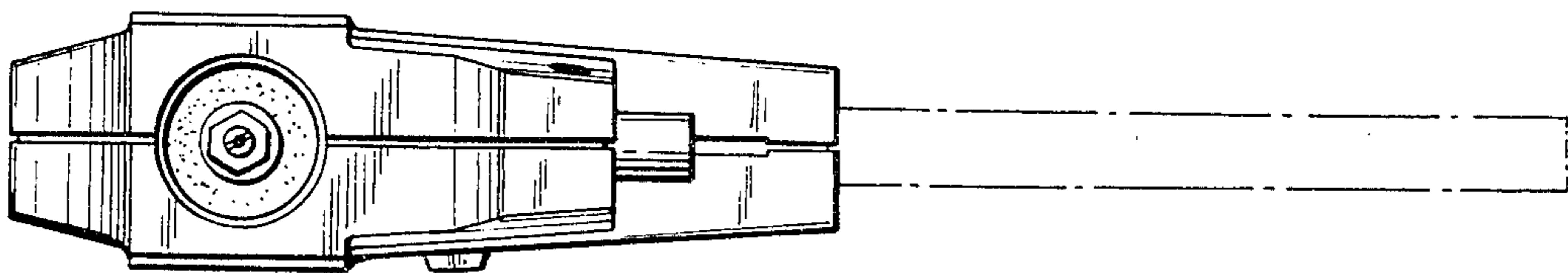

FIG. 6