

[54] STEERING COLUMN LOCK

[76] Inventor: **Hugh J. Webster**, 21482 Ellacott, Apt. 207, Warrensville Heights, Ohio 44127

[\*\*] Term: **14 Years**

[21] Appl. No.: **632,900**

[22] Filed: **Jul. 20, 1984**

[52] U.S. Cl. .... **D8/331**

[58] Field of Search ..... **D8/330-331, D8/336; 70/237, 252-253, 225, 183-184, 181, 212, 14**

[56] **References Cited**

**U.S. PATENT DOCUMENTS**

D. 274,977	8/1984	Devine .....	D8/331
1,414,991	5/1922	McKeage .....	70/252 X
1,467,530	9/1923	Clayton .....	70/253 X
1,496,813	6/1924	Liebmann .....	70/252

1,732,749	10/1929	Hershey .....	70/252
4,020,662	5/1977	Fowler .....	70/237
4,062,193	12/1977	Deleto .....	70/237 X

*Primary Examiner*—A. Hugo Word  
*Assistant Examiner*—Brian N. Vinson  
*Attorney, Agent, or Firm*—J. Helen Slough

[57] **CLAIM**

The ornamental design for a steering column lock, as shown and described.

**DESCRIPTION**

FIG. 1 is a perspective view of a steering column lock showing my new design;  
FIG. 2 is a top plan view thereof;  
FIG. 3 is a right side elevation thereof;  
FIG. 4 is a front elevation thereof;  
FIG. 5 is a rear elevation thereof;  
FIG. 6 is a left side elevation thereof; and  
FIG. 7 is a bottom plan view thereof.

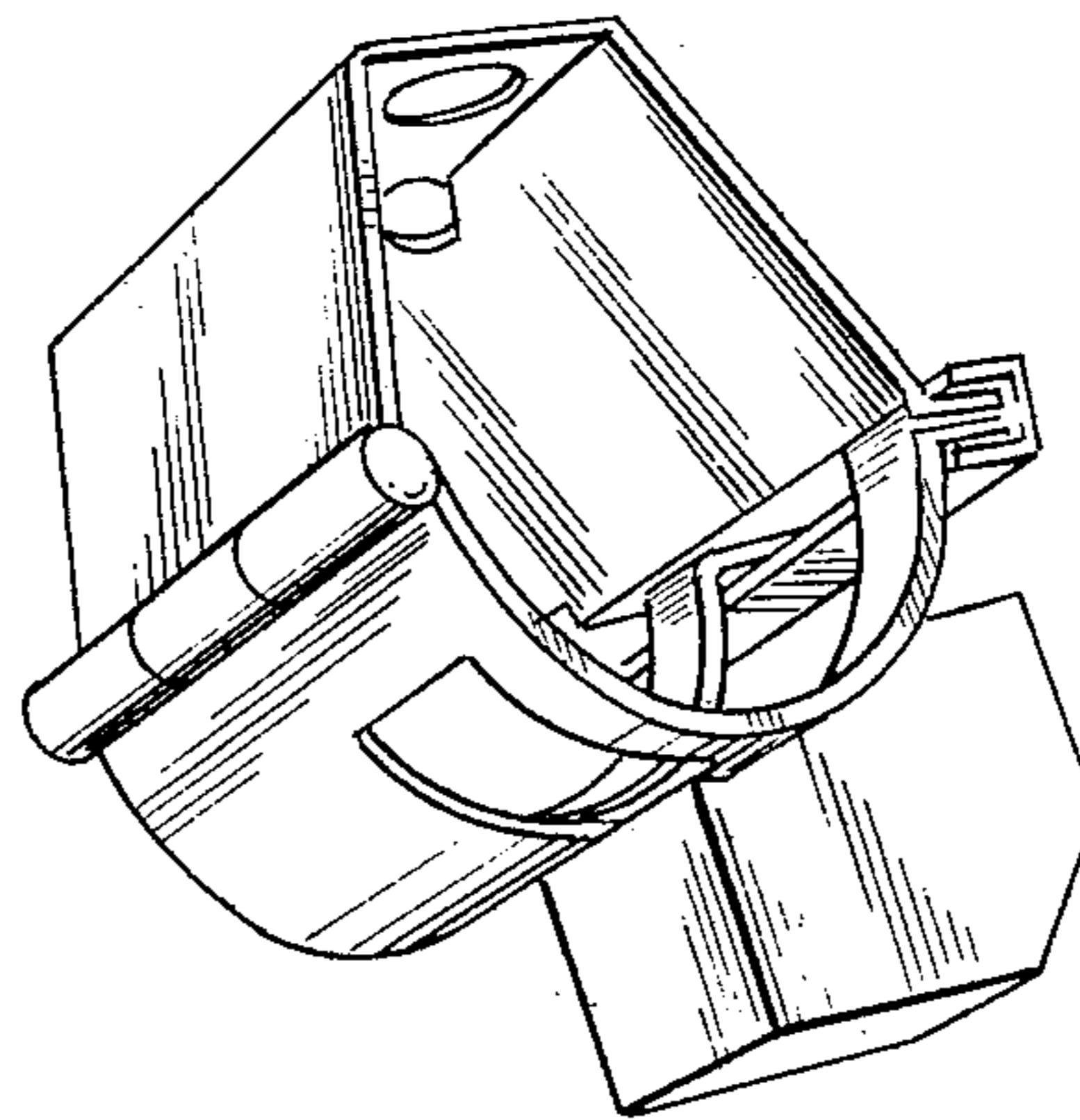

FIG. 1

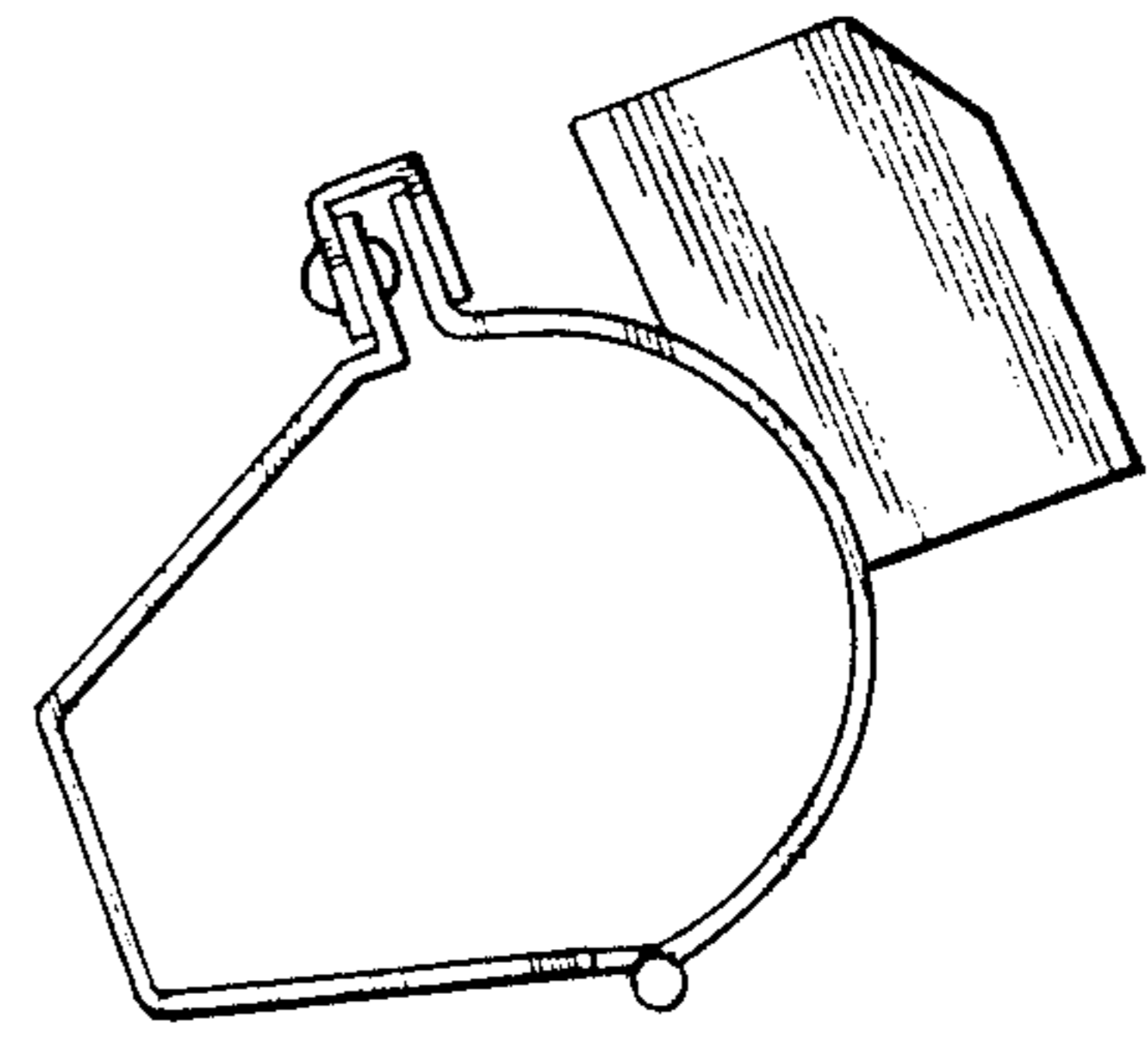
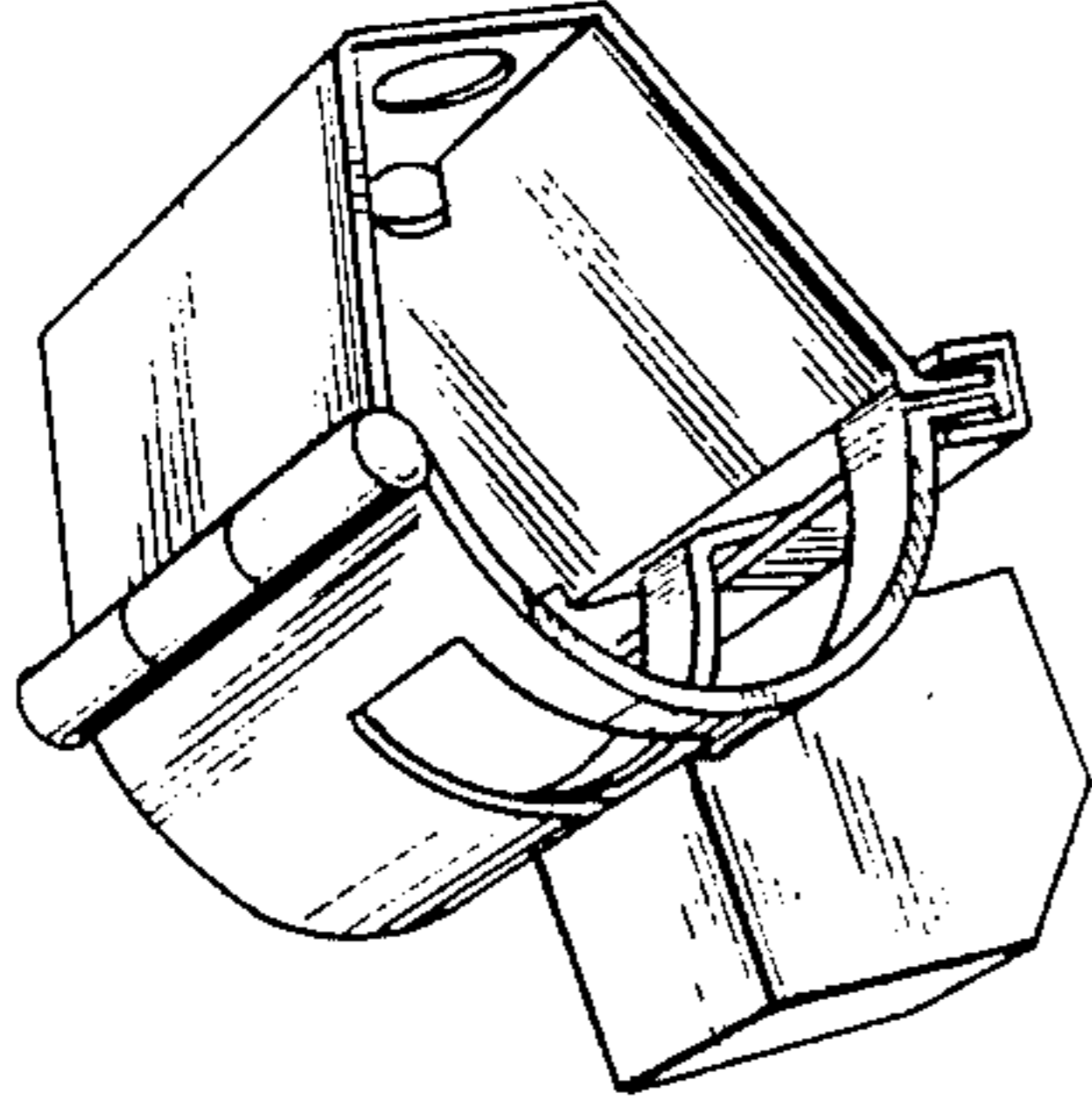

FIG. 2

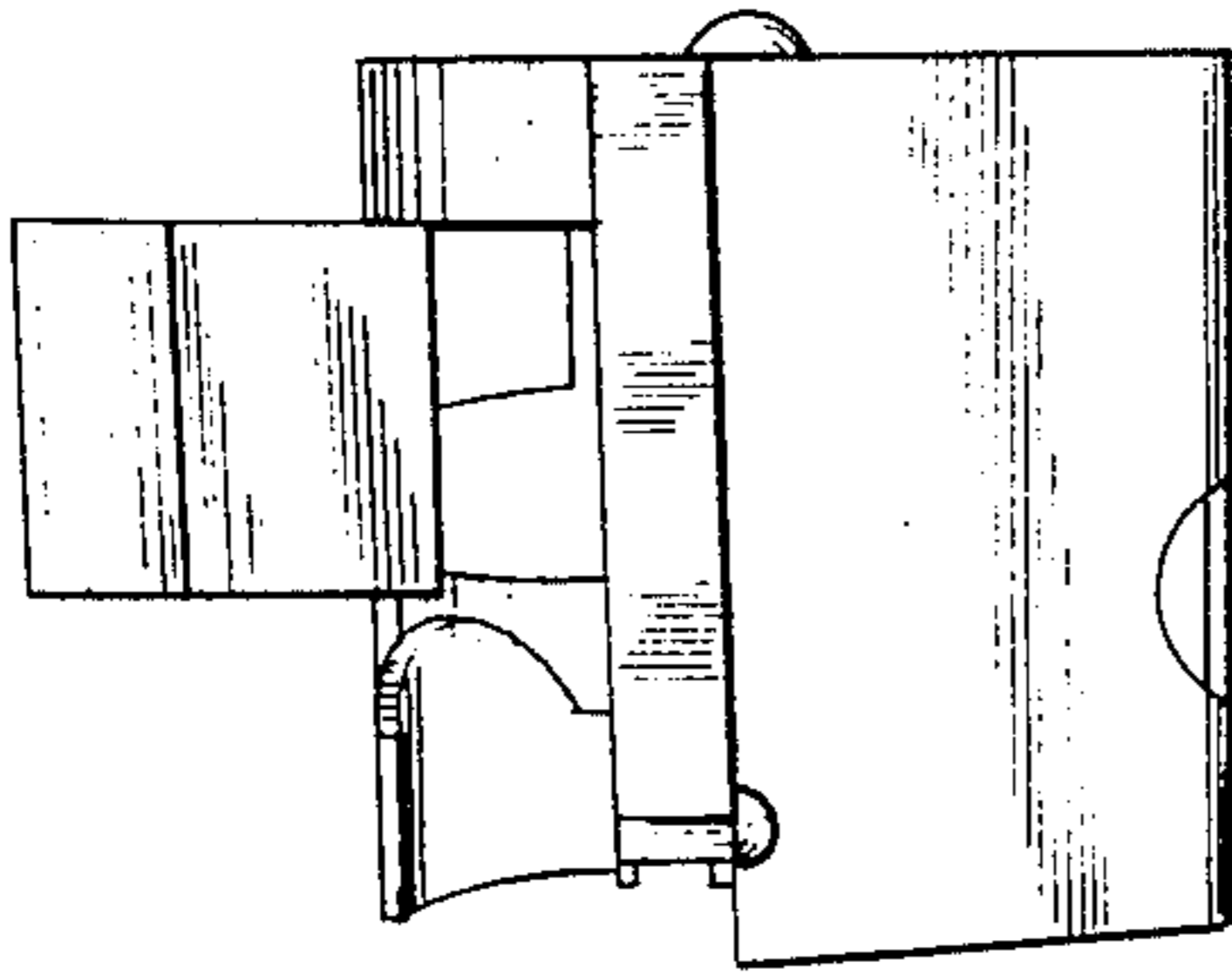

FIG. 3

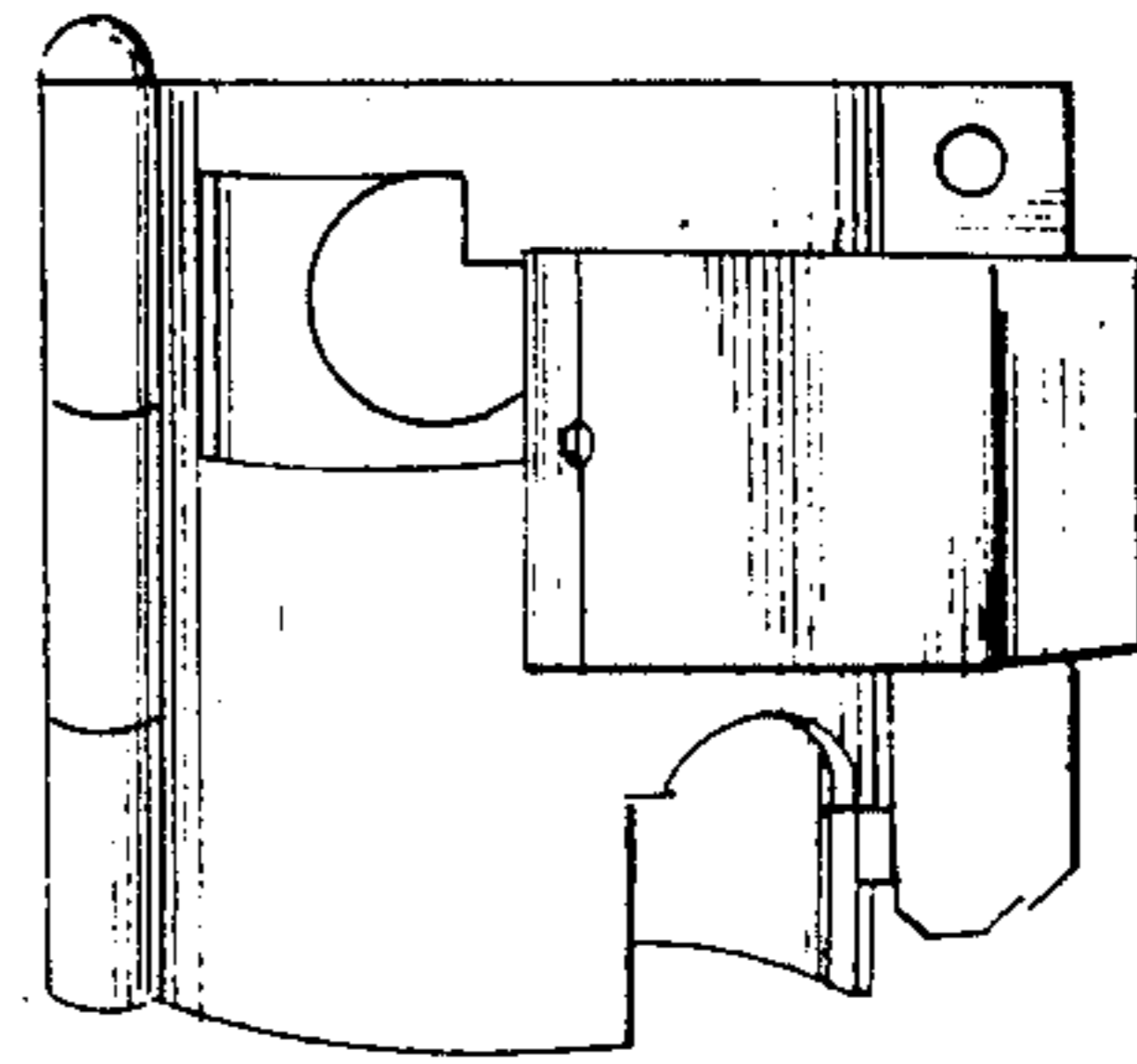

FIG. 4

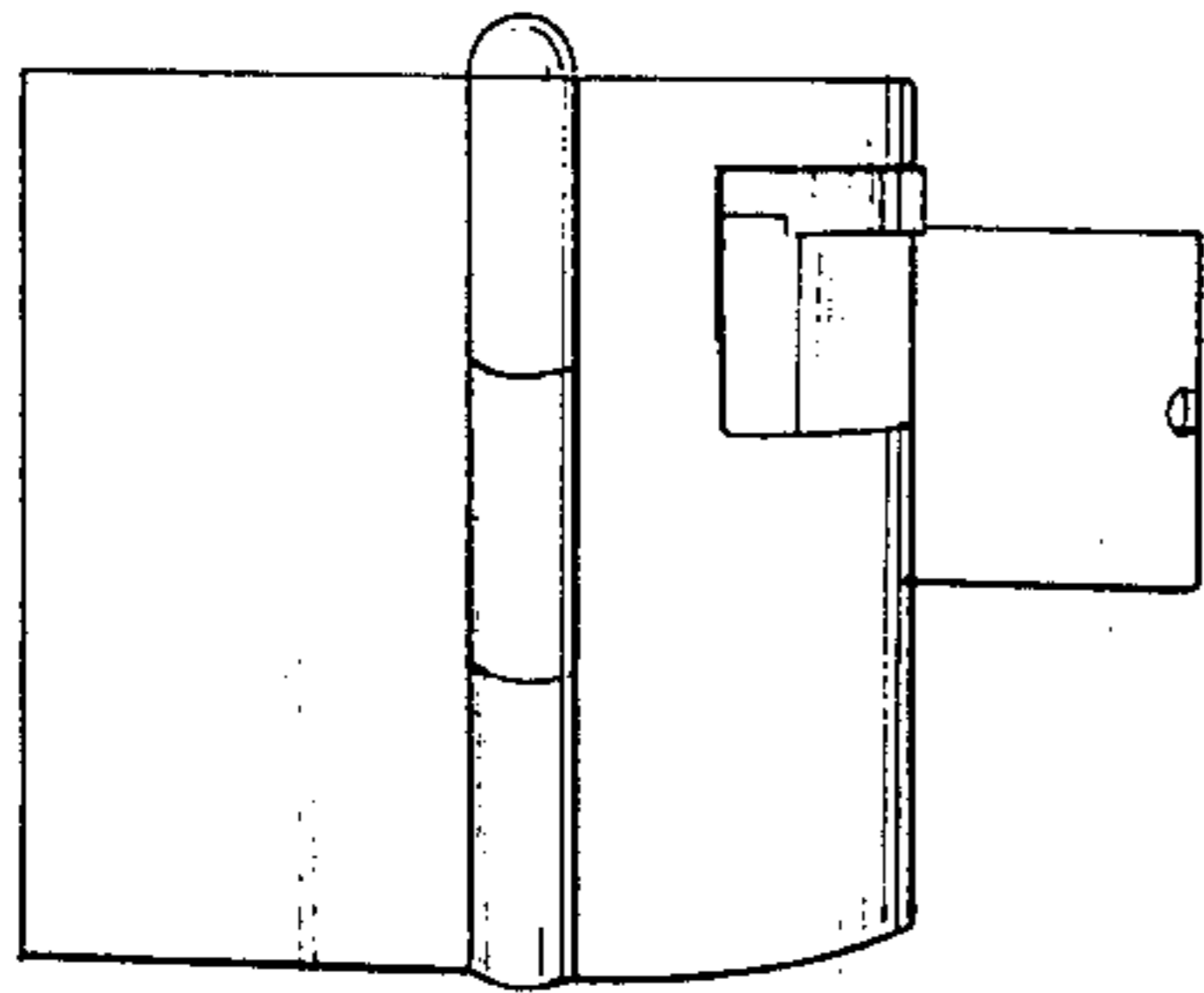

FIG. 6

FIG. 5

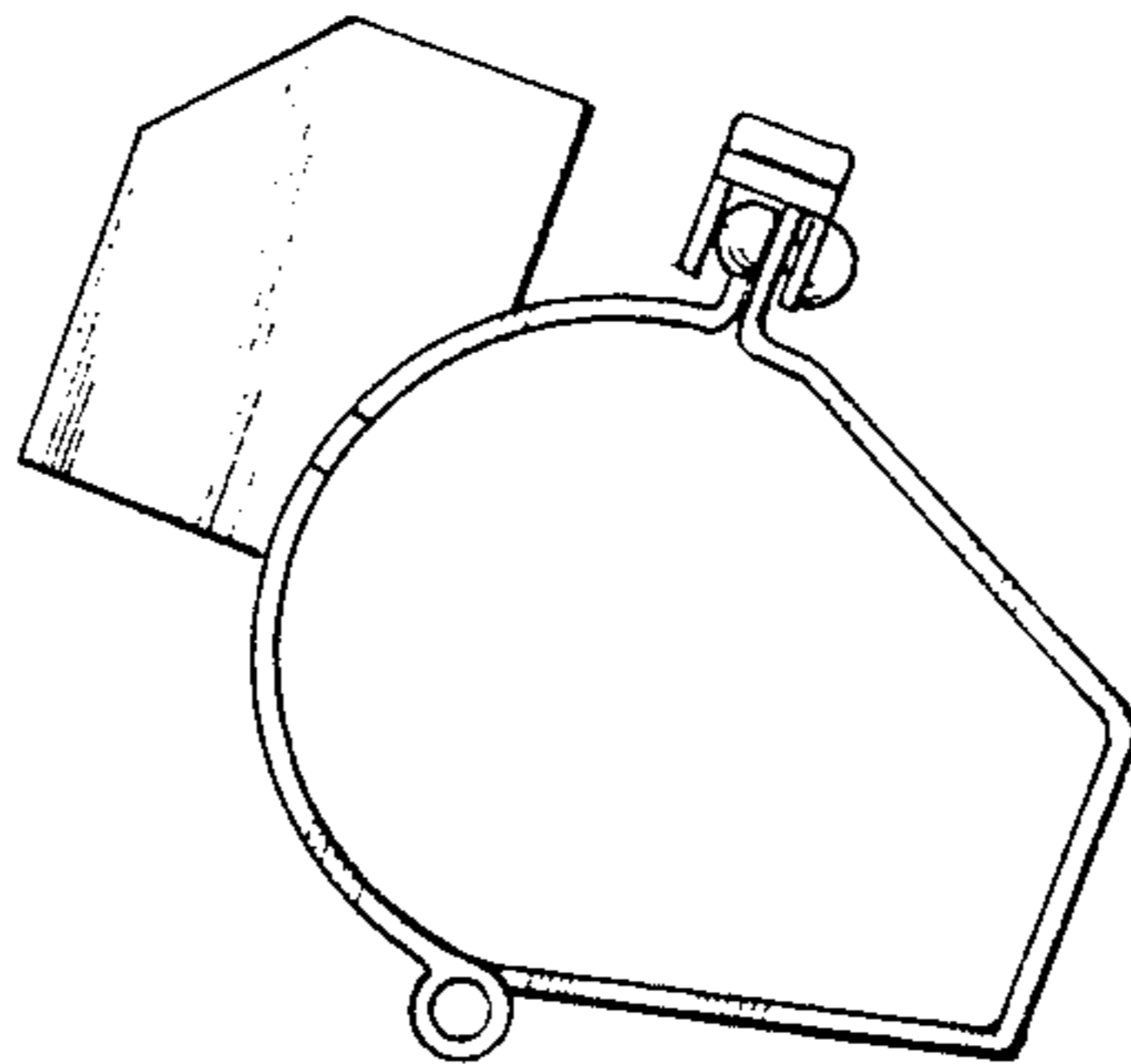
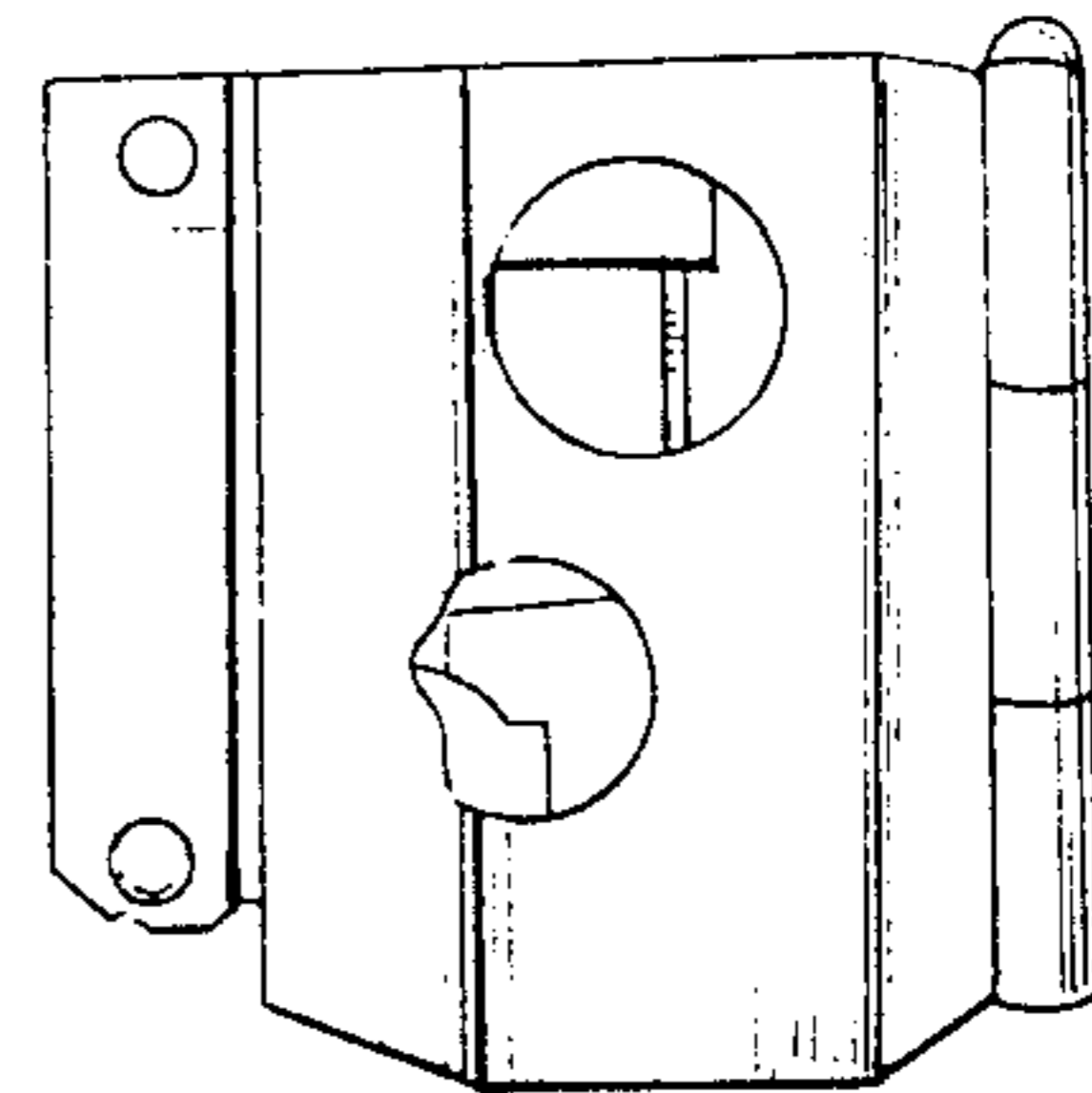

FIG. 7