

- [54] SPA
- [75] Inventor: Donald W. Doman, Janesville, Wis.
- [73] Assignee: Kohler Co., Kohler, Wis.
- [**] Term: 14 Years
- [21] Appl. No.: 488,179
- [22] Filed: Apr. 25, 1983
- [52] U.S. Cl. D24/38
- [58] Field of Search D24/37, 38, 42; D23/55,
D23/56; D25/2; 4/488, 492, 506, 513, 541, 542,
590, 592, 597, 611-614

- [56] **References Cited**
- U.S. PATENT DOCUMENTS**
- D. 240,084 5/1976 Melchior D24/38 X
- D. 265,345 7/1982 Doman D24/38

- OTHER PUBLICATIONS**
- Patio Spa Pamphlet by Encon Industries, p. 4, Brindisa 350 Spa.
- Pages 2 and 5 from a 1982 Gerico, Inc. brochure enti-

titled "Gerico Self Contained Spas Are Out Of This World!".

Primary Examiner—A. Hugo Word
Assistant Examiner—Stella M. Reid
Attorney, Agent, or Firm—Quarles & Brady

[57] **CLAIM**

The ornamental design for a spa, as shown and described.

DESCRIPTION

FIG. 1 is a top perspective view of a spa showing my new design;
 FIG. 2 is another top perspective view thereof;
 FIG. 3 is a top plan view thereof;
 FIG. 4 is a cross sectional view taken on line 4—4 in FIG. 3;
 FIG. 5 is a sectional view taken on either of lines 5—5 in FIG. 3;
 FIG. 6 is a sectional view taken on either of lines 6—6 in FIG. 3; and
 FIG. 7 is a sectional view taken on line 7—7 in FIG. 3. The fragmentary broken line representations of a bathroom island installation in FIGS. 1 and 2 are for purposes of illustration only.

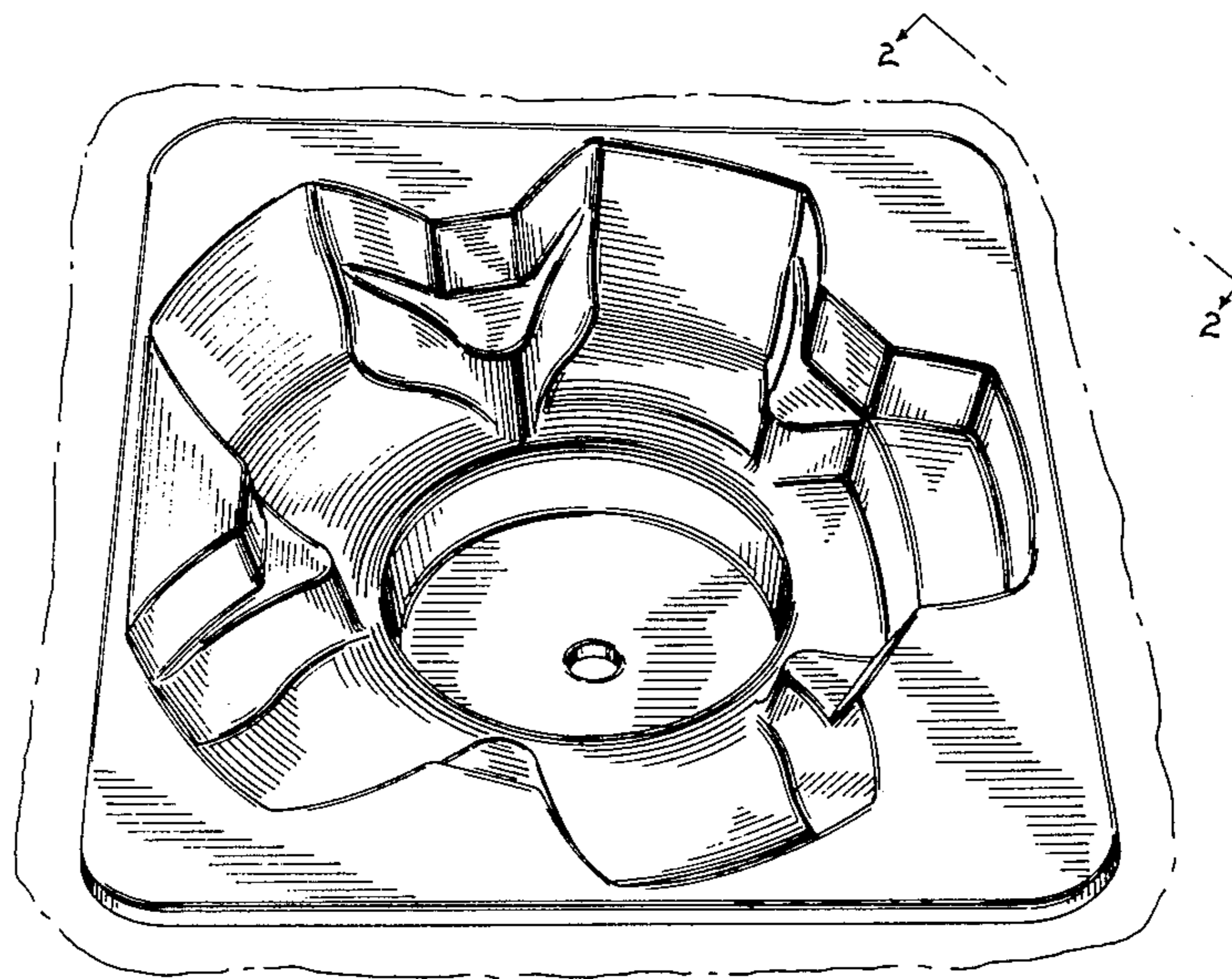

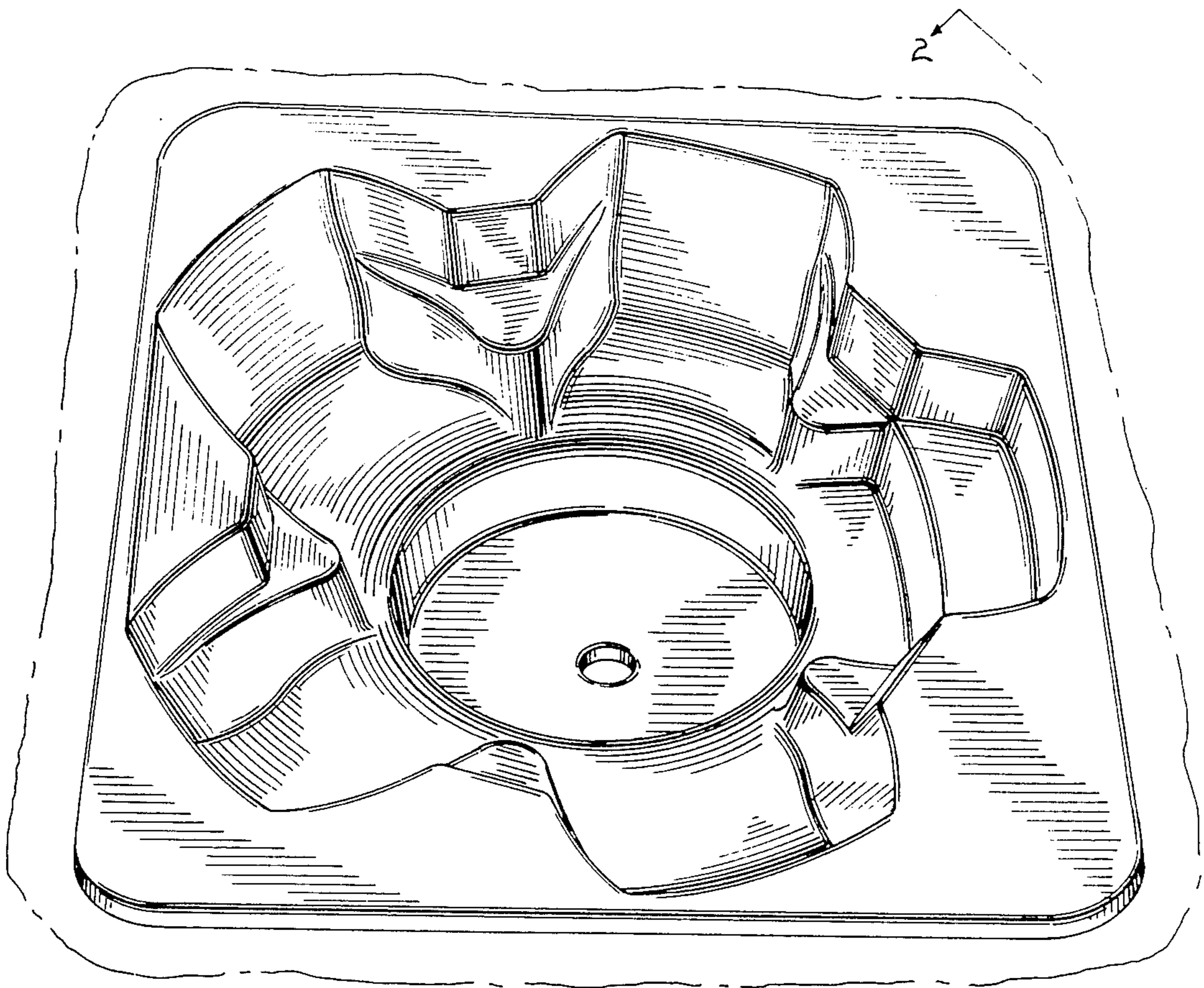

FIG. 1

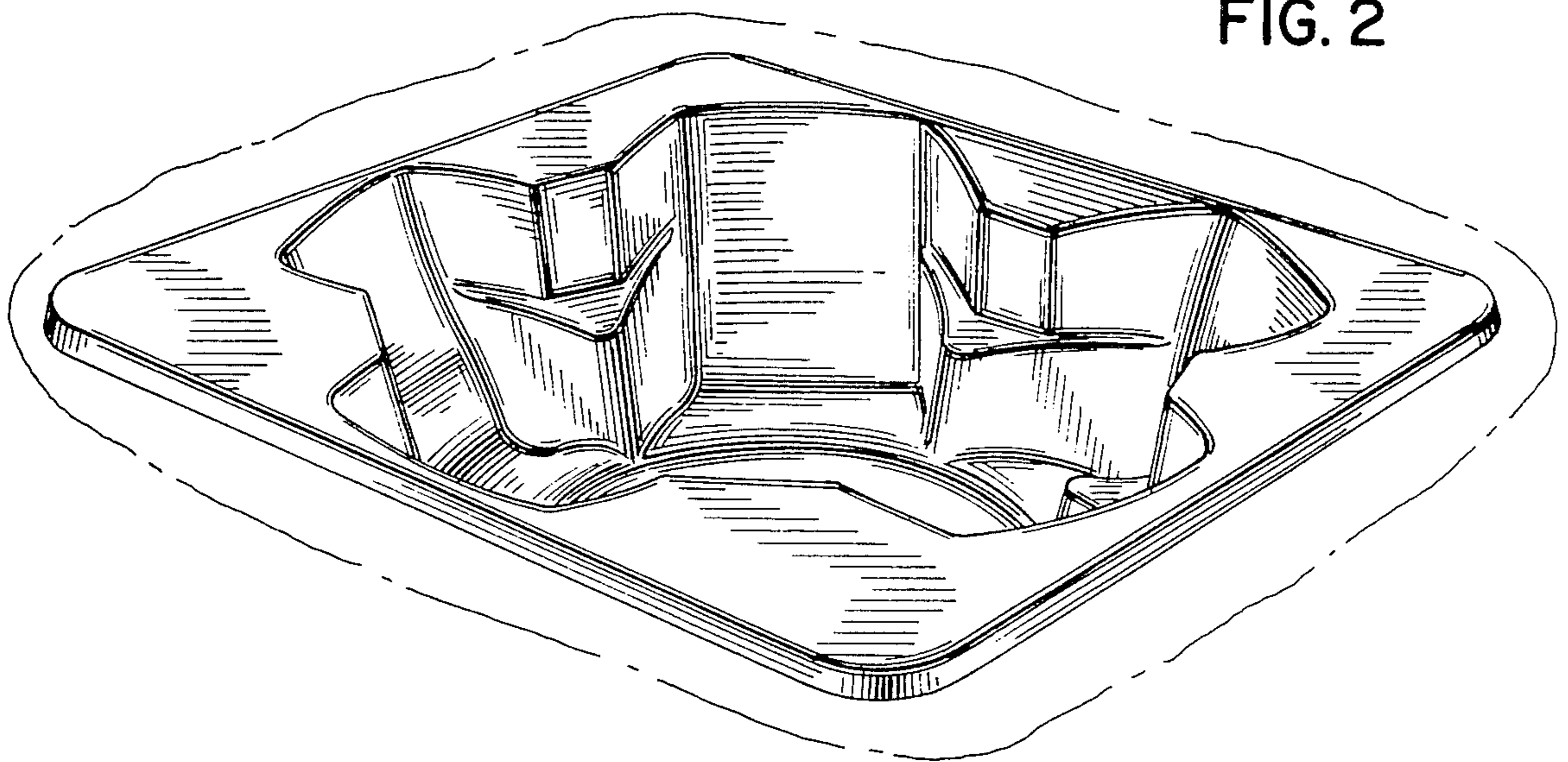

FIG. 2

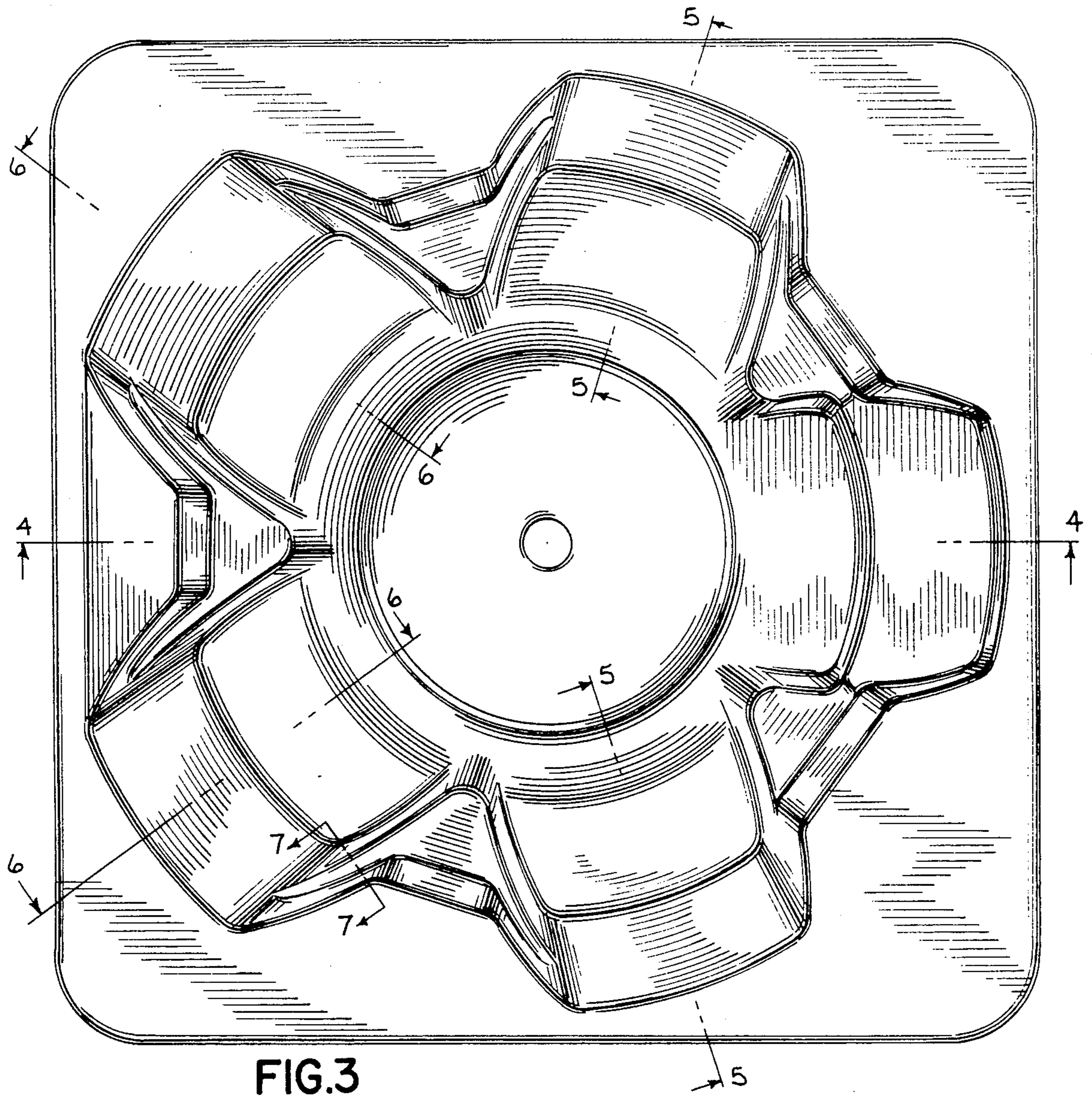

FIG.3

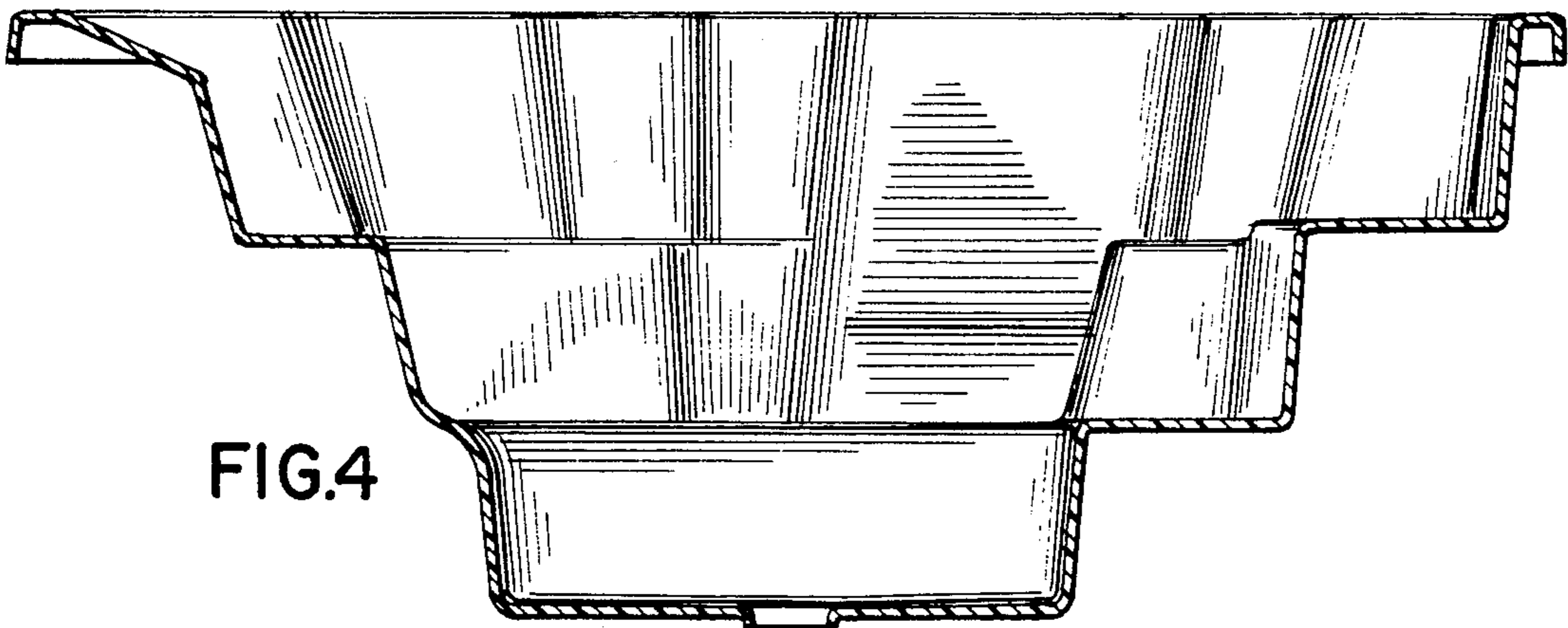

FIG.4

FIG.5

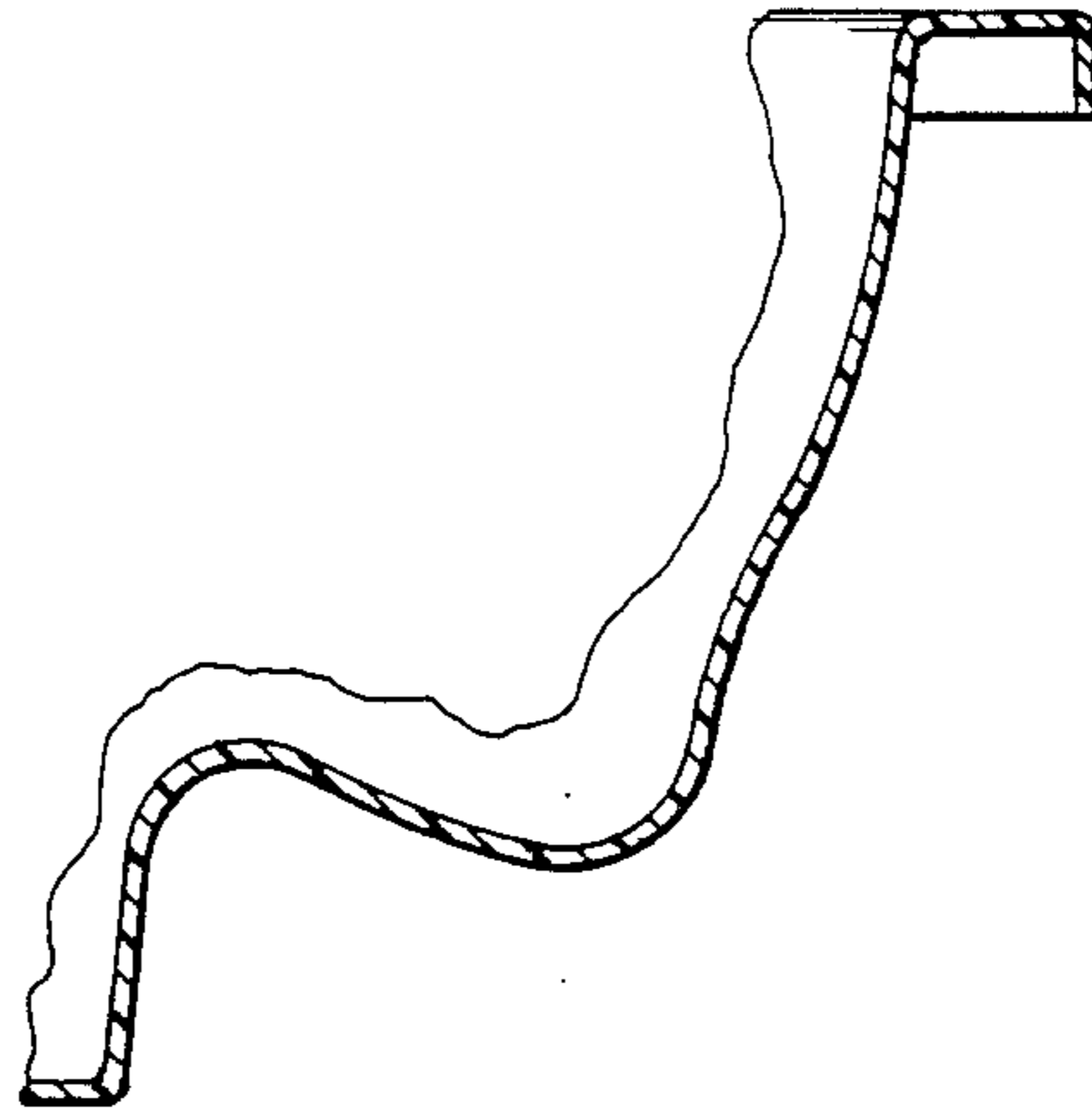

FIG.6

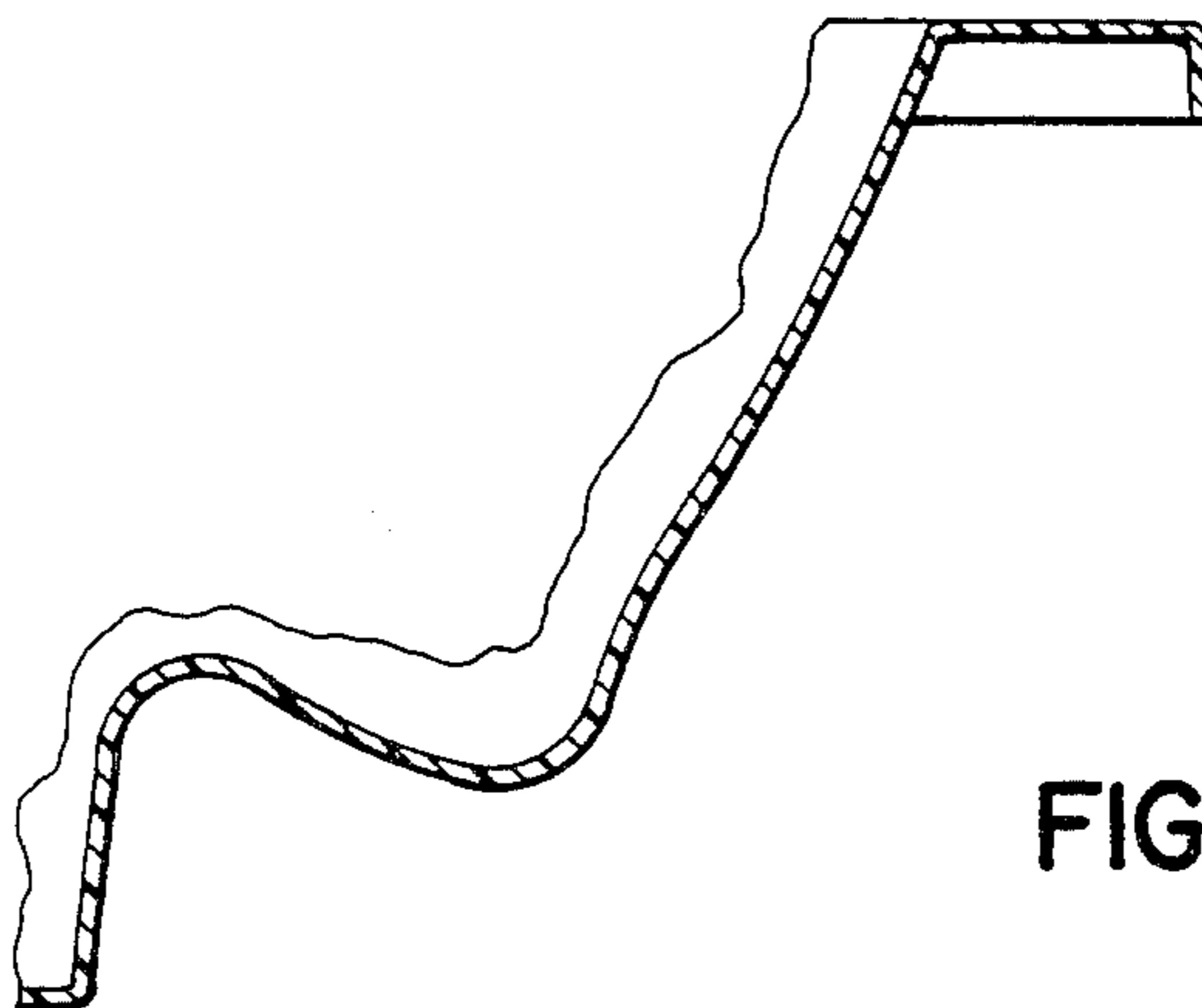

FIG.7

