

[54] LOWER FAIRING FOR MOTORCYCLES

[75] Inventor: Karl H. Abe, Steinebach/Wörthsee, Fed. Rep. of Germany

[73] Assignee: Bayerische Motoren Werke, Fed. Rep. of Germany

[\*\*] Term: 14 Years

[21] Appl. No.: 544,375

[22] Filed: Oct. 21, 1983

[30] Foreign Application Priority Data

Apr. 22, 1983 [DE] Fed. Rep. of Germany ... MR 13423

[52] U.S. Cl. .... D12/182

[58] Field of Search ..... D12/182; 296/78.1; 280/289 S

[56] References Cited

U.S. PATENT DOCUMENTS

D. 264,704 6/1982 Rehberg ..... D12/114

OTHER PUBLICATIONS

Cycle World, 4/82, p. 69, Honda Lower Fairing, bottom center of page.  
Road & Track, 10/82, p. 103, Front Grille of BMW 635csi, top left side of page.

Primary Examiner—James M. Gandy  
Attorney, Agent, or Firm—Craig and Burns

[57] CLAIM

The ornamental design for a lower fairing for motorcycles, as shown and described.

DESCRIPTION

FIG. 1 is a perspective view from one side of the front and above of the lower fairing for motorcycles embodying my novel design;  
FIG. 2 is a front elevation view thereof;  
FIG. 3 is an elevation view from one side thereof;  
FIG. 4 is an elevation view from the other side thereof;  
FIG. 5 is a rear elevation view thereof;  
FIG. 6 is a top plan view thereof; and  
FIG. 7 is a bottom plan view thereof.

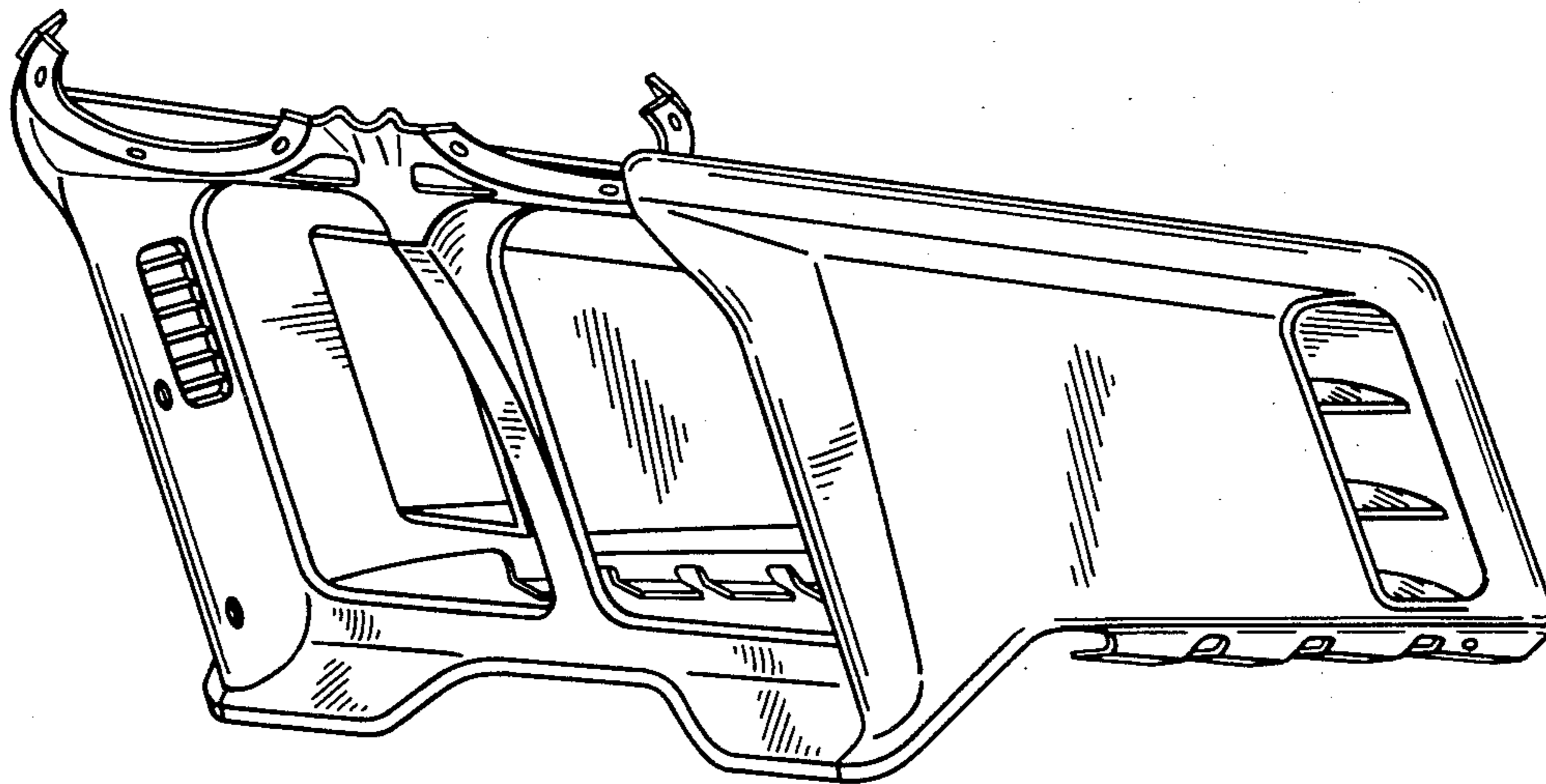

***Fig. 1***

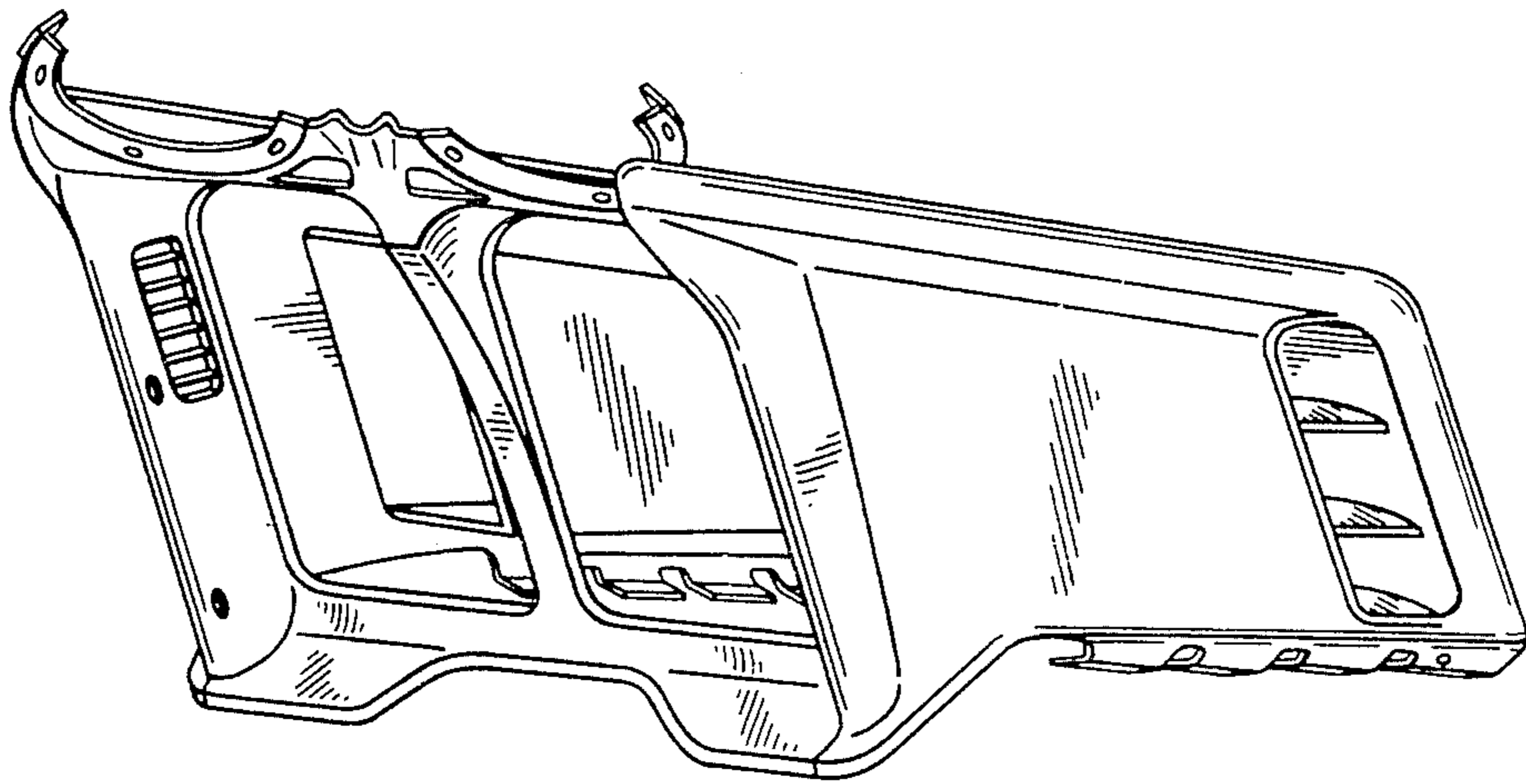

***Fig. 2***

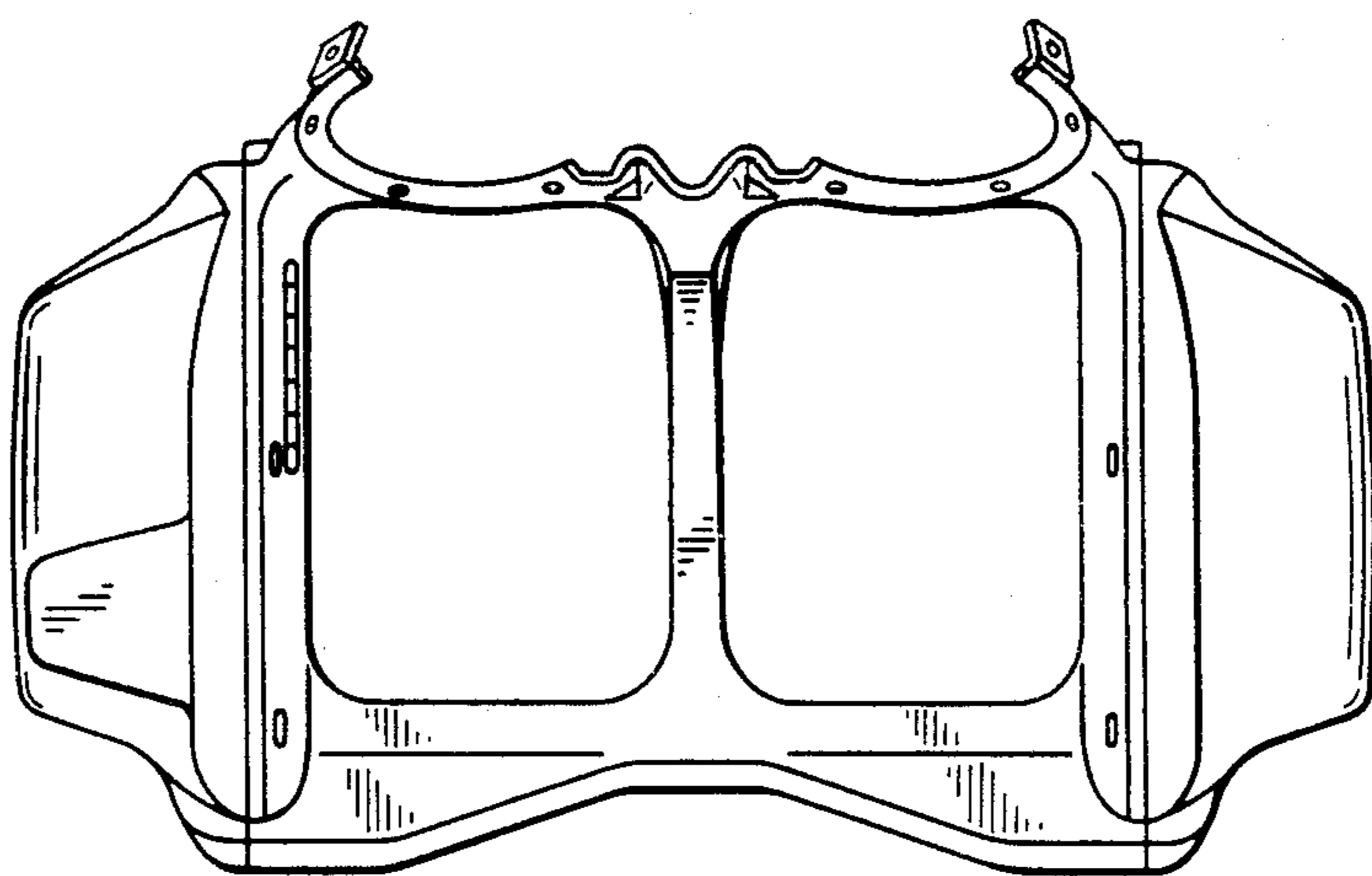

***Fig. 3***

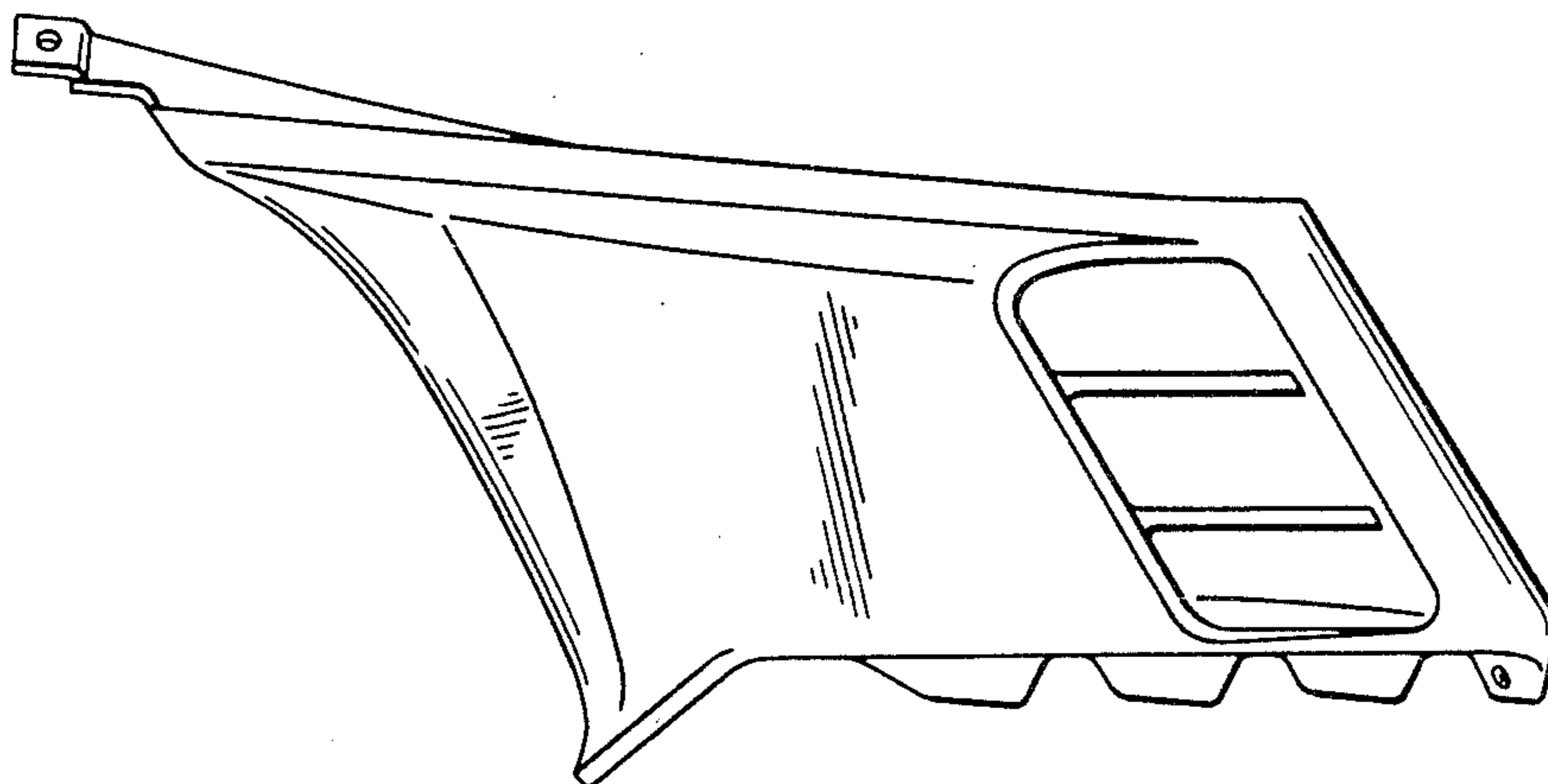

**Fig. 4**

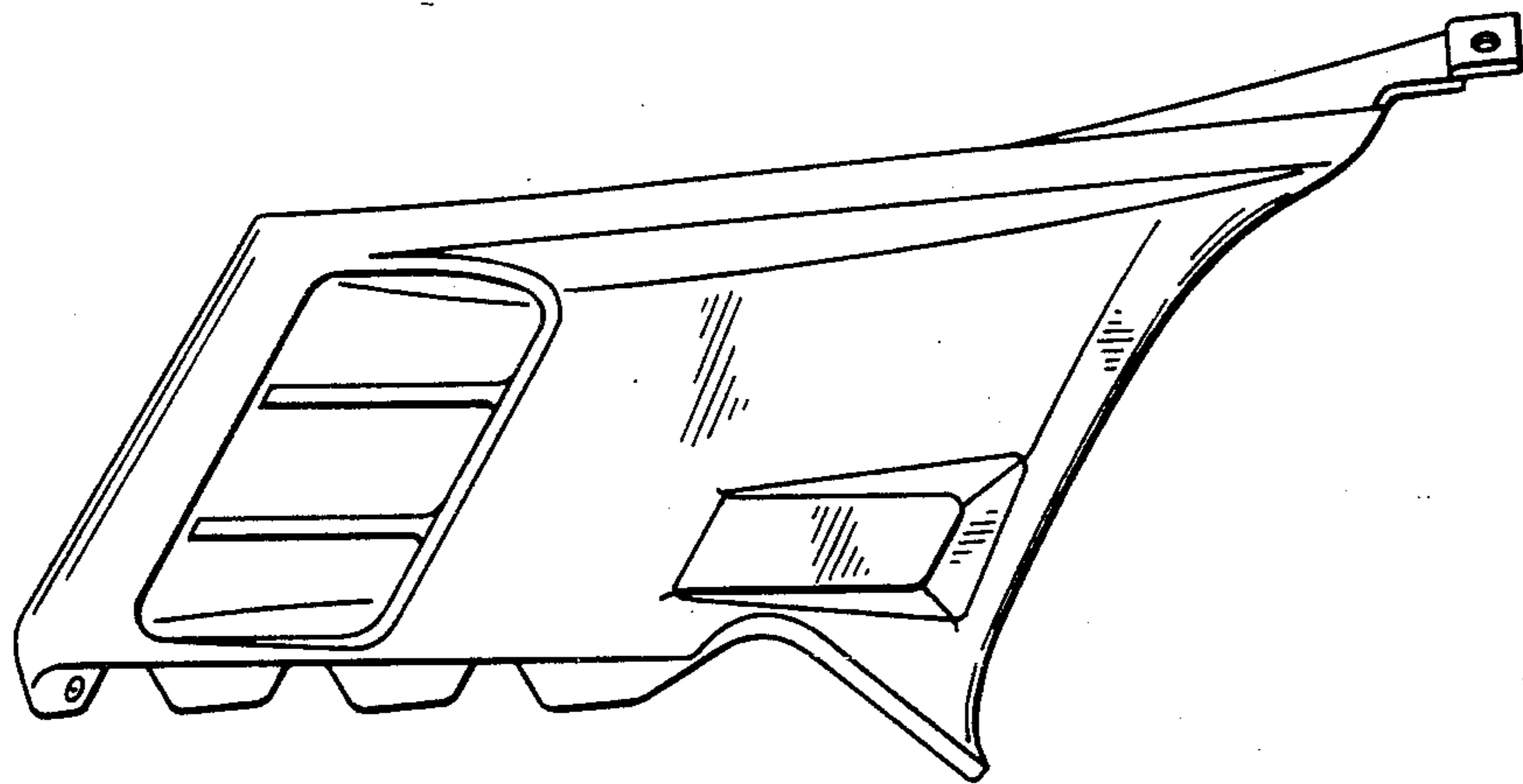

***Fig. 5***

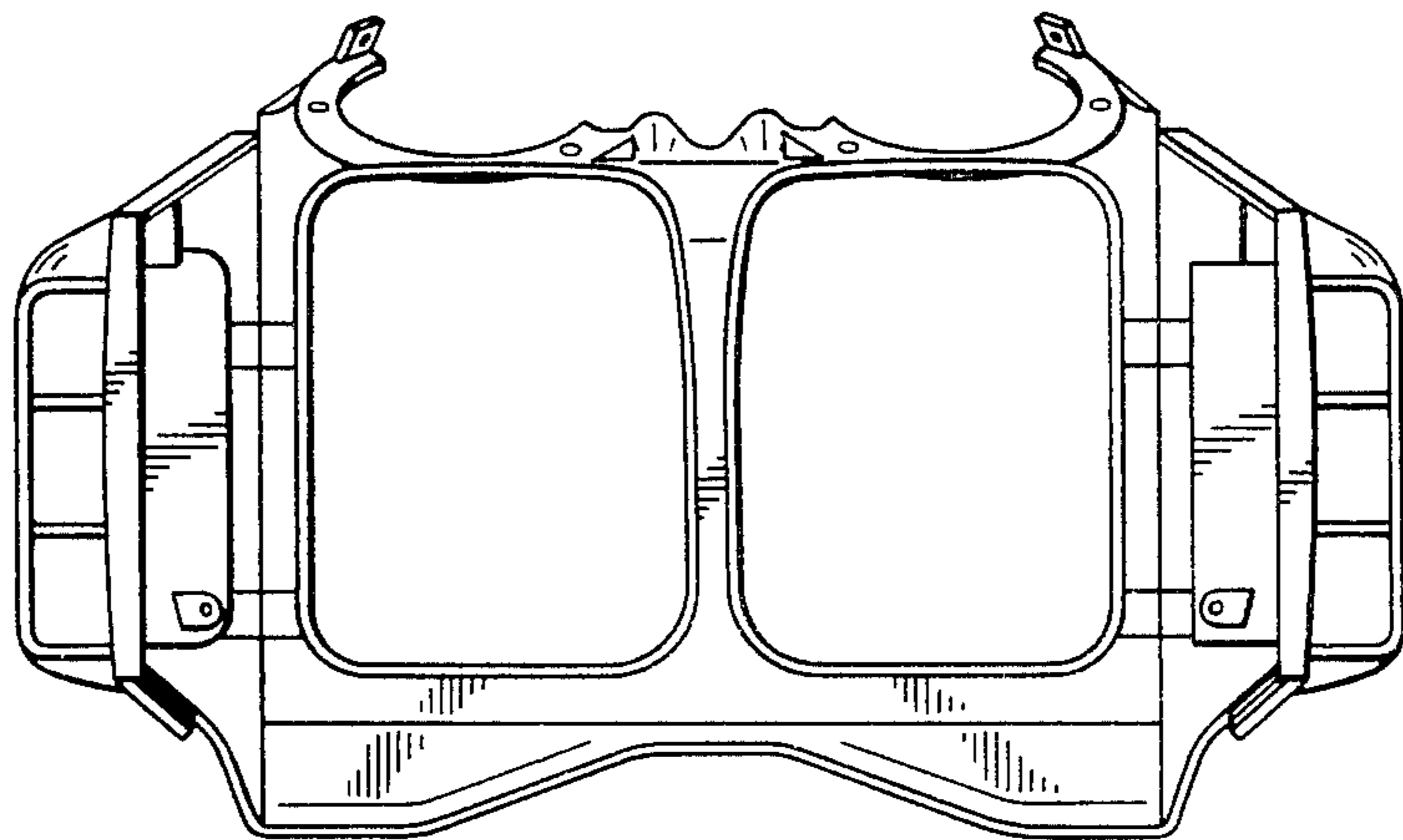

***Fig. 6***

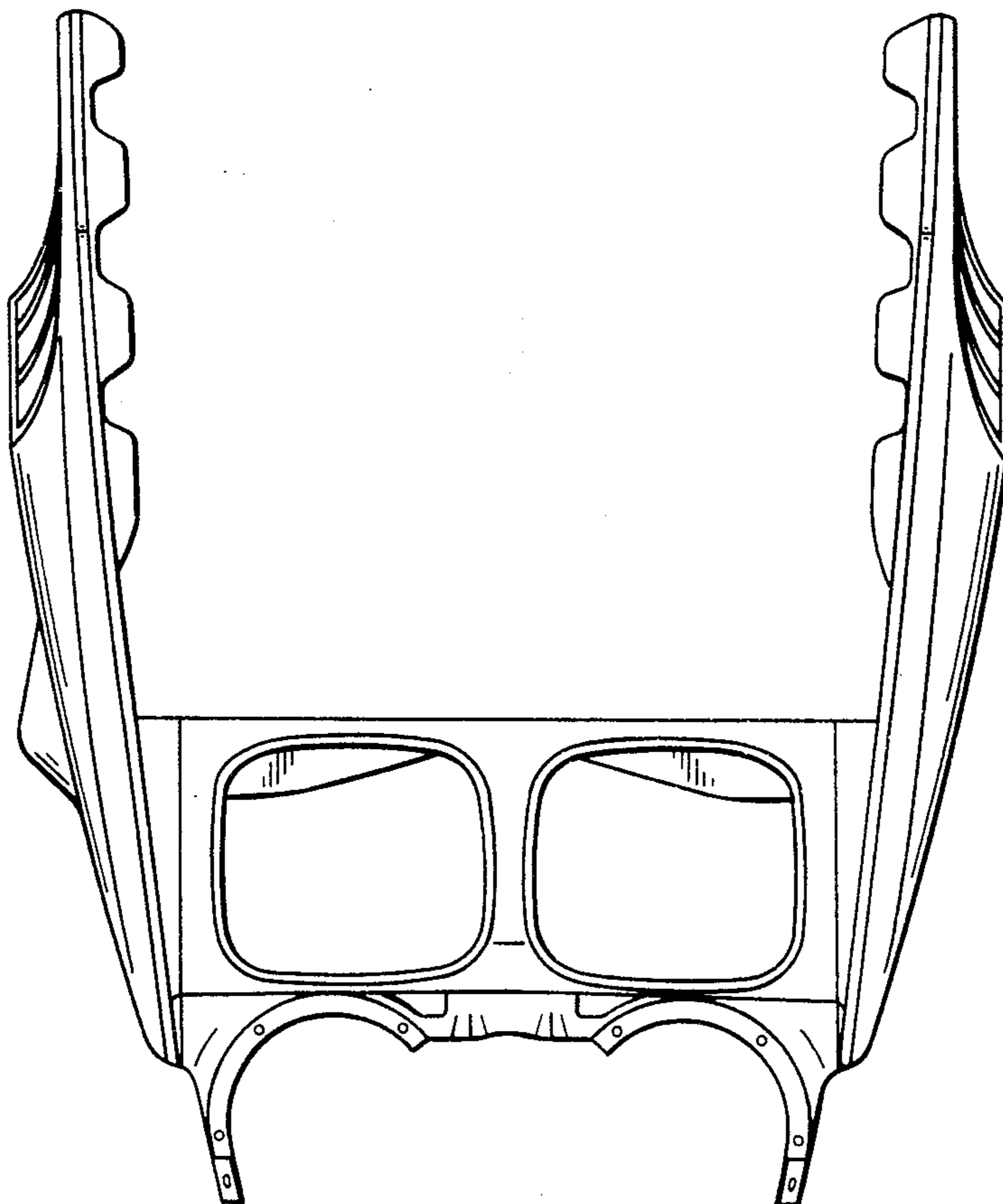

***Fig. 7***

