

[54] **VEHICLE WHEEL CENTER**

[75] **Inventor: Raymond J. Hedlund, Concord, Calif.**

[73] **Assignee: Kelsey-Hayes Company, Romulus, Mich.**

[**] **Term: 14 Years**

[21] **Appl. No.: 315,806**

[22] **Filed: Oct. 28, 1981**

[52] **U.S. Cl. D12/211**

[58] **Field of Search D12/209, 211; 301/63 R, 301/63 PW, 64 R, 64 SD, 65, 37 R**

[56] **References Cited**

U.S. PATENT DOCUMENTS

- D. 219,013 10/1970 Mitchell D12/211
- D. 230,726 3/1974 Cravits D12/211
- D. 256,456 8/1980 Blanchard D12/211

OTHER PUBLICATIONS

Product Engineering, 5/78, p. 44, Wheel, top right side of page.

Primary Examiner—James M. Gandy.
Attorney, Agent, or Firm—Ralph J. Skinkiss; David L. Kuhn

[57] **CLAIM**

The ornamental design for a vehicle wheel center, as shown and described.

DESCRIPTION

FIG. 1 is a perspective view of a vehicle wheel center showing my new design, it being understood that the broken lines are for illustrative purposes only; FIG. 2 is a front elevational view thereof; FIG. 3 is a sectional view taken along line 3—3 in FIG. 2; FIG. 4 is a sectional view taken along line 4—4 in FIG. 2; FIG. 5 is a sectional view taken along line 5—5 in FIG. 2; FIG. 6 is a sectional view taken along line 6—6 in FIG. 2; FIG. 7 is a perspective view of a vehicle wheel center showing a second embodiment of my design wherein the sole difference resides in the shape of the bolt holes, it being understood that the broken lines are for illustrative purposes only.

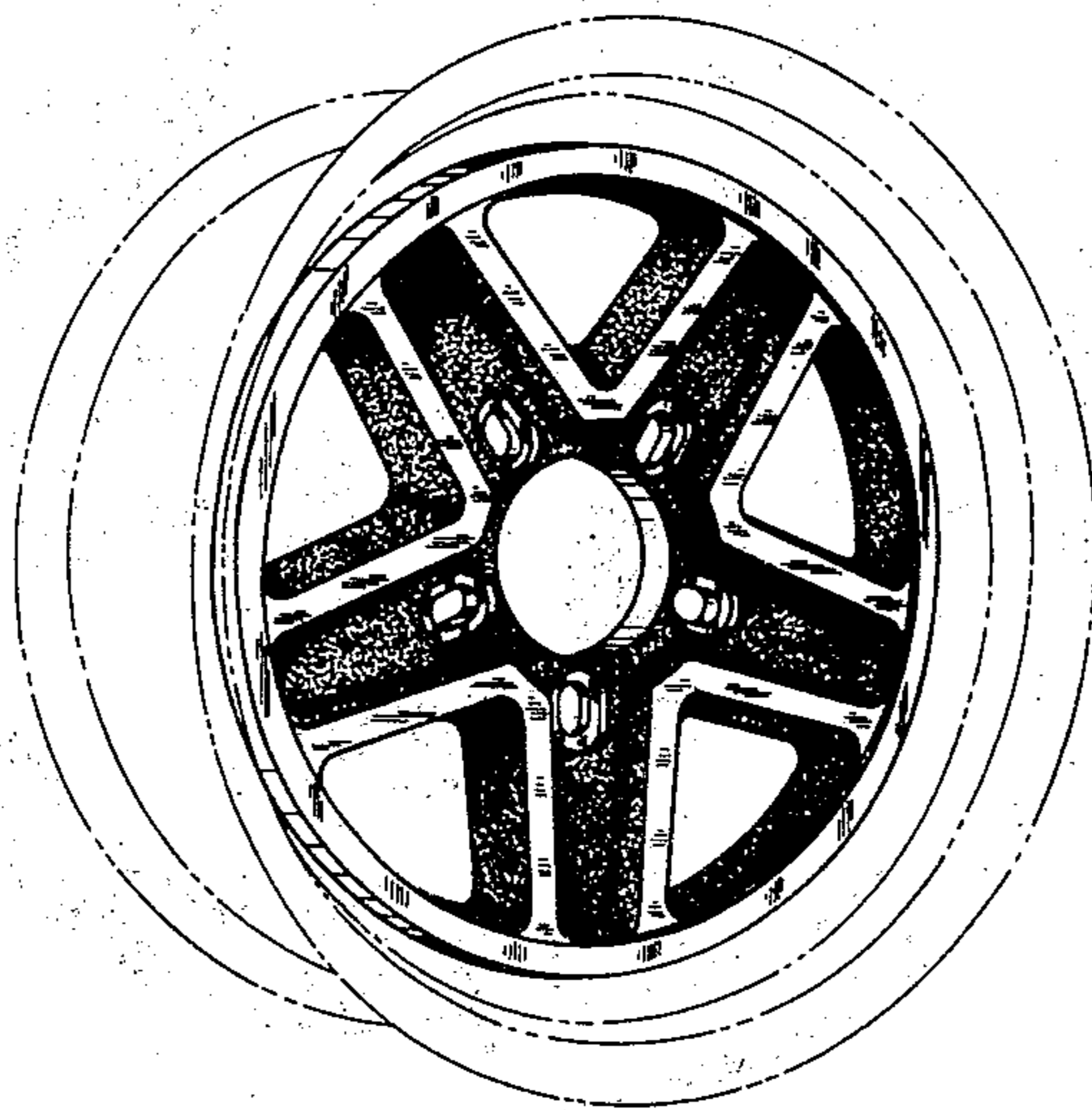

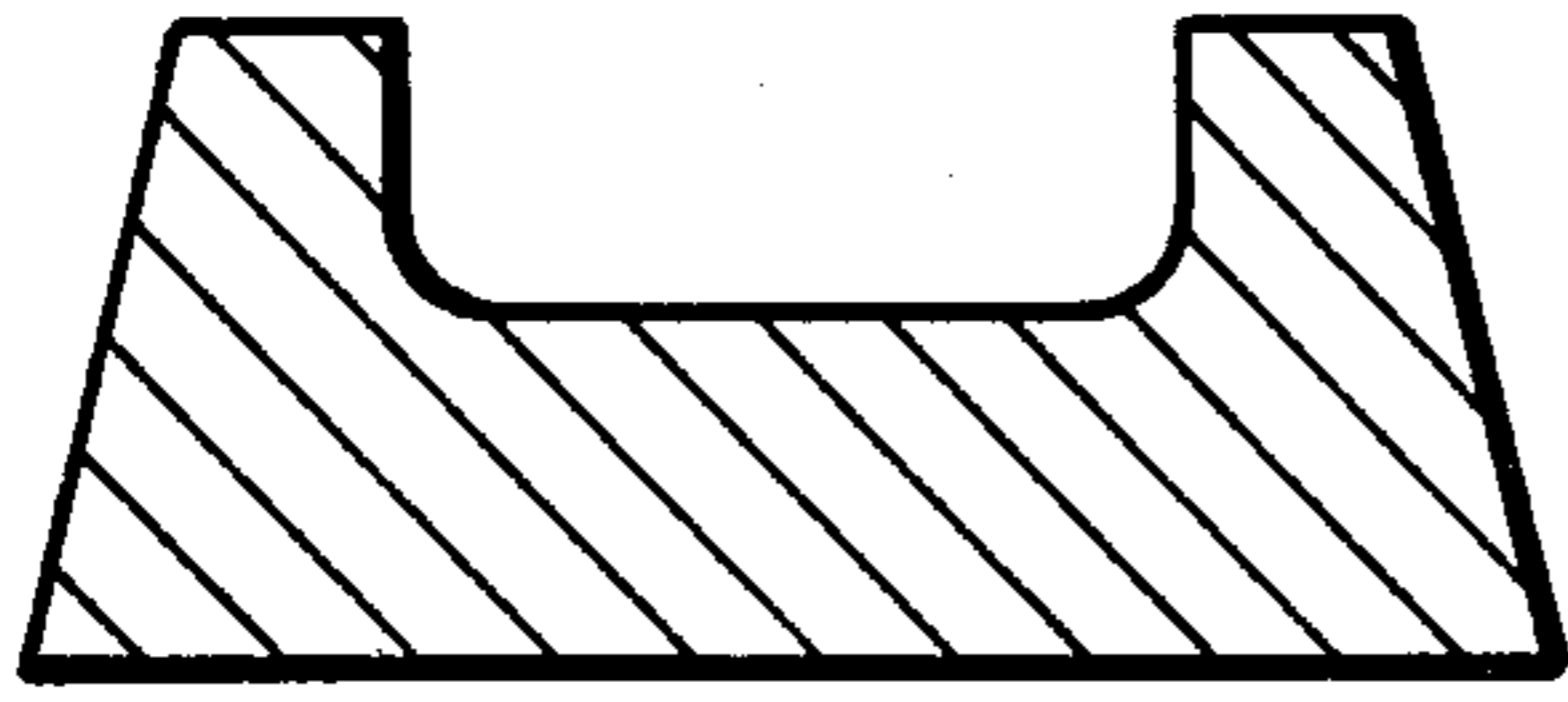

—FIG. 5

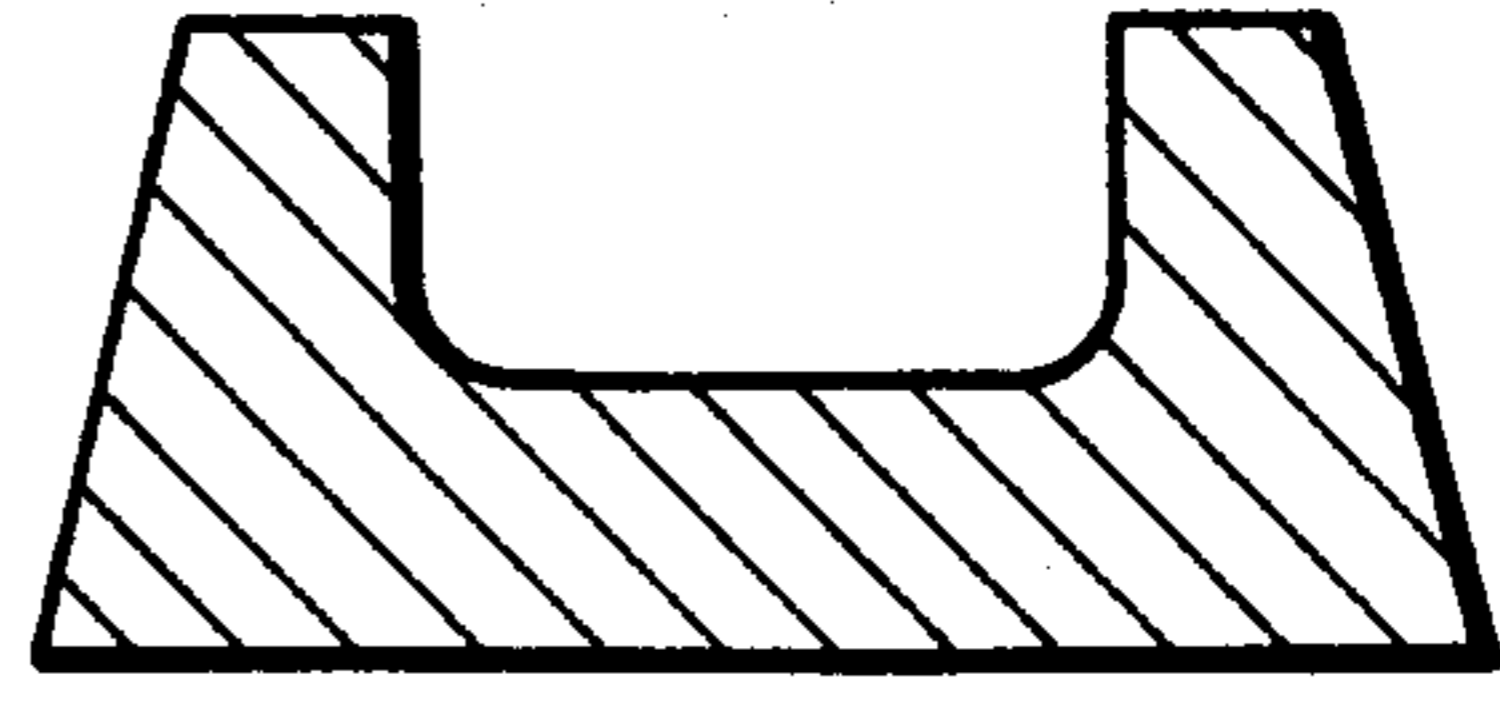

—FIG. 6

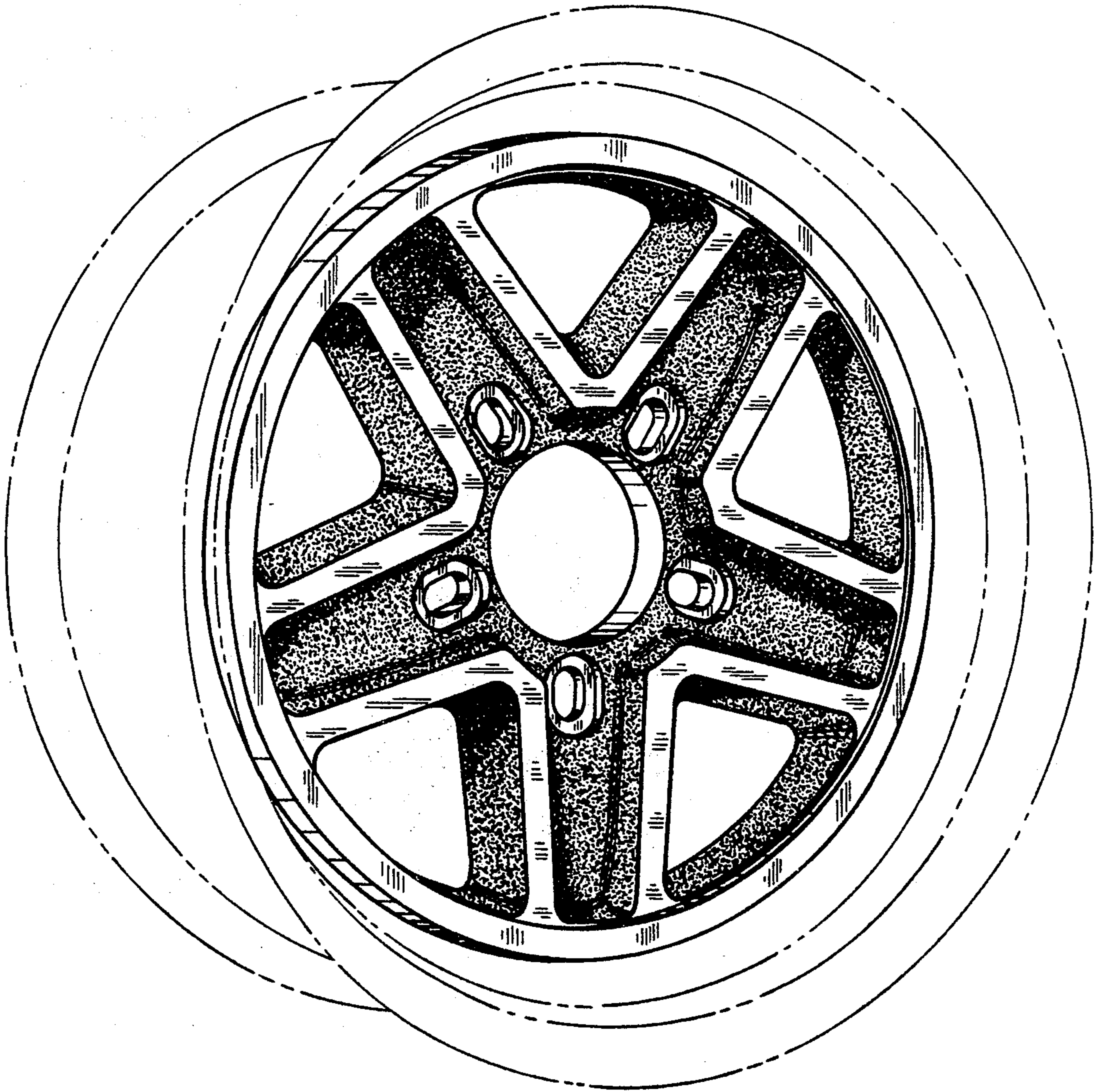

—FIG. 1

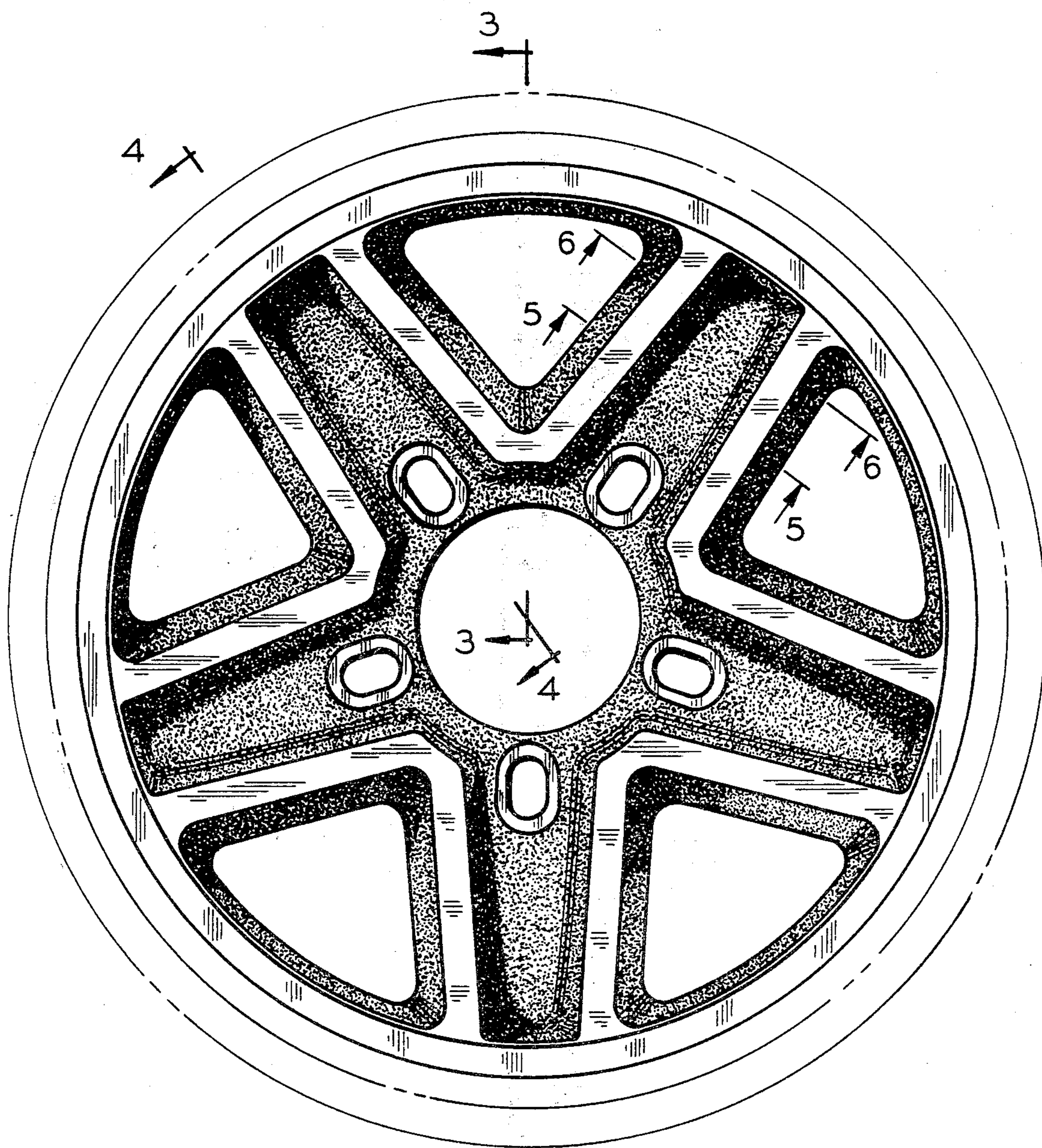

—FIG. 2

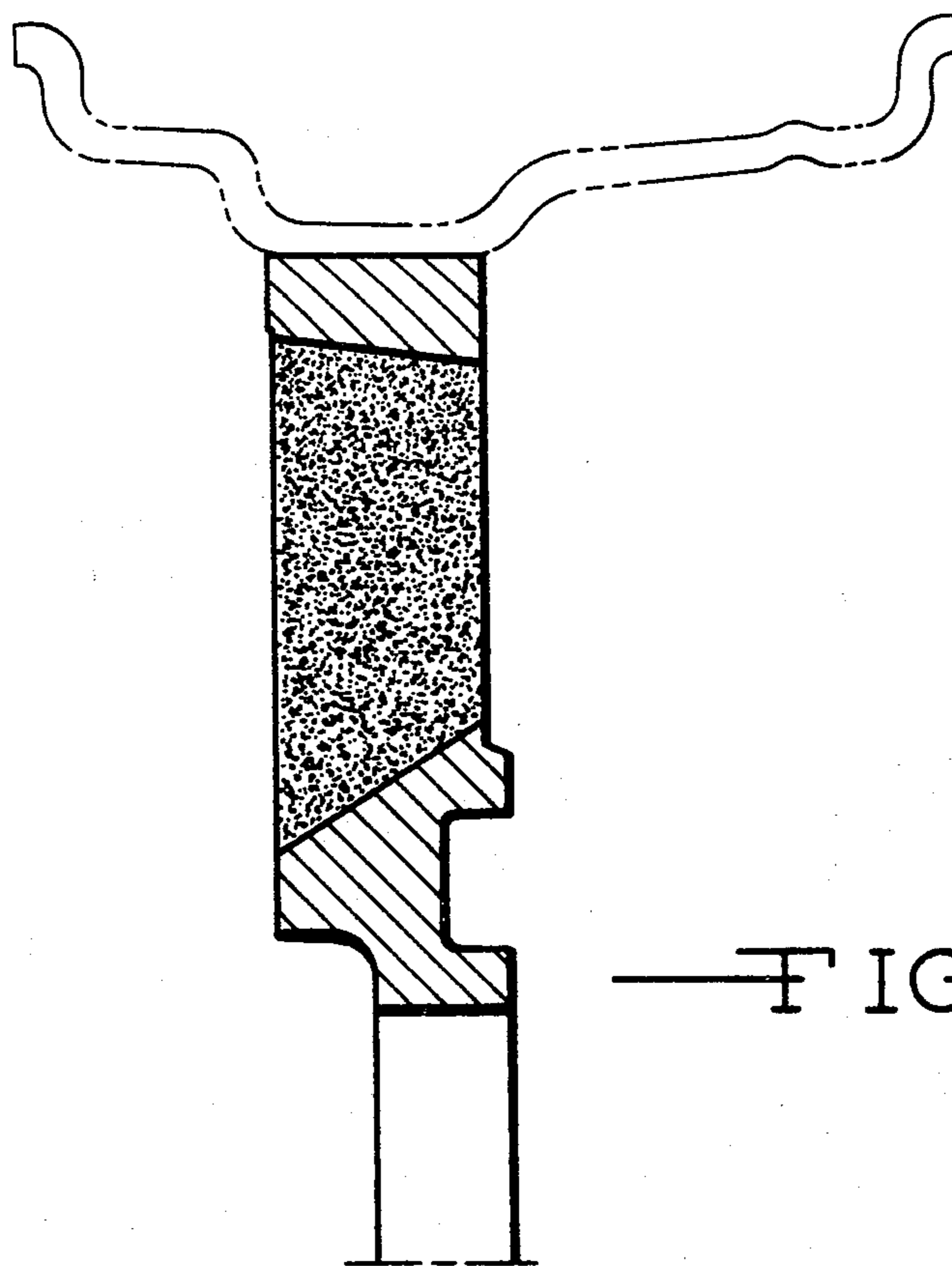

— FIG. 3

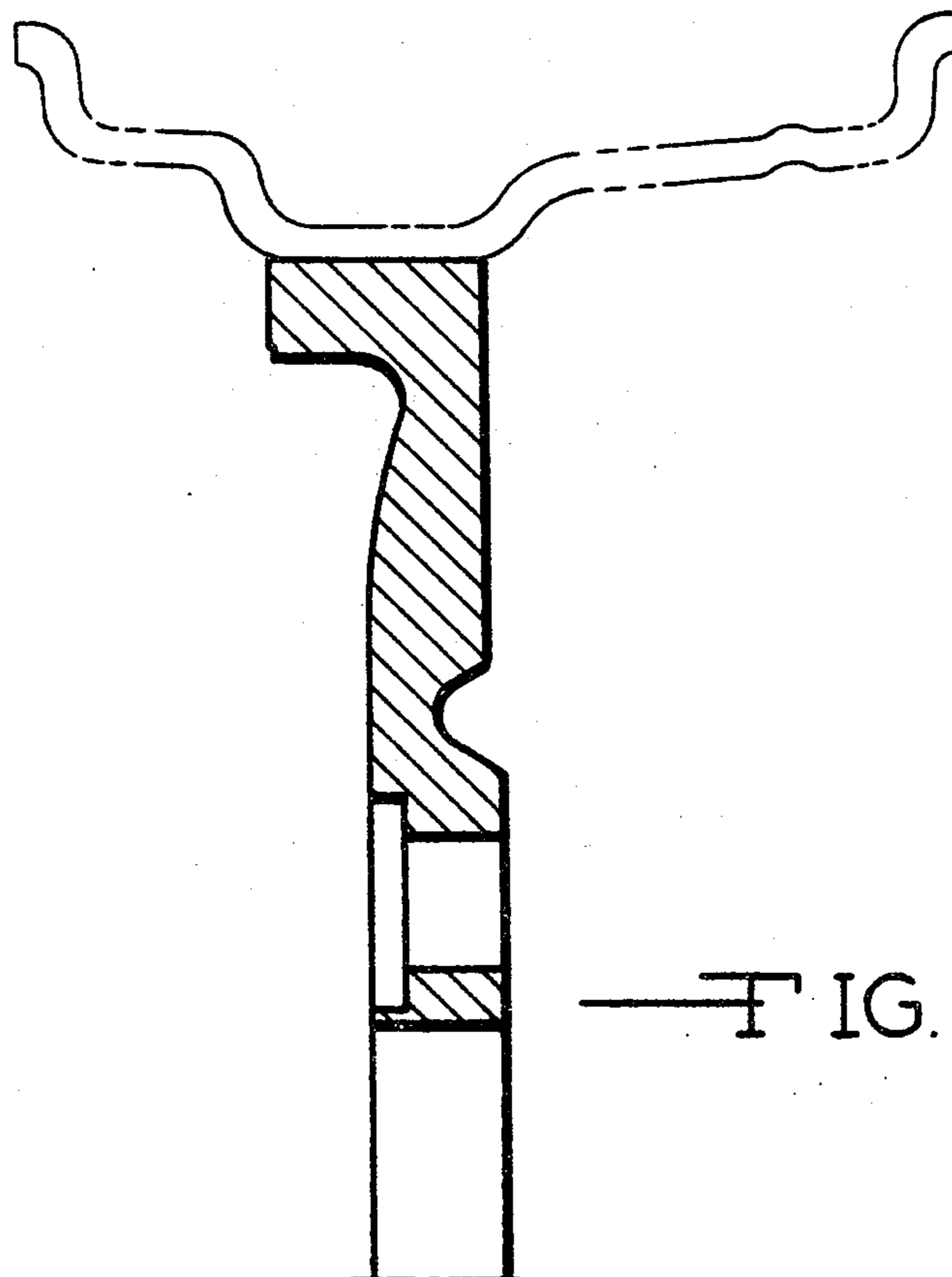

— FIG. 4

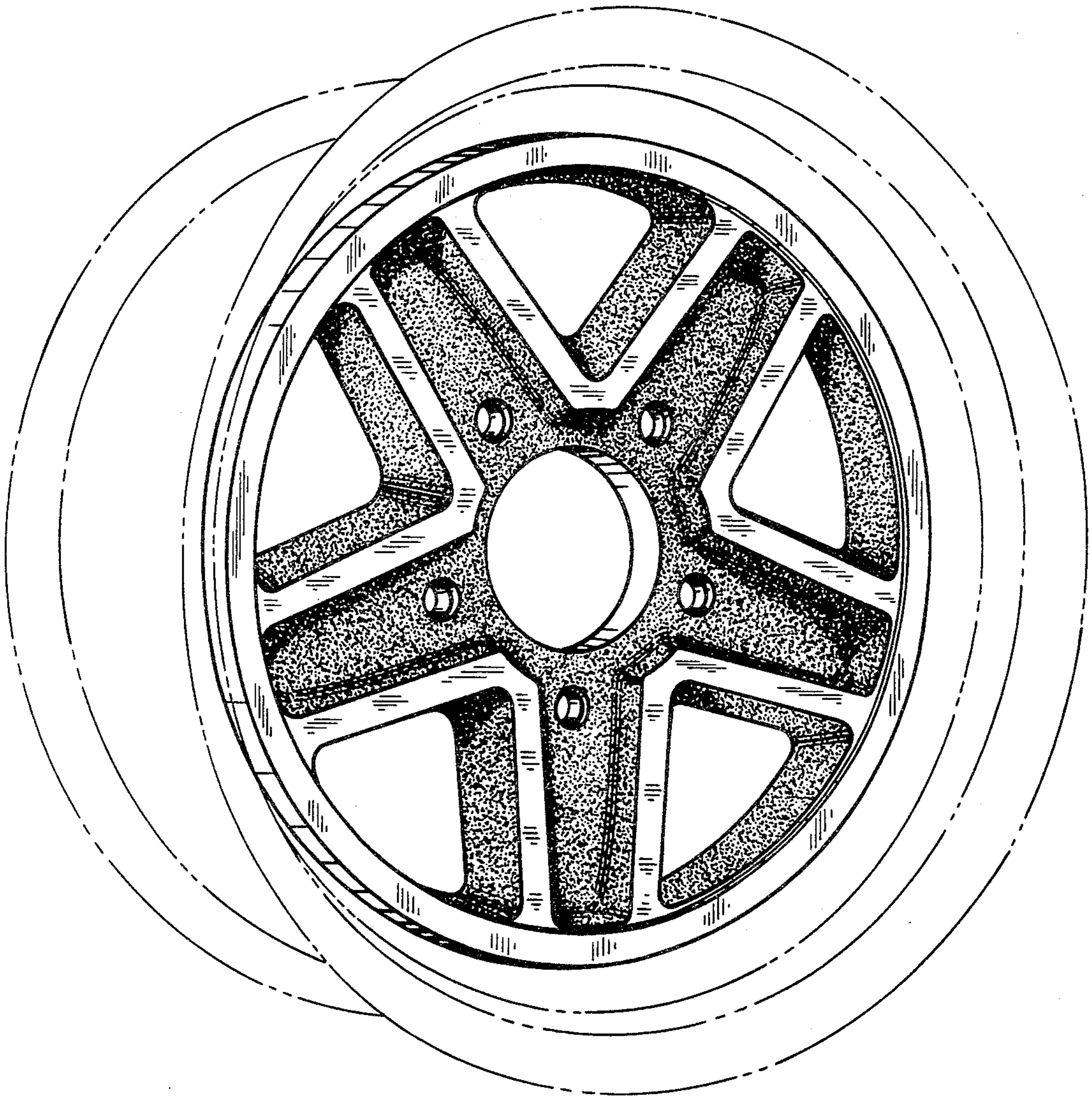

—FIG. 7