

[54] **UPPER FAIRING FOR MOTORCYCLES**

[75] **Inventor: Karl H. Abe, Steinebach/Wörthsee, Fed. Rep. of Germany**

[73] **Assignee: Bayerische Motoren Werke AG, Fed. Rep. of Germany**

[\*\*] **Term: 14 Years**

[21] **Appl. No.: 544,290**

[22] **Filed: Oct. 21, 1983**

[30] **Foreign Application Priority Data**

Apr. 22, 1983 [DE] Fed. Rep. of Germany ... MR 13423  
[52] **U.S. Cl. .... D12/182**  
[58] **Field of Search ..... D12/182; 296/78.1; 280/289 S**

[56] **References Cited PUBLICATIONS**

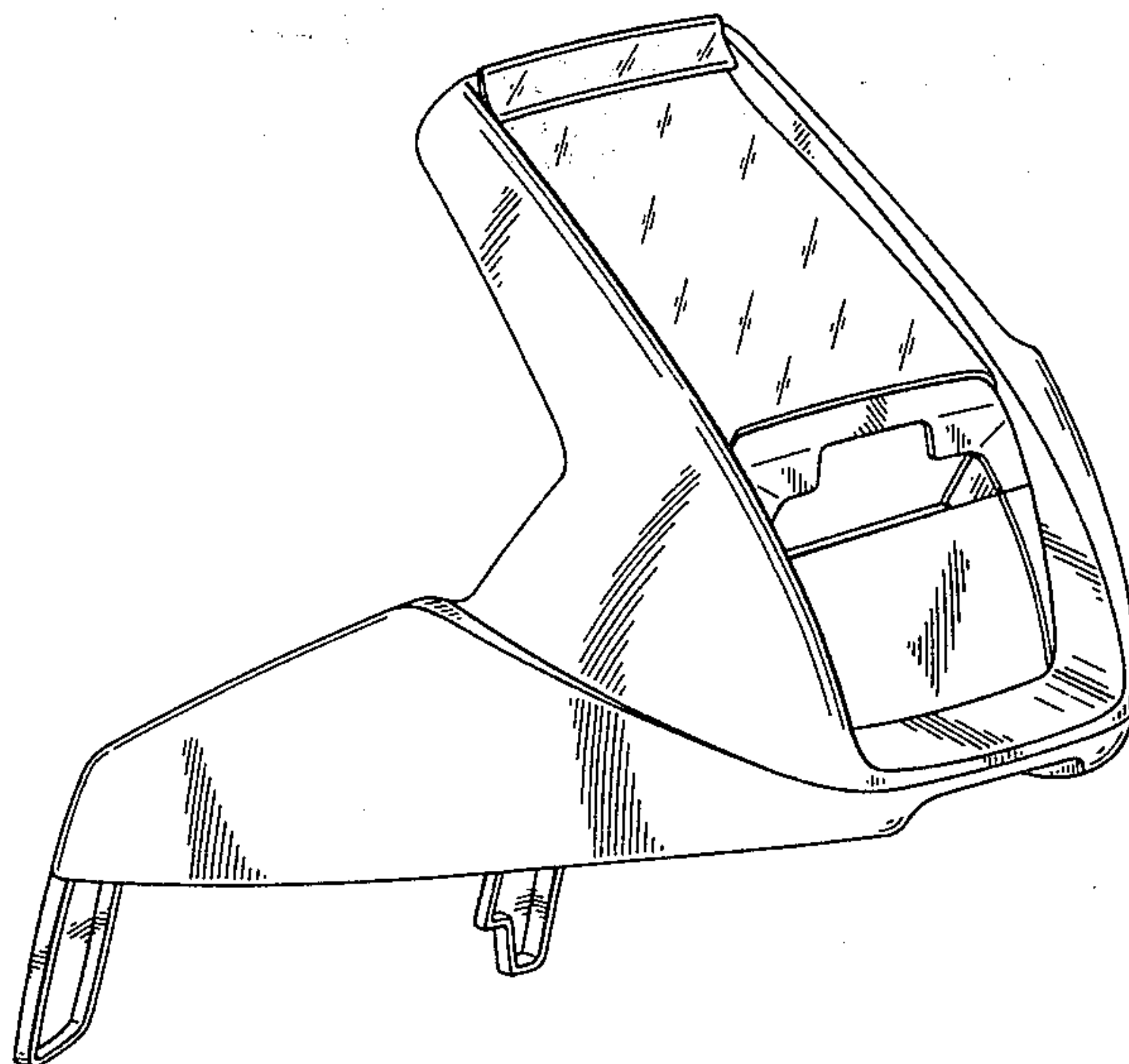
Cycle World, 2/82, p. 63, Suzuki Fairing, center left side of page.  
Cycle World, 11/76, p. 29, BMW R100RS Fairing, top of page.  
*Primary Examiner*—James M. Gandy  
*Attorney, Agent, or Firm*—Craig & Burns

[57] **CLAIM**

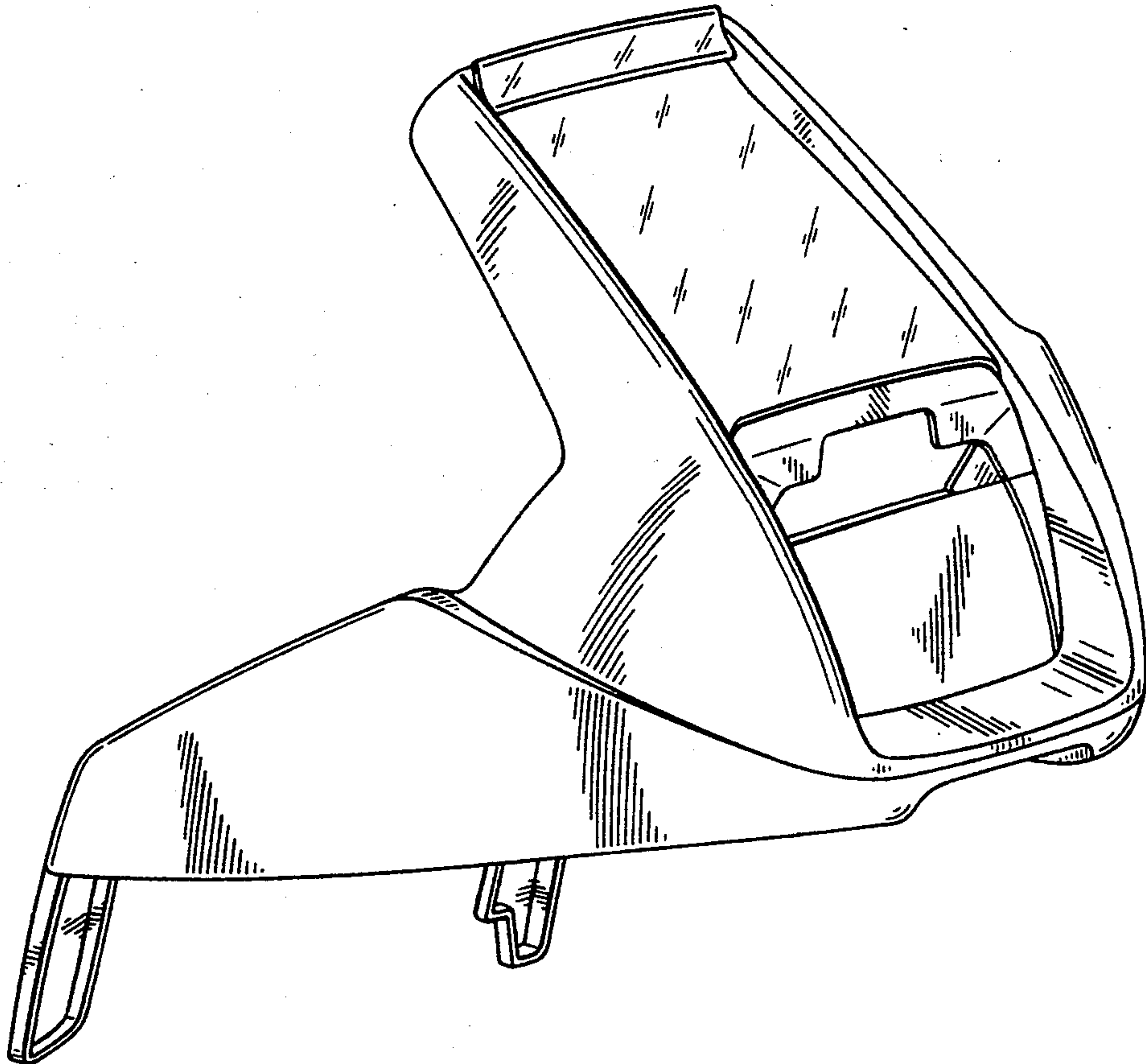
The ornamental design for an upper fairing for motorcycles, as shown and described.

**DESCRIPTION**

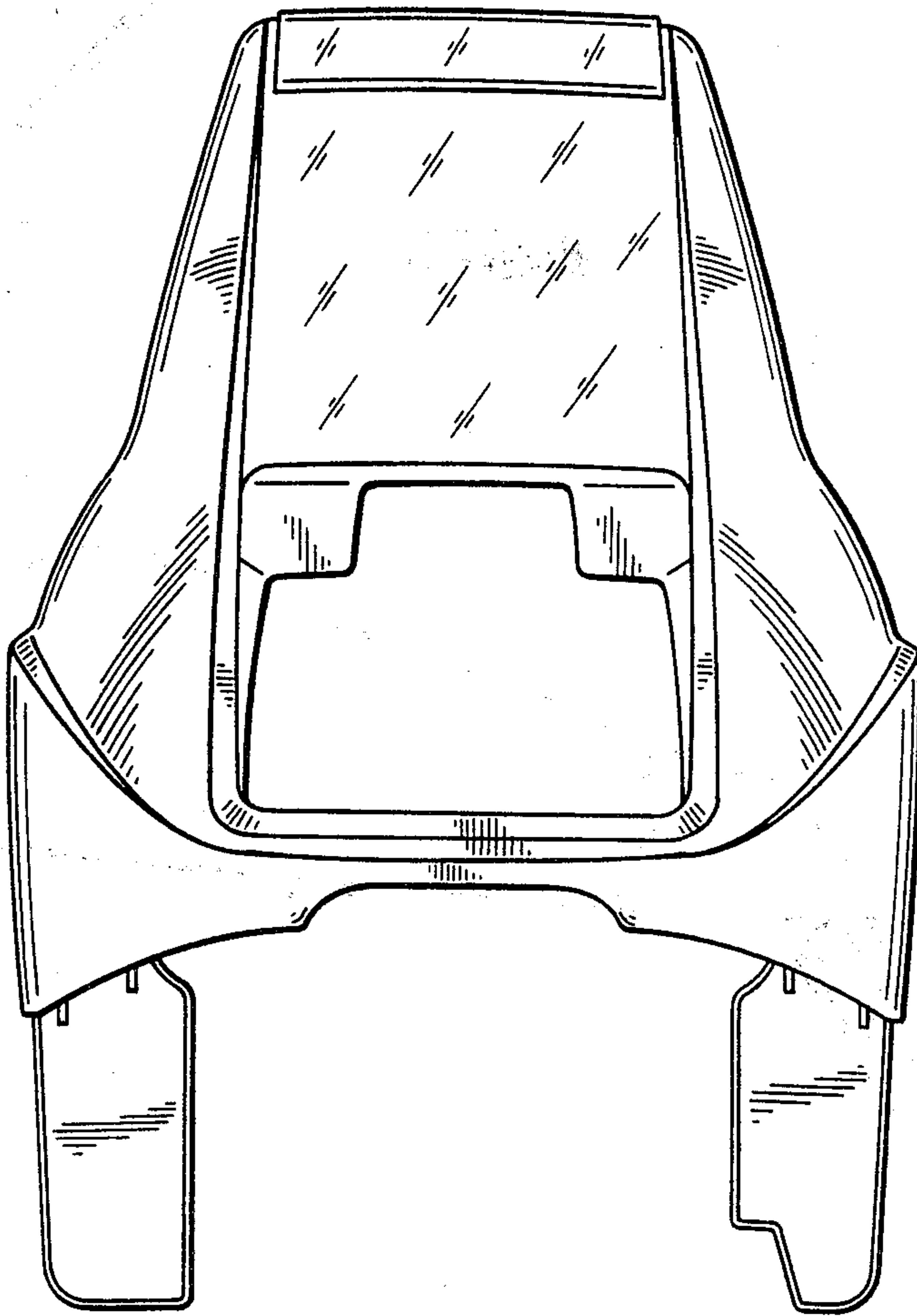
FIG. 1 is a perspective view from one side of the front and above of the upper fairing for motorcycles embodying my novel design;  
FIG. 2 is a front elevation view thereof;  
FIG. 3 is an elevation view from one side thereof;  
FIG. 4 is an elevation view from the other side thereof;  
FIG. 5 is a rear elevation view thereof;  
FIG. 6 is a top plan view thereof; and  
FIG. 7 is a bottom plan view thereof.



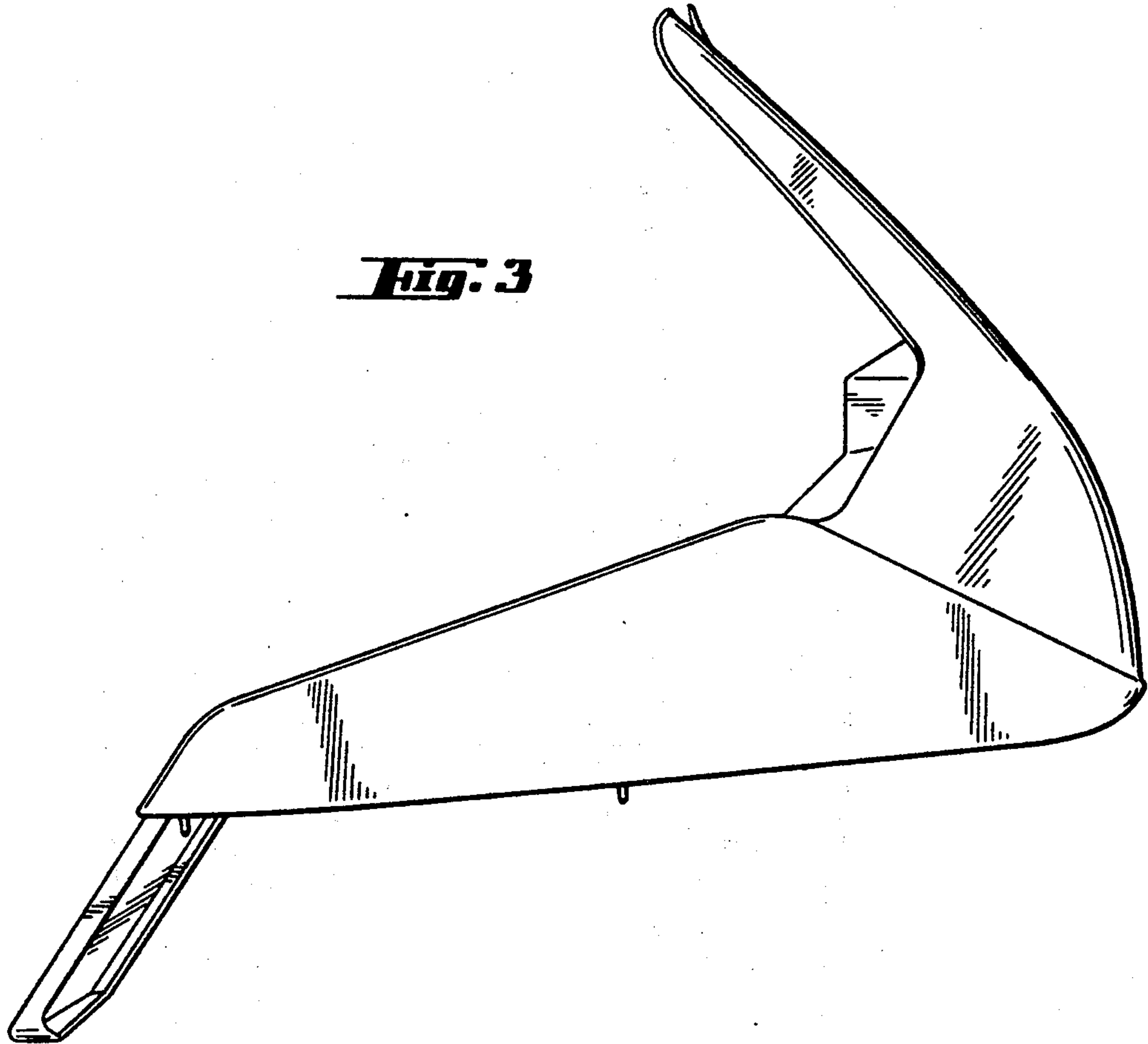
***Fig. 1***

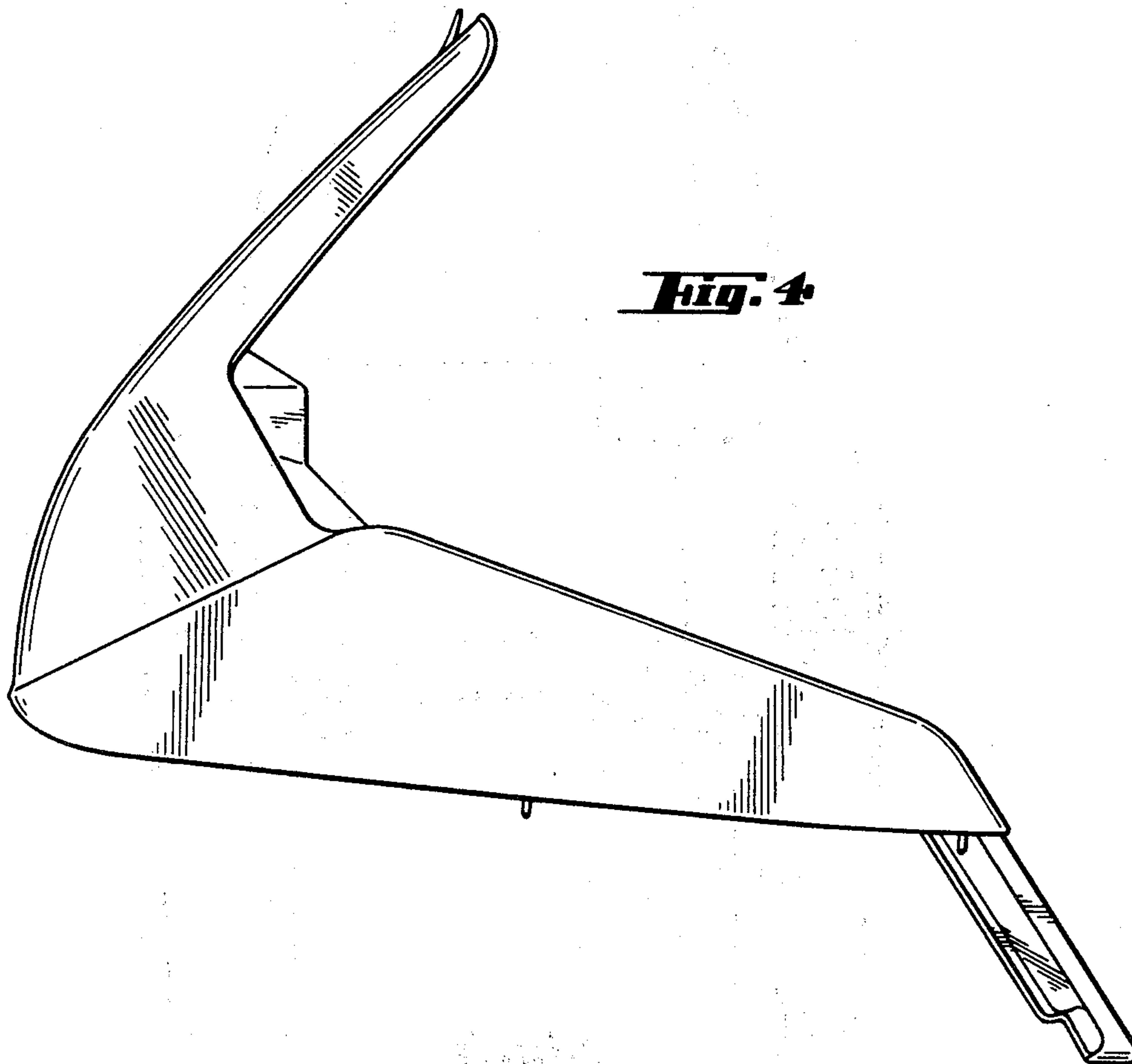


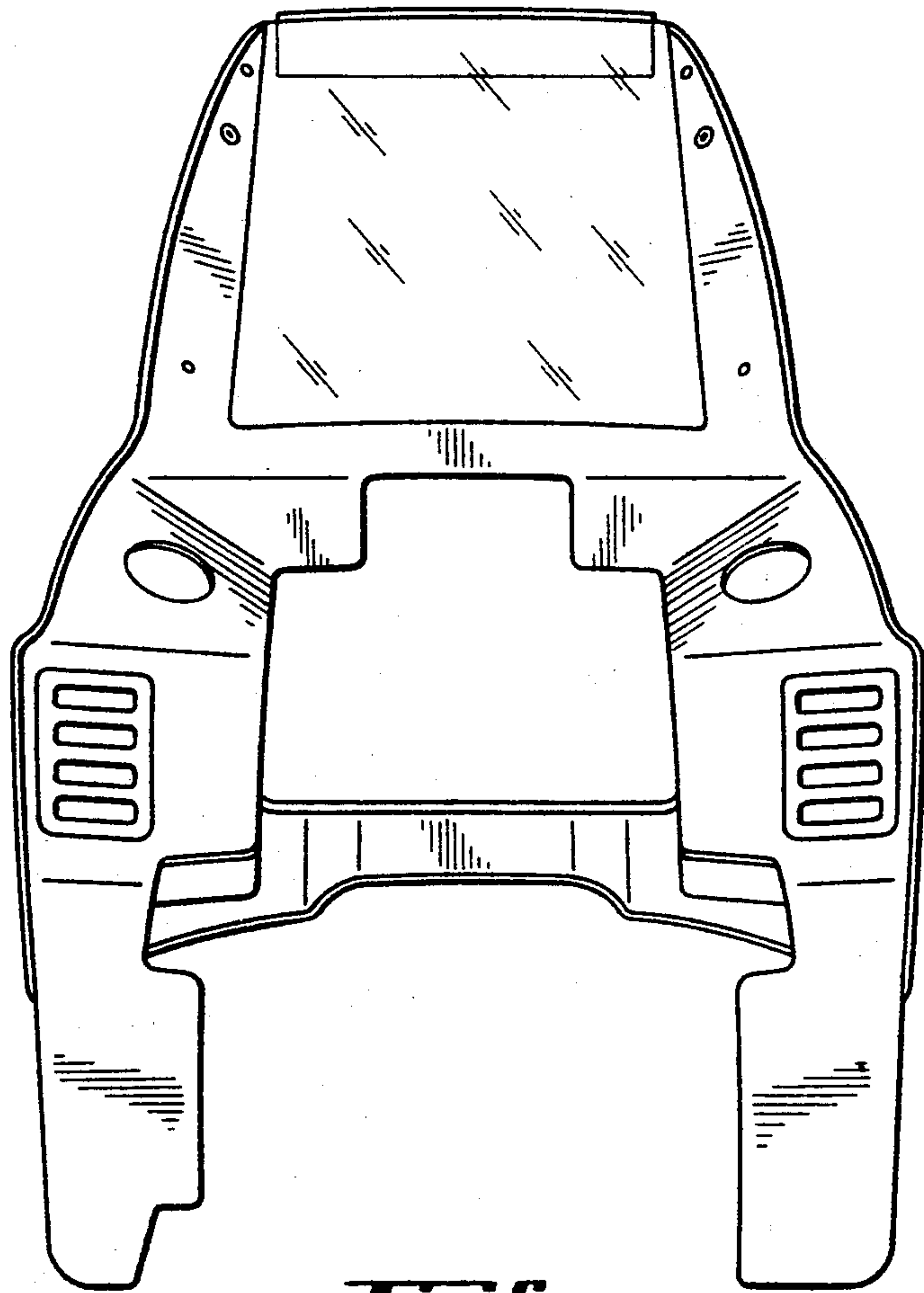
**Fig. 2**



***Fig. 3***

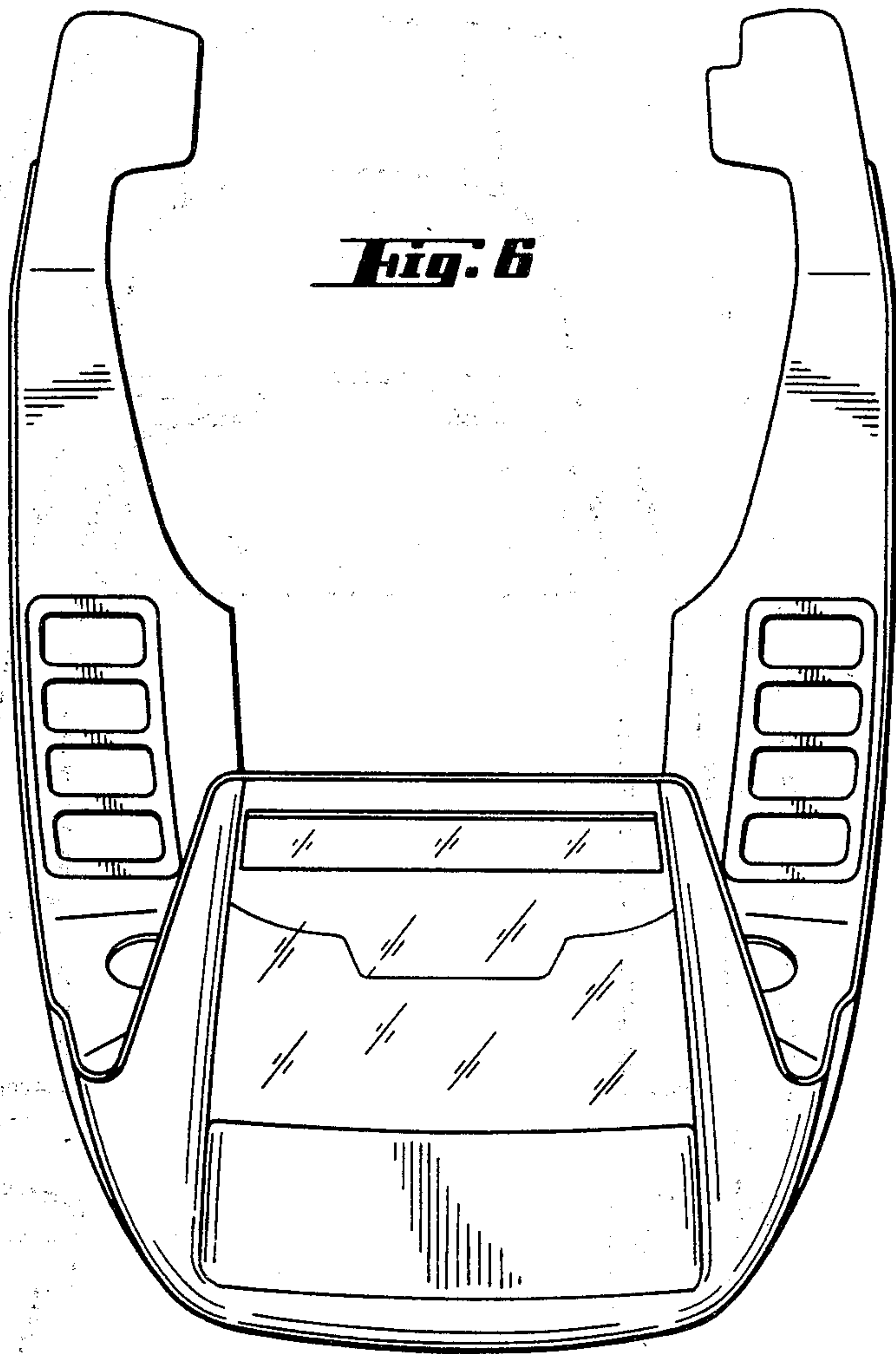






**Fig. 5**





***Fig. 7***

