

[54] ROOF-TOP AIR CONDITIONER CABINET FOR A VEHICLE

[75] Inventor: William H. Armstrong, Troy, Mich.

[73] Assignee: The Duo-Therm Corporation, Del.

[**] Term: 14 Years

[21] Appl. No.: 635,622

[22] Filed: Jul. 30, 1984

[52] U.S. Cl. D23/142

[58] Field of Search D23/139-167, D23/42, 83, 90, 111-119; D12/93, 95-96; D62/3; 296/15, 91; 62/239, 241-244, 263; 98/2, 2.11, 2.14, 2.16-2.17, 36-39, 42, 42.21, 94, 103, 114, 115.1-115.4

[56] References Cited

U.S. PATENT DOCUMENTS

D. 213,559	3/1969	Baugh et al.	D23/142
4,261,930	4/1981	Walker	98/2.14
4,492,151	1/1985	Mattei	98/2.11

OTHER PUBLICATIONS

Recreational Vehicle Dealer (Feb. 1973) "Insta-matic" Advertisement, p. 95.

Recreational Vehicle Dealer (Sep. 1974) "Air Conditioning Service, Maintenance and Repairs", p. 62.

Primary Examiner—Wallace R. Burke

Assistant Examiner—Brian N. Vinson

Attorney, Agent, or Firm—Barnes, Kisselle, Raisch, Choate, Whittemore & Hulbert

[57] CLAIM

The ornamental design for a roof-top air conditioner cabinet for a vehicle, substantially as shown and described.

DESCRIPTION

FIG. 1 is a top perspective view of a roof-top air conditioner cabinet for a vehicle, showing my new design; FIG. 2 is a reversed bottom perspective view thereof; FIG. 3 is a top plan view thereof; FIG. 4 is a left side elevation thereof, the opposite side being identical; FIG. 5 is a bottom plan view thereof; FIG. 6 is a front end elevation thereof; and FIG. 7 is a rear end elevation thereof.

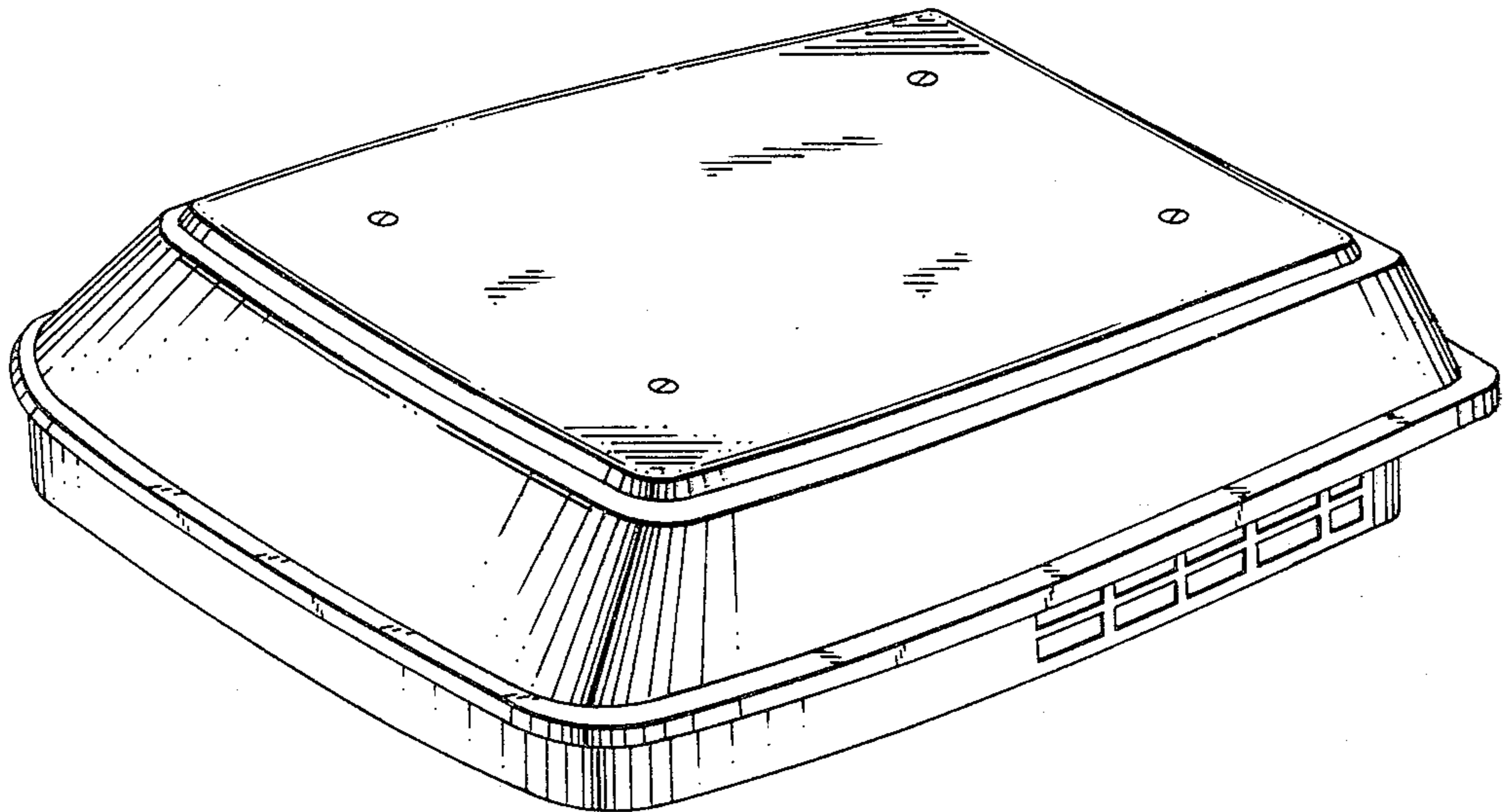

FIG. 1

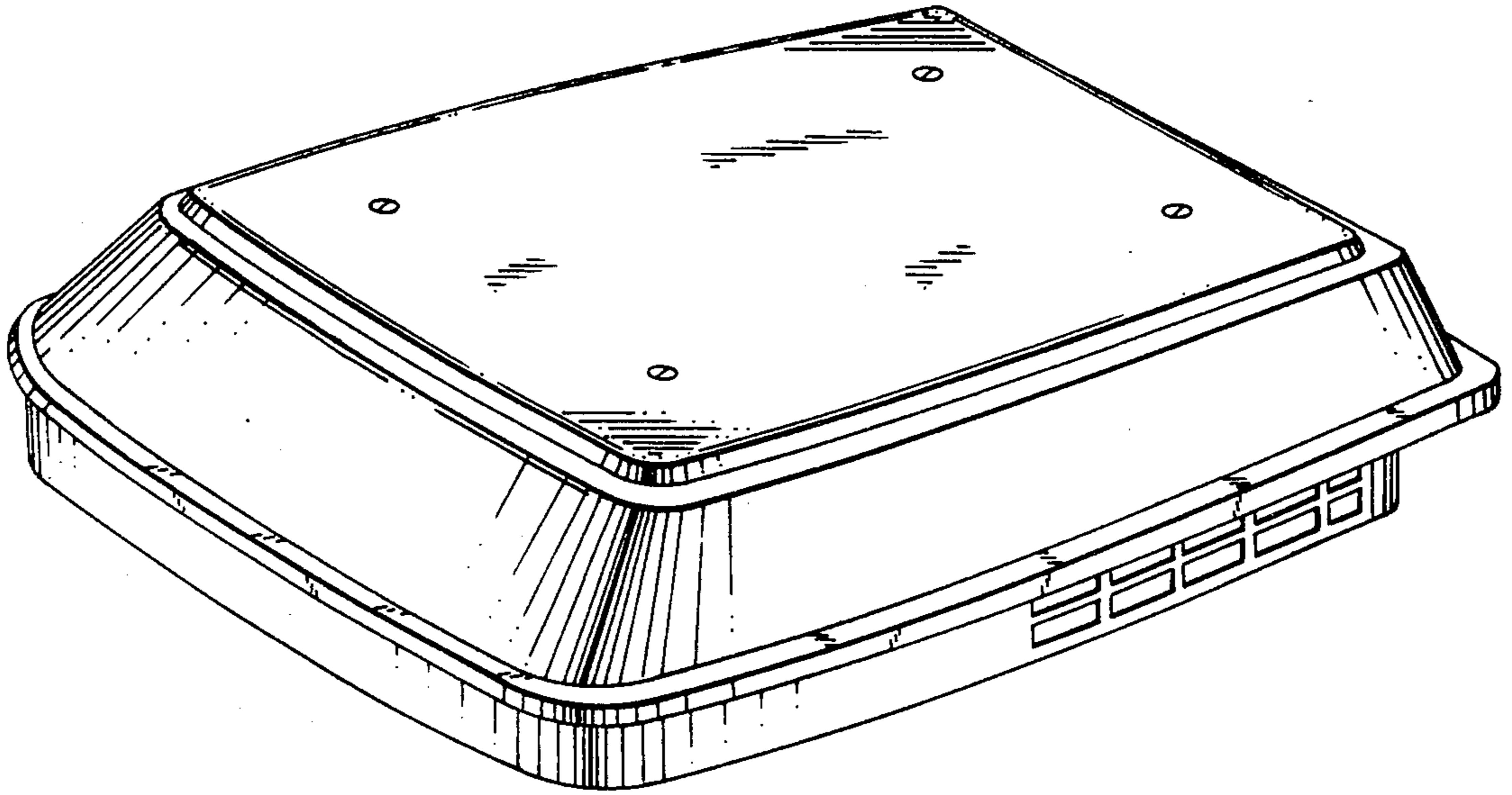

FIG. 2

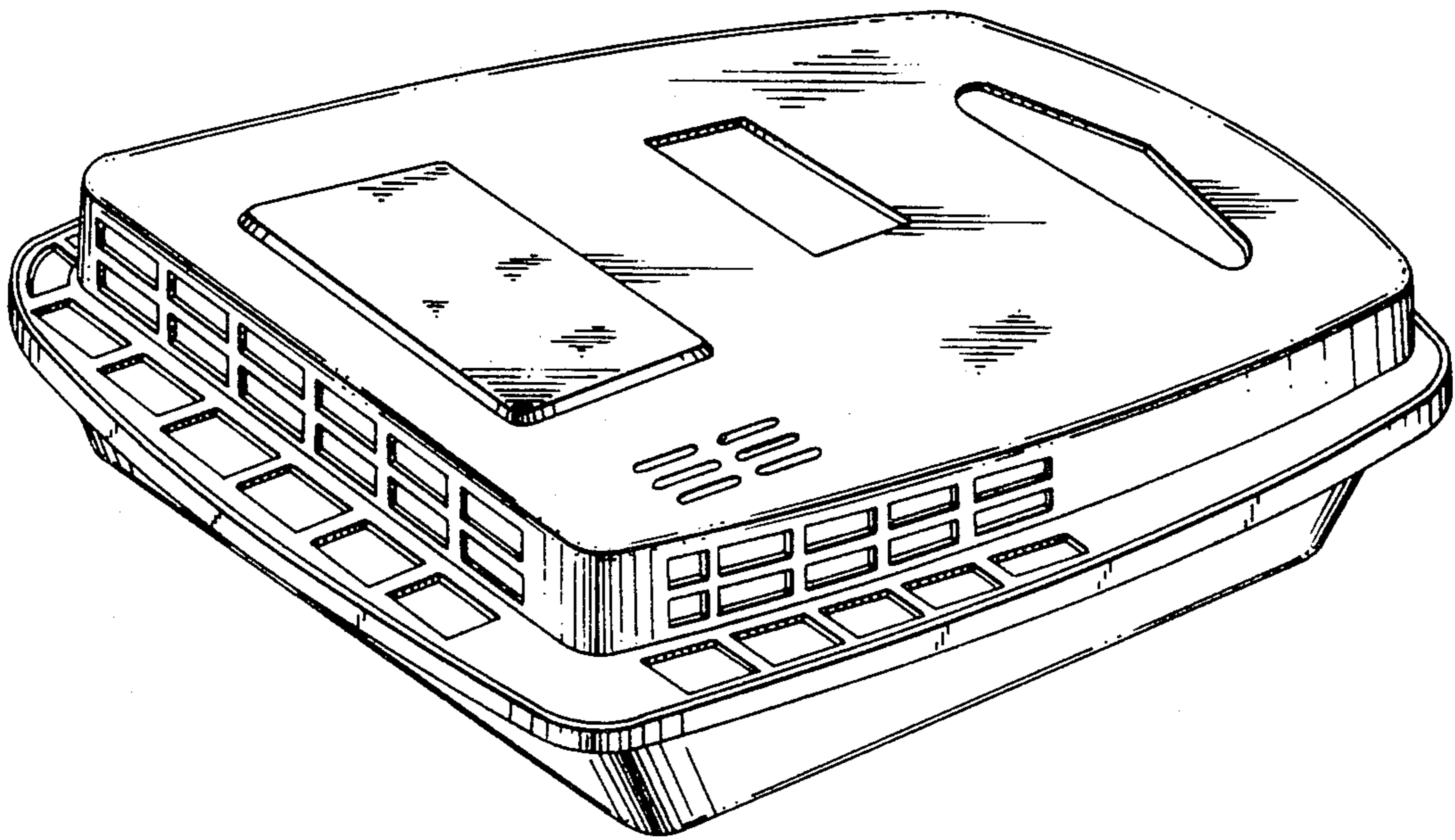

FIG. 6

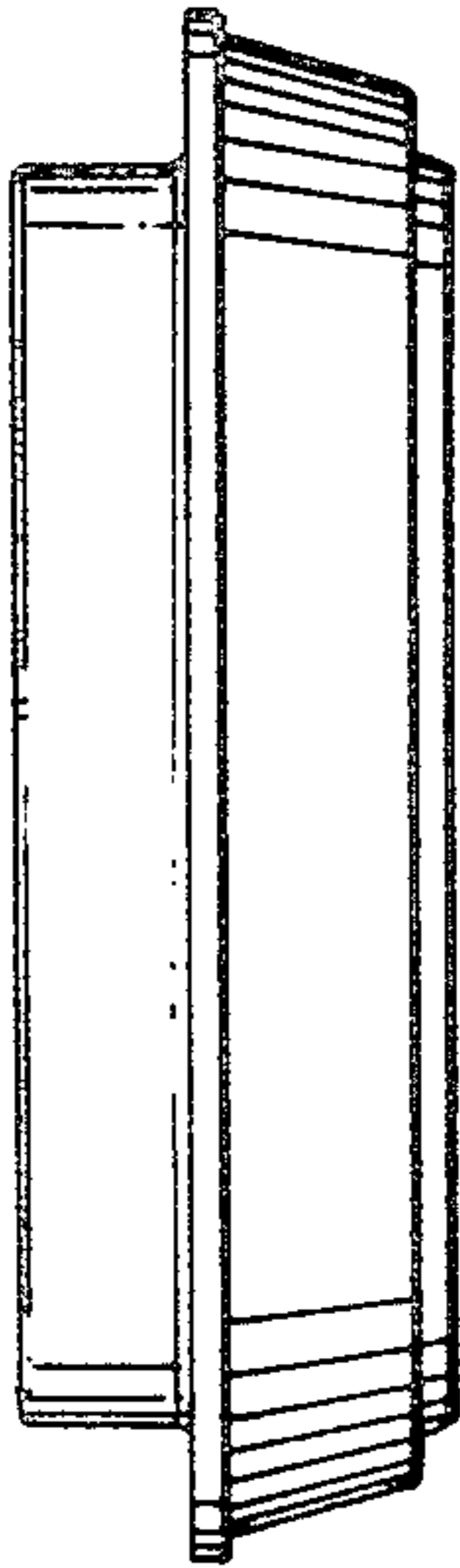

FIG. 3

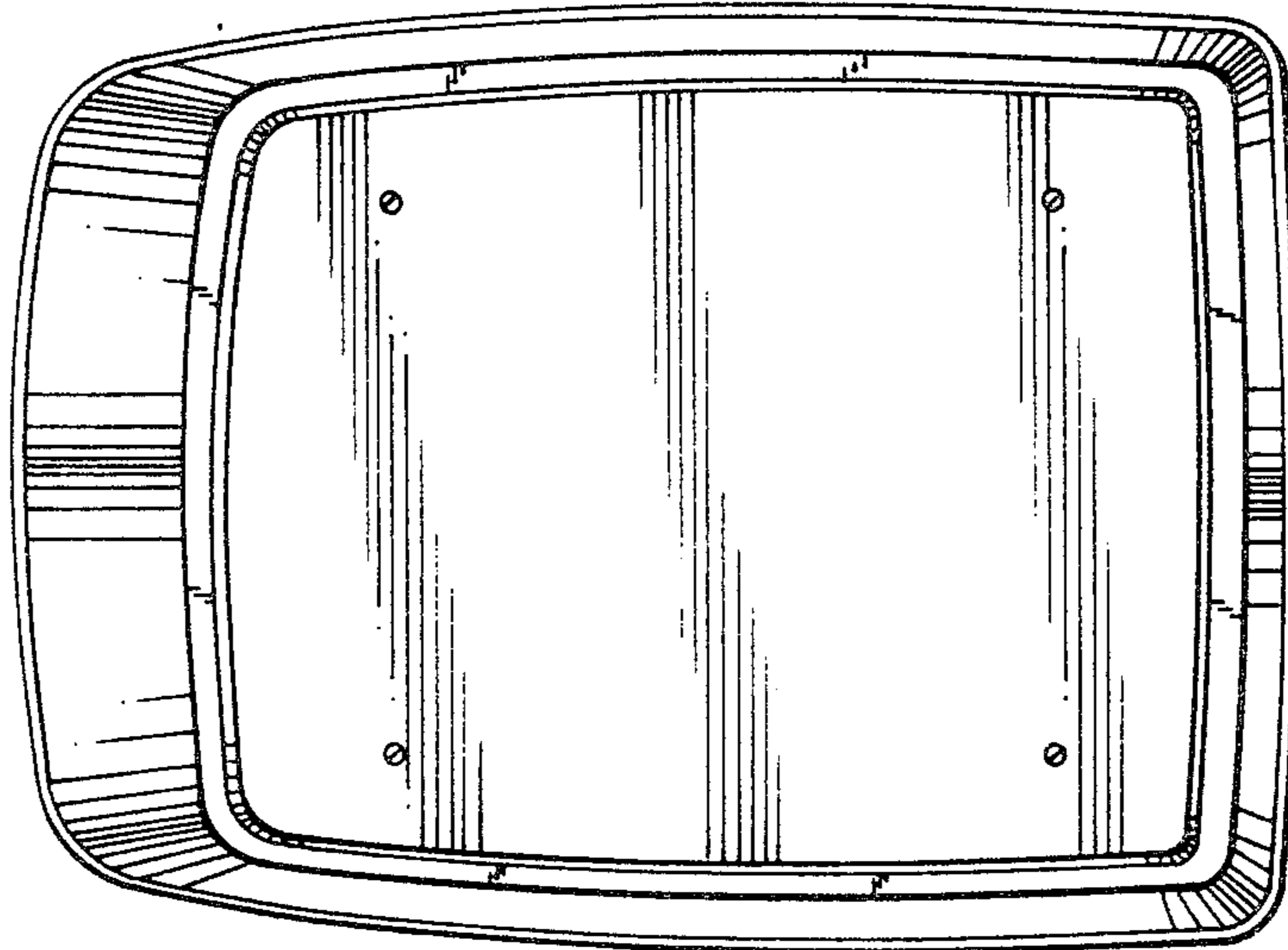

FIG. 7

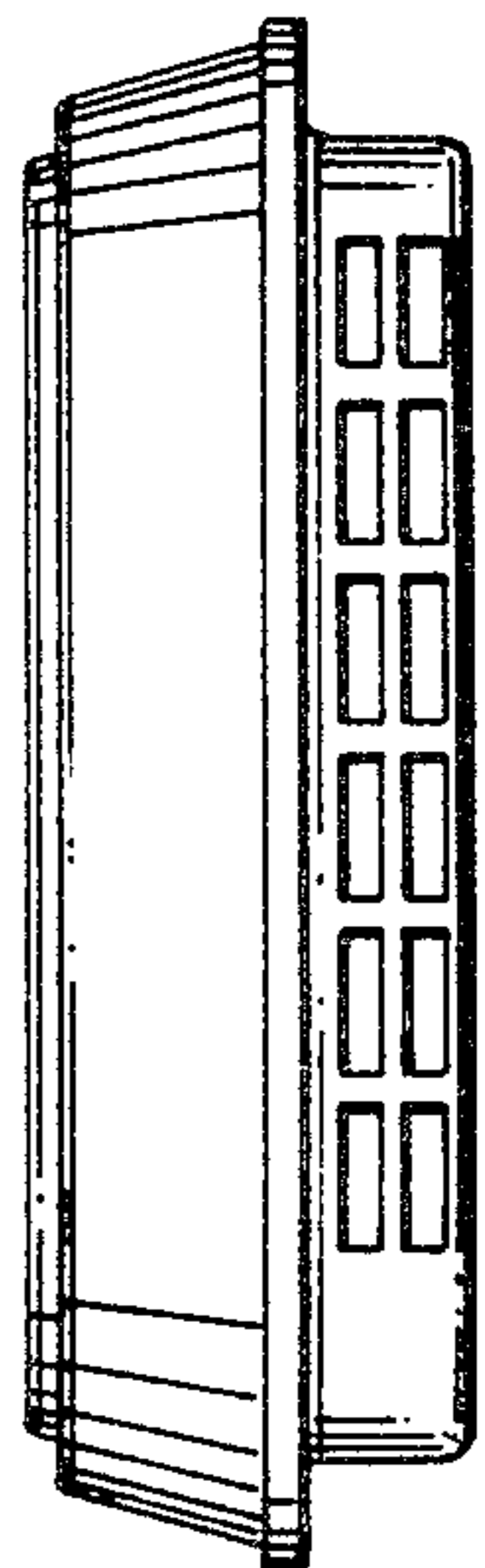

FIG. 4

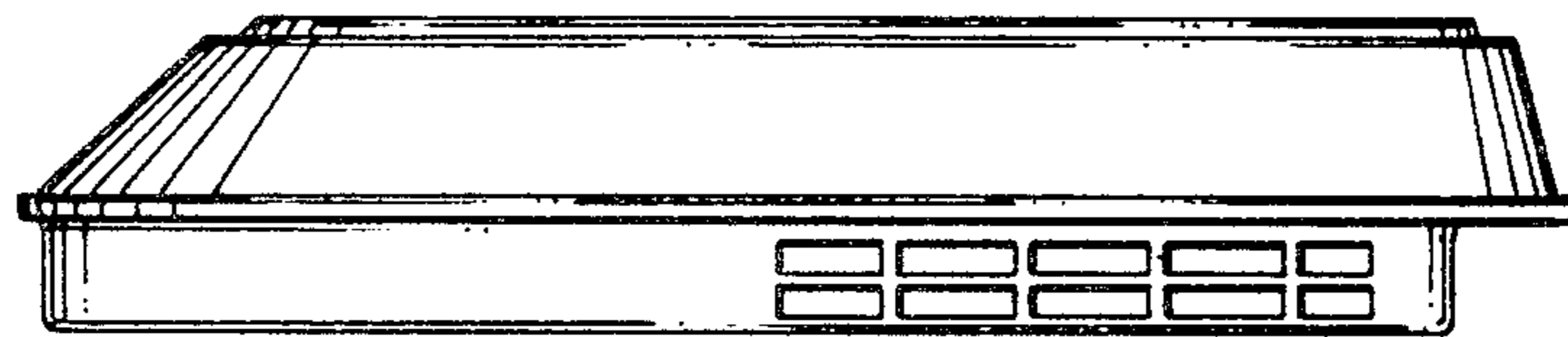

FIG. 5

