

[54] TOY VEHICLE CHASSIS

[75] Inventor: Fujio Arigaya, Tokyo, Japan

[73] Assignee: Takara Co., Ltd., Tokyo, Japan

[\*\*] Term: 14 Years

[21] Appl. No.: 549,664

[22] Filed: Nov. 7, 1983

[30] Foreign Application Priority Data

Apr. 10, 1983 [JP] Japan ..... 58-43095

[52] U.S. Cl. .... D21/141

[58] Field of Search ..... D21/71, 73, 74, 76, D21/78, 81, 128, 130, 134, 140, 136, 137, 141; 446/71, 72, 88, 93, 94, 95, 465, 469, 470, 471

[56] References Cited

U.S. PATENT DOCUMENTS

- D. 117,554 11/1939 Bojesen ..... D21/141
- D. 223,769 6/1972 Ruokonen ..... D21/128

- D. 225,761 1/1973 Munn et al. .... D21/134
- 2,382,982 8/1945 Elliott ..... 446/94
- 2,459,321 1/1949 Johnson ..... 446/95
- 2,568,557 9/1951 Newbery ..... 446/72
- 3,711,989 1/1973 Nielsen ..... 446/469

Primary Examiner—Charles A. Rademaker  
Attorney, Agent, or Firm—Price, Gess & Ubell

[57] CLAIM

The ornamental design for a toy vehicle chassis, substantially as shown and described.

DESCRIPTION

FIG. 1 is a front side perspective view of a toy vehicle chassis showing my new design;  
FIG. 2 is a top plan view;  
FIG. 3 is a right side elevational view, the side opposite being substantially a mirror image;  
FIG. 4 is a front elevational view;  
FIG. 5 is a rear elevational view; and  
FIG. 6 is a bottom plan view.

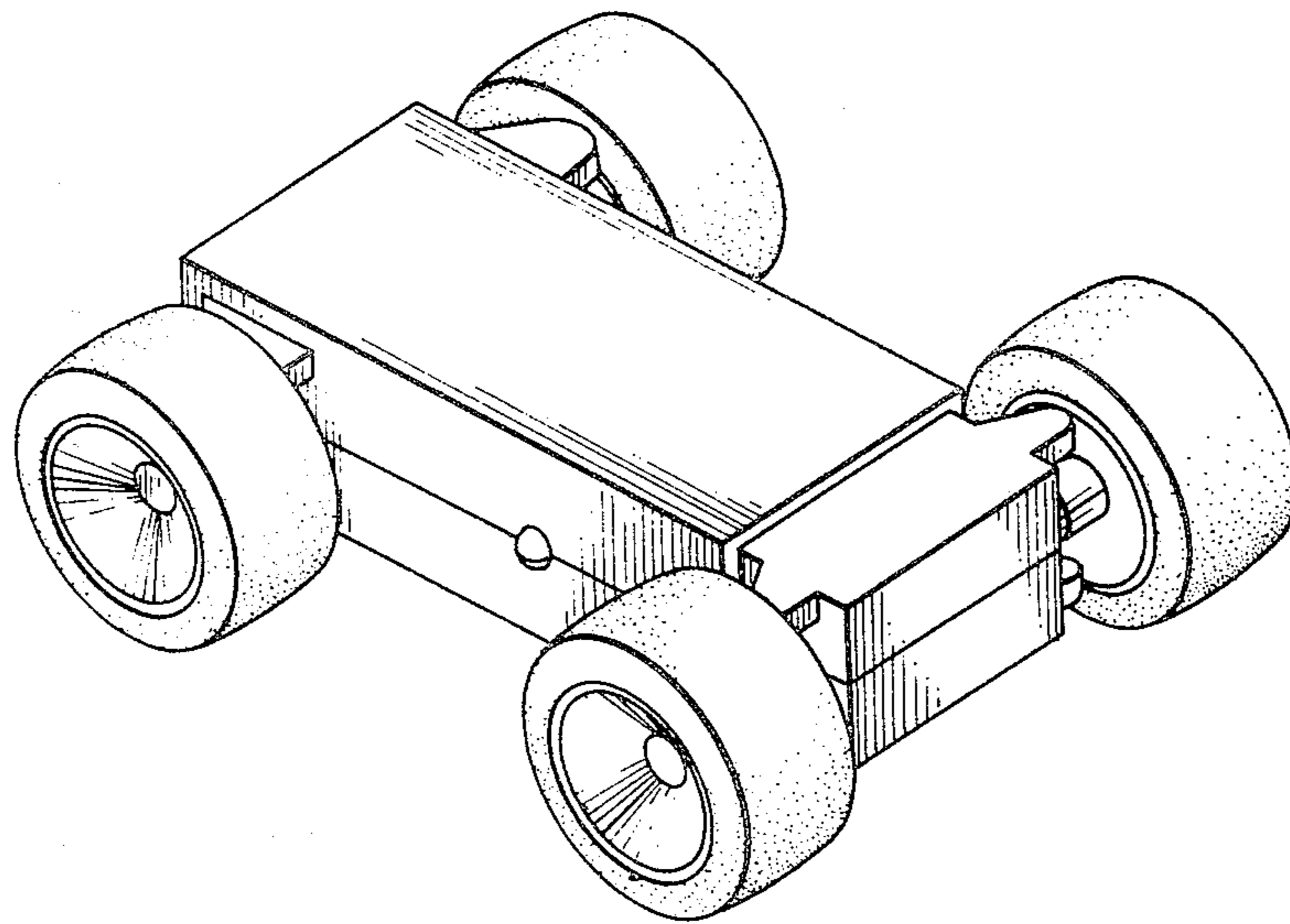

FIG. 1

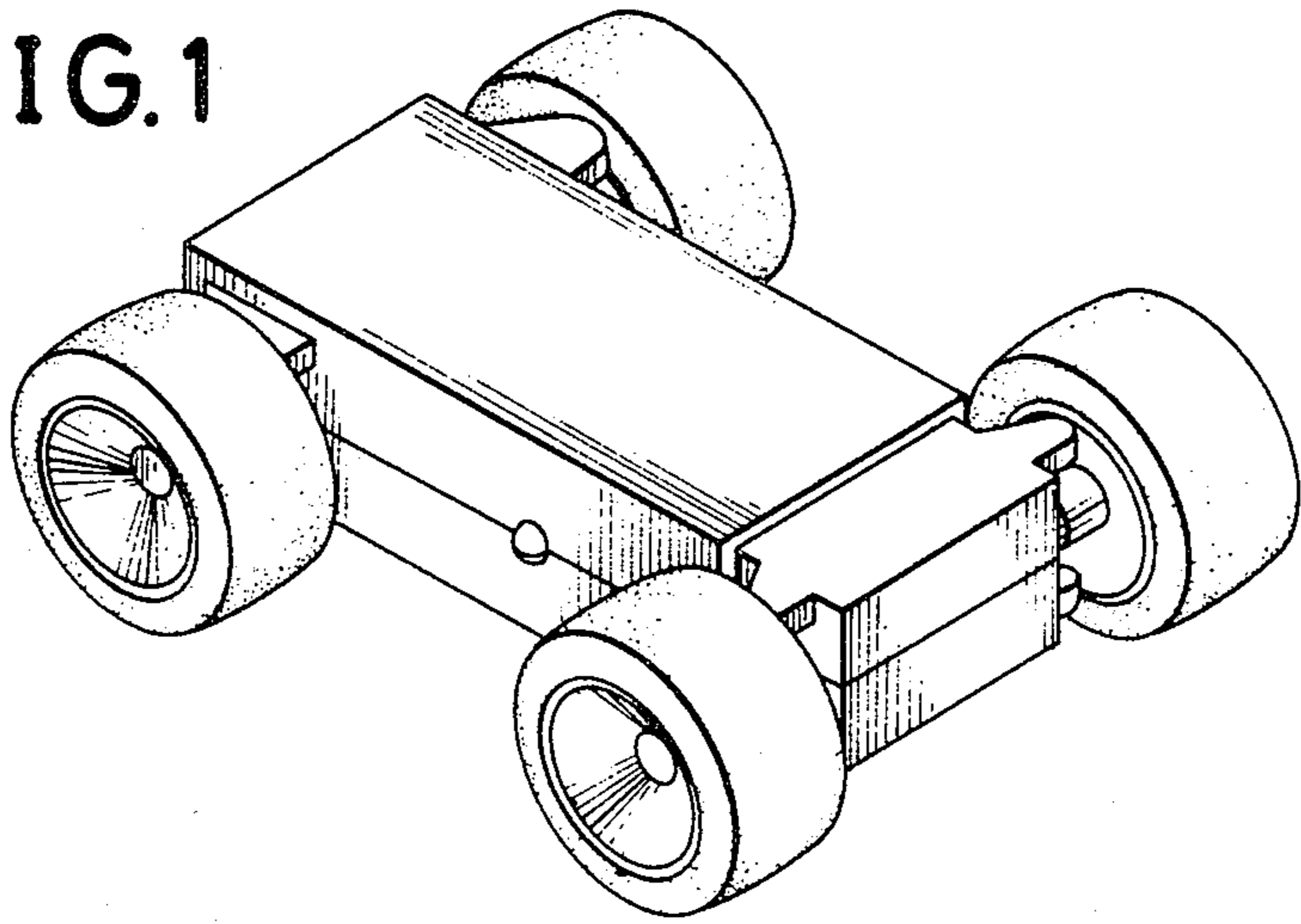

FIG. 2

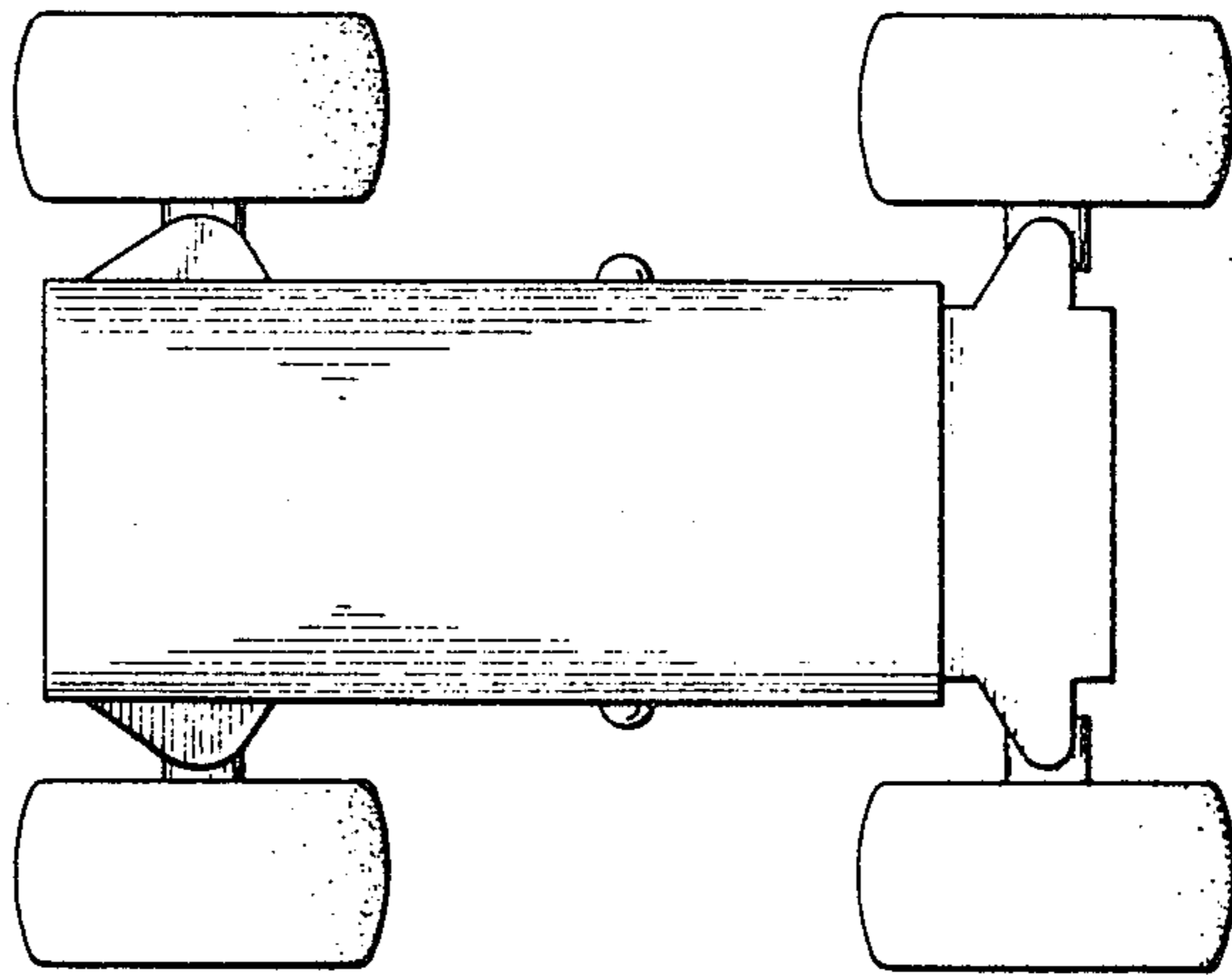

FIG. 3

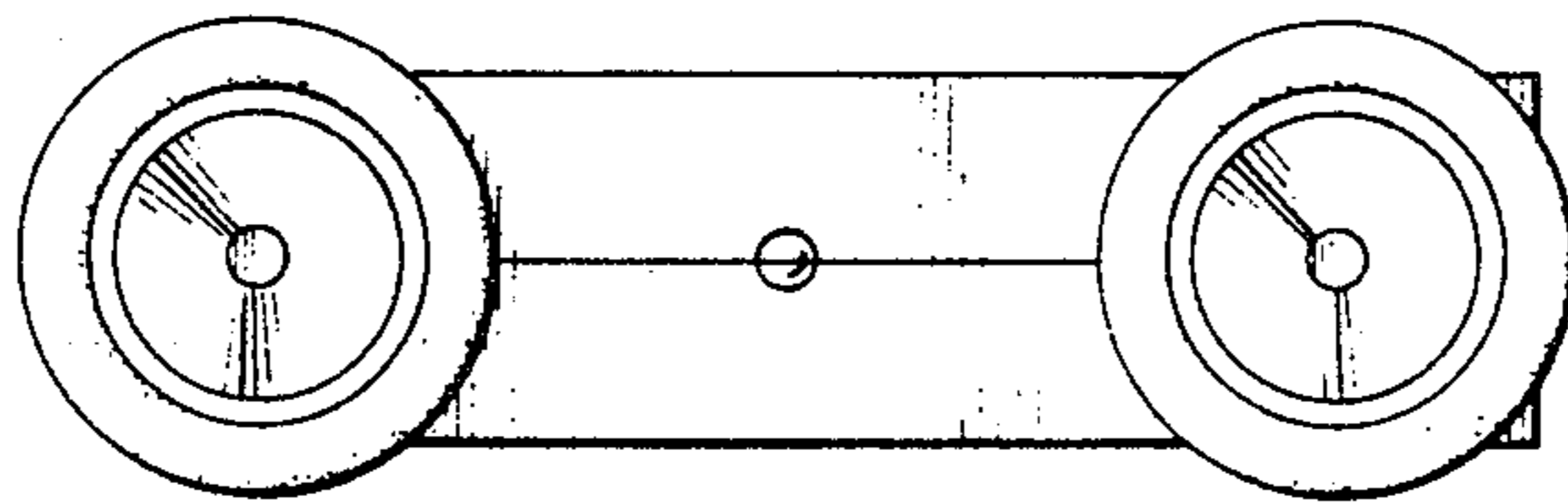

FIG. 4

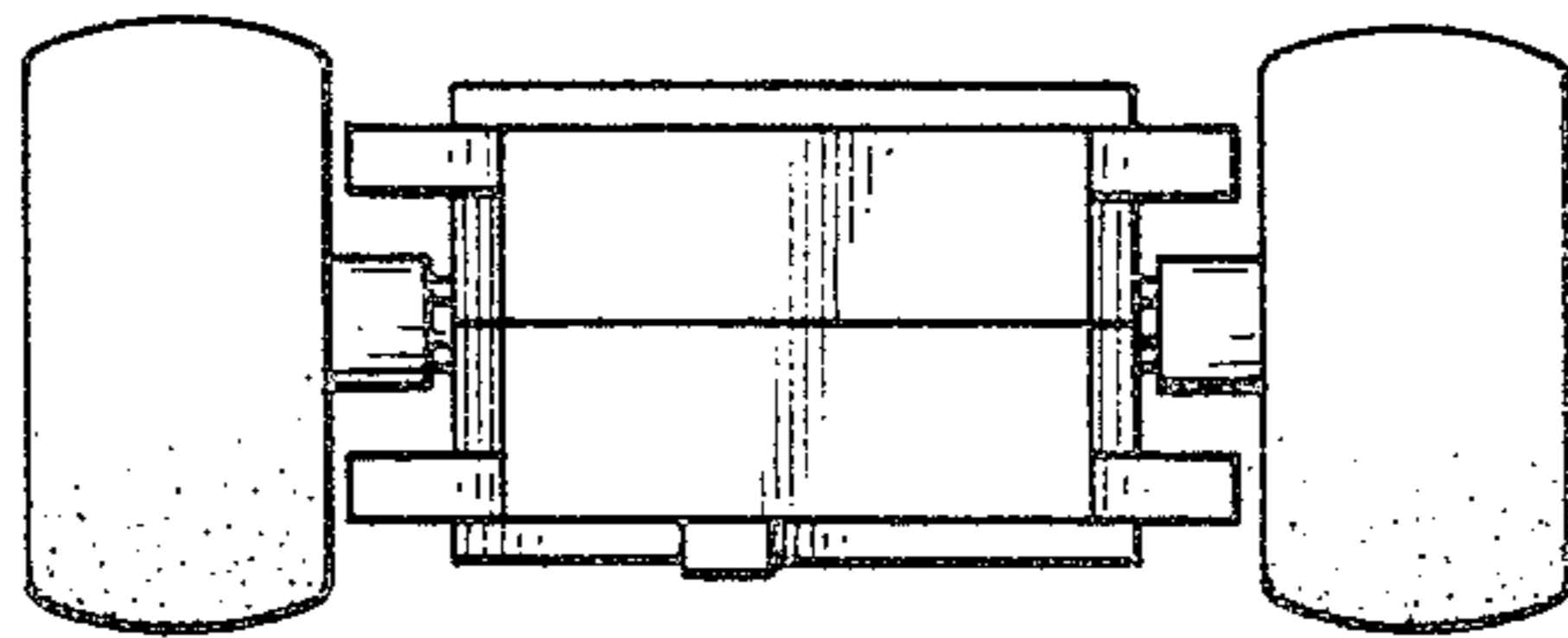

FIG. 5

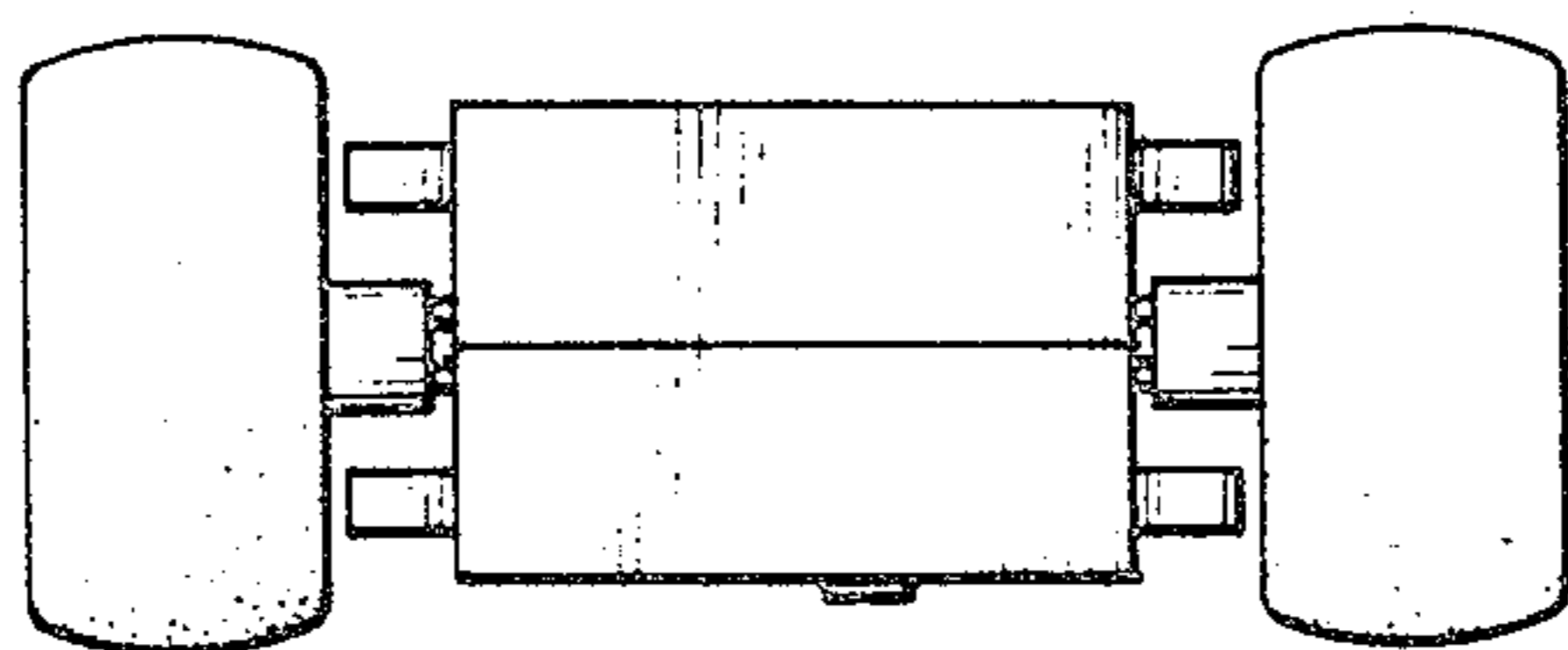

FIG. 6

