

# United States Patent [19]

Takagi

[11] Patent Number: **Des. 284,002**

[45] Date of Patent:\*\*\* **May 27, 1986**

[54] **LOUDSPEAKER**

[75] Inventor: **You Takagi, Tokyo, Japan**

[73] Assignee: **Pioneer Electronic Corporation,  
Tokyo, Japan**

[\*] Notice: The portion of the term of this patent subsequent to Jan. 17, 2000, has been disclaimed.

[\*\*] Term: **14 Years**

[21] Appl. No.: **509,086**

[22] Filed: **Jun. 29, 1983**

[30] **Foreign Application Priority Data**

Jan. 7, 1983 [JP] Japan ..... 58-137

[52] U.S. Cl. .... **D14/30**

[58] Field of Search ..... D14/30, 32-34,  
D14/37, 39

[56] **References Cited**

**U.S. PATENT DOCUMENTS**

D. 254,130 2/1980 Iijima ..... D14/30

D. 254,434 3/1980 Iijima ..... D14/30  
D. 265,556 7/1982 Iijima ..... D14/30  
D. 275,098 8/1984 Flick ..... D14/39 X

*Primary Examiner*—Bernard Ansher  
*Assistant Examiner*—Theodore M. Shooman  
*Attorney, Agent, or Firm*—Sughrue, Mion, Zinn,  
Macpeak and Seas

[57] **CLAIM**

The ornamental design for a loudspeaker, as shown.

**DESCRIPTION**

FIG. 1 is a front elevational view of a loudspeaker showing my new design;  
FIG. 2 is a rear elevational view thereof;  
FIG. 3 is a left side elevational view thereof;  
FIG. 4 is a right side elevational view thereof;  
FIG. 5 is a top plan view thereof;  
FIG. 6 is a bottom plan view thereof; and  
FIG. 7 is a front perspective view thereof.

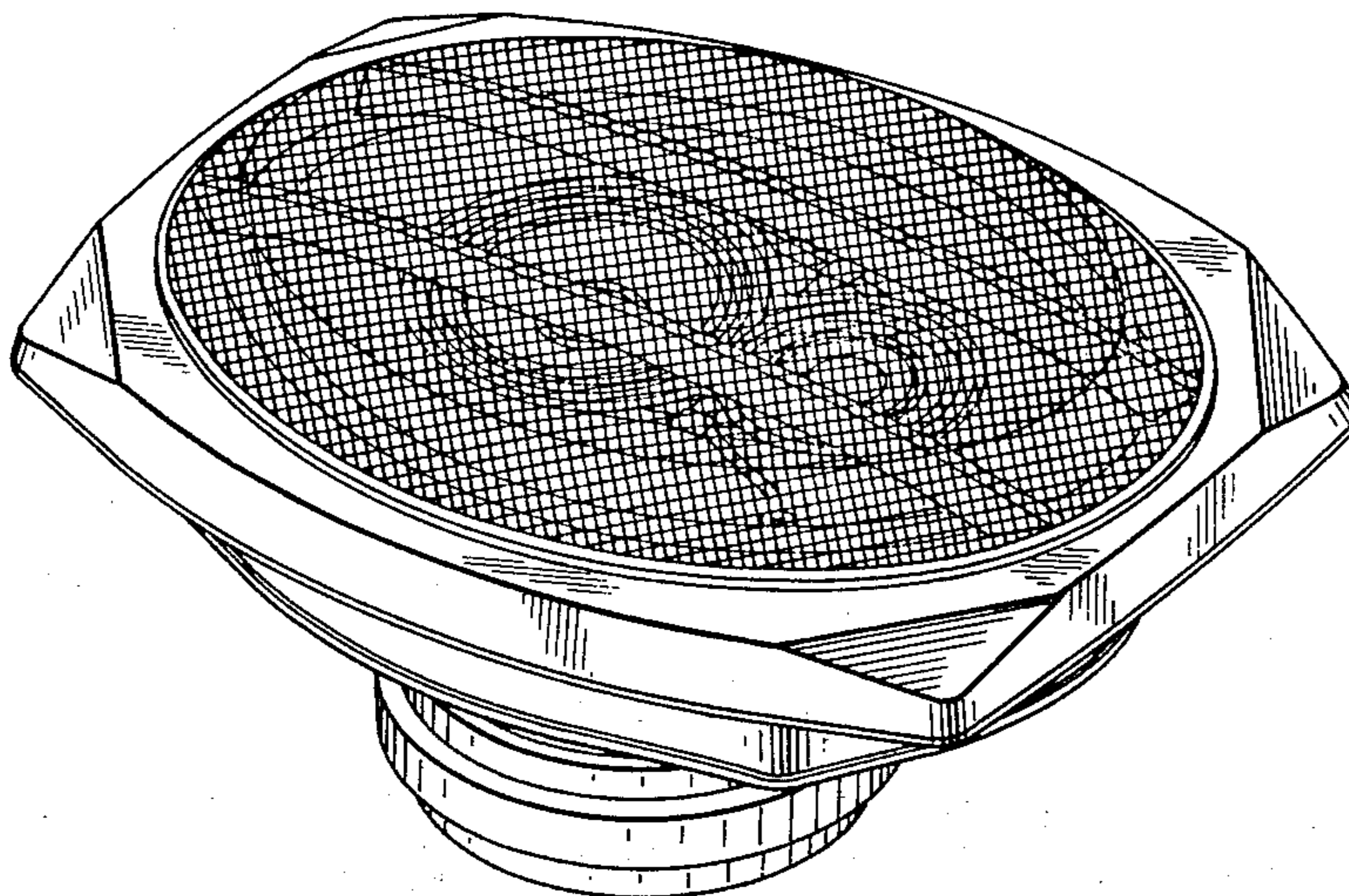

FIG. 1

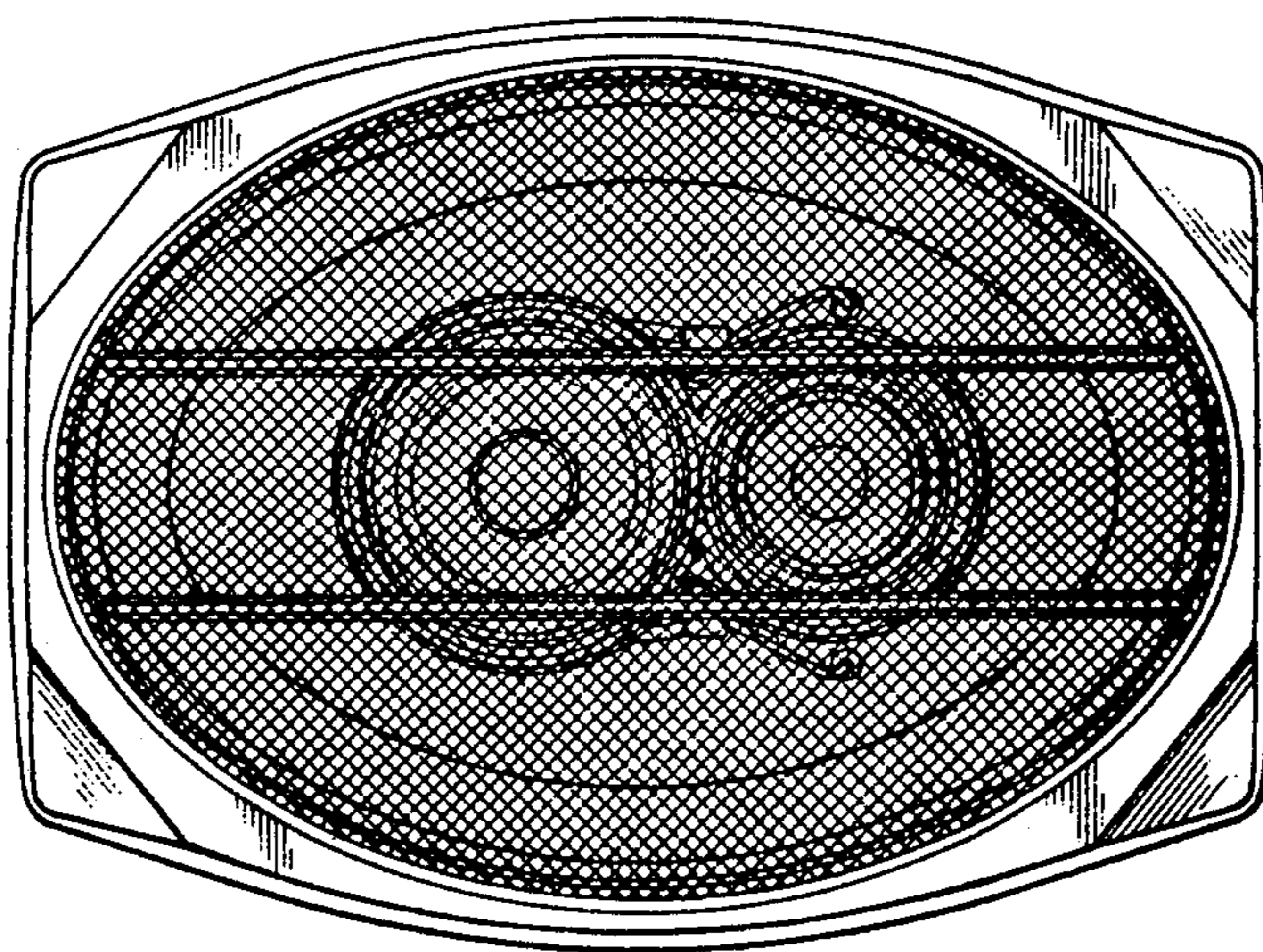

FIG. 2

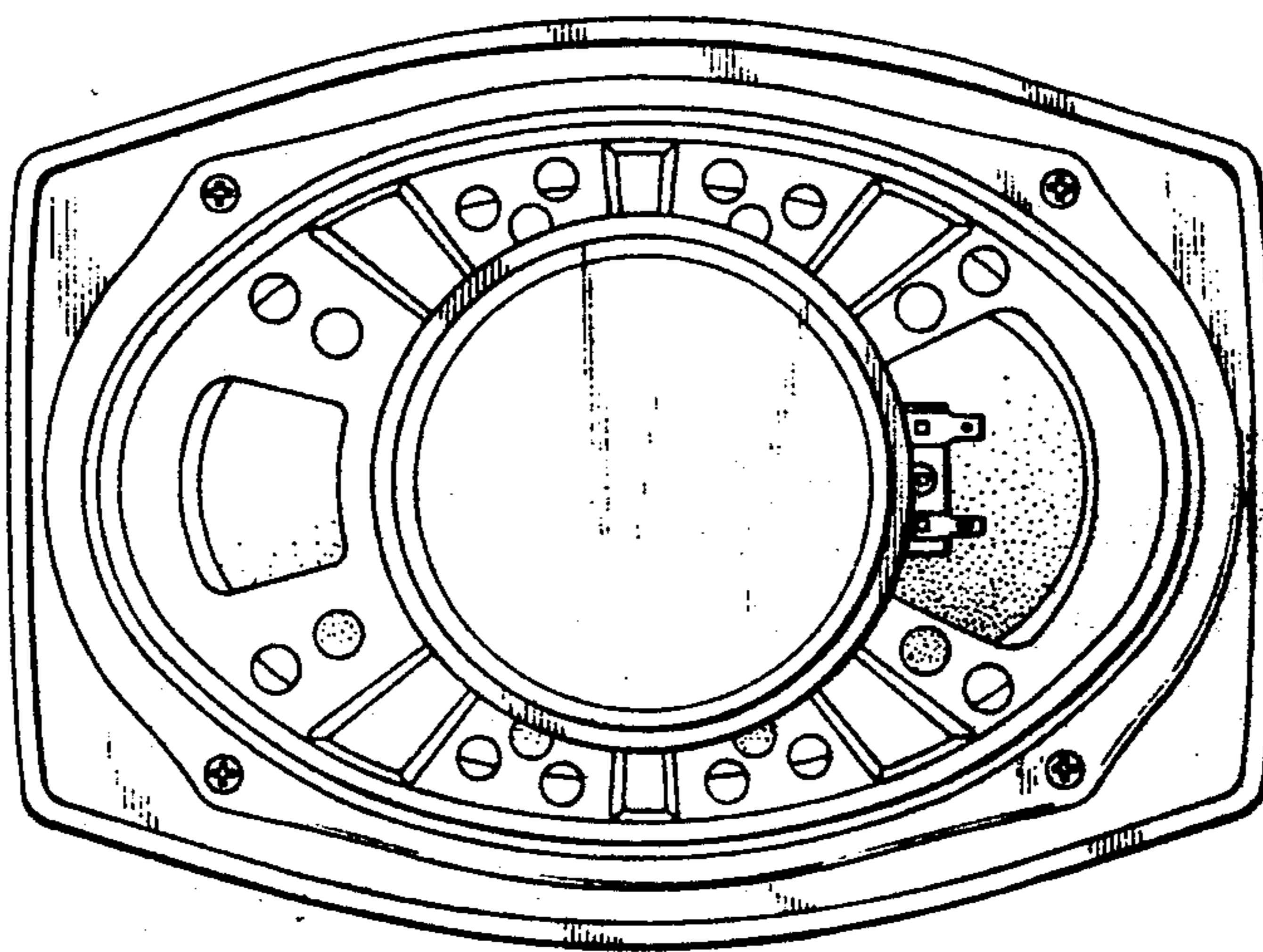

FIG. 3

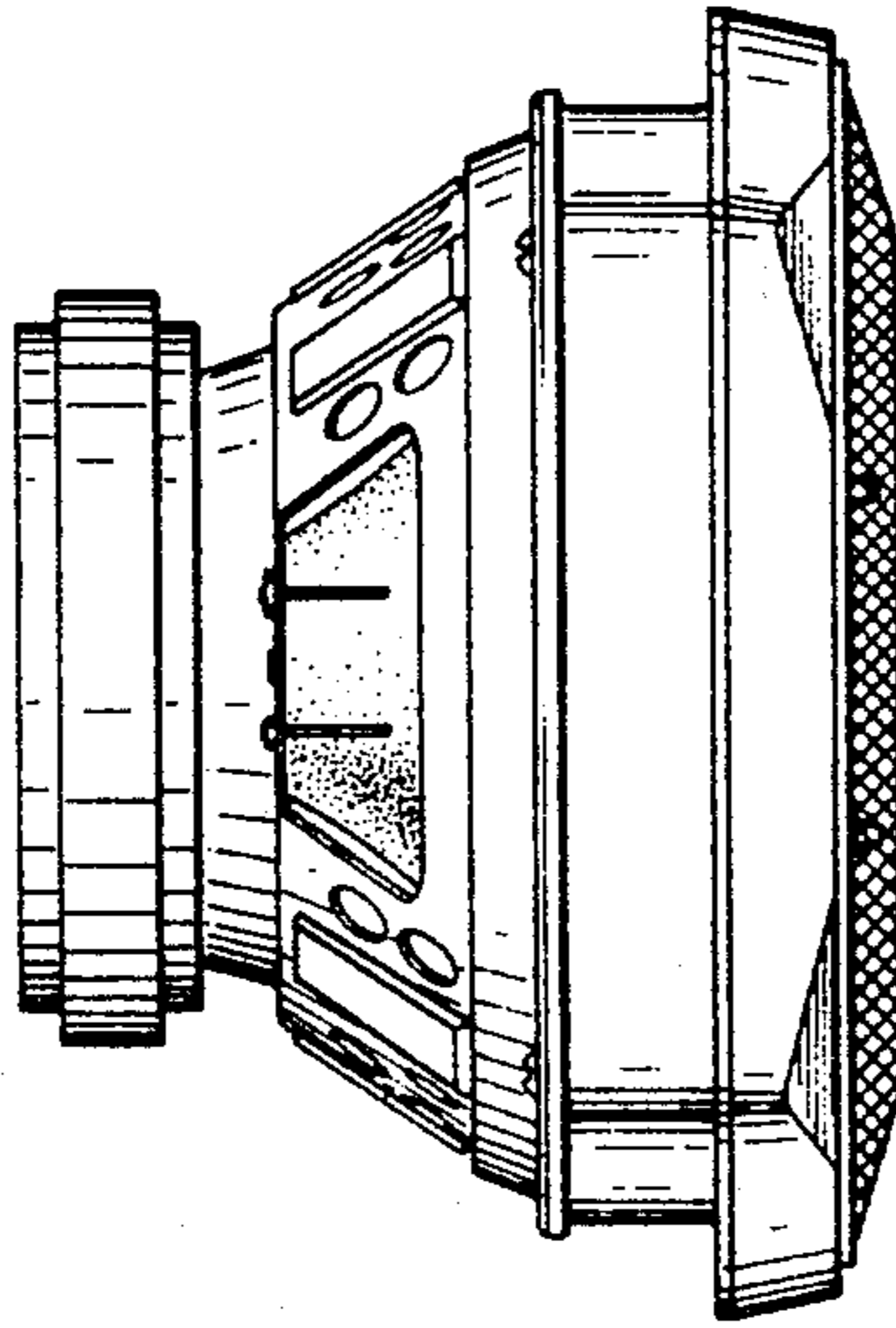

FIG. 4

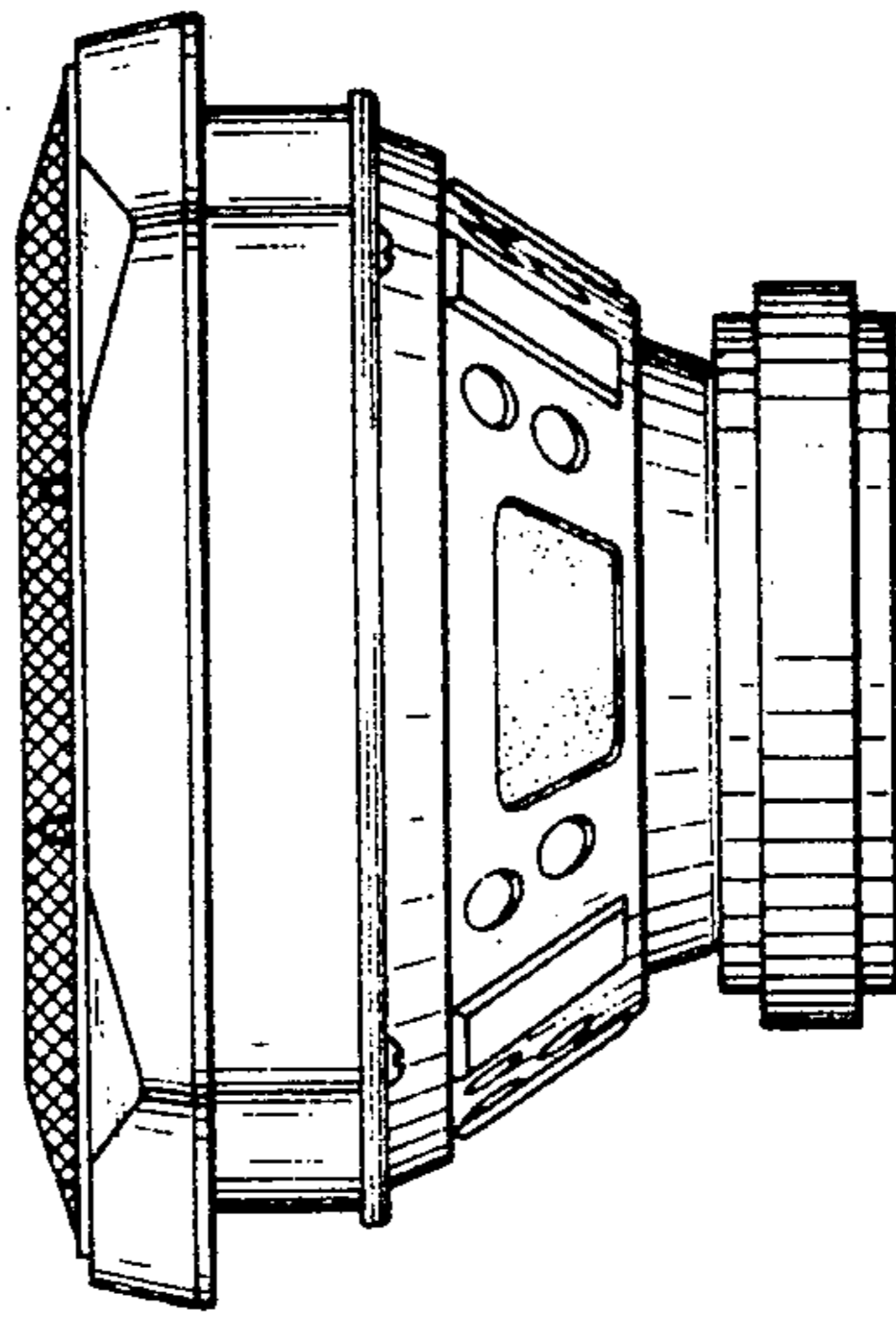

FIG. 5

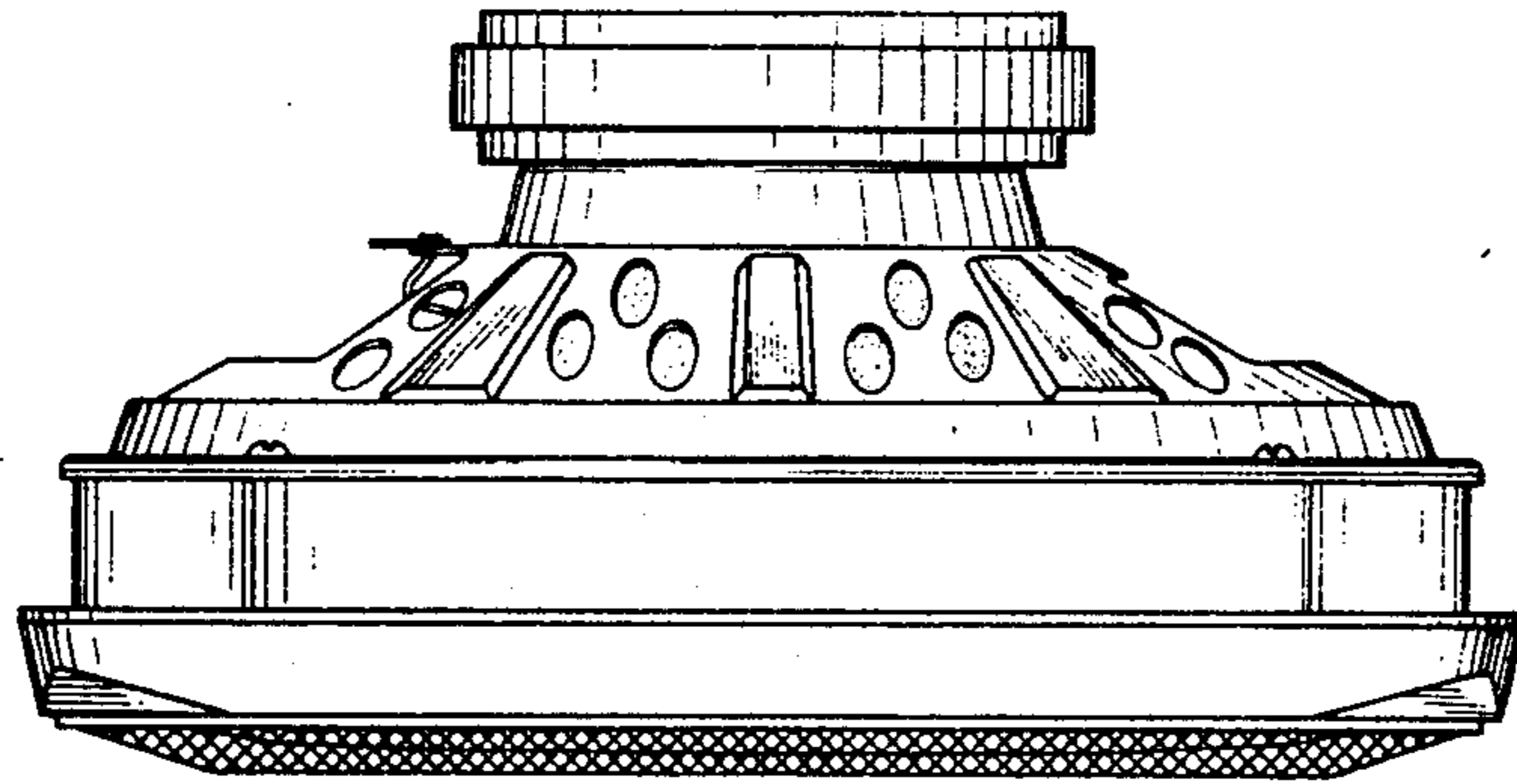

FIG. 6

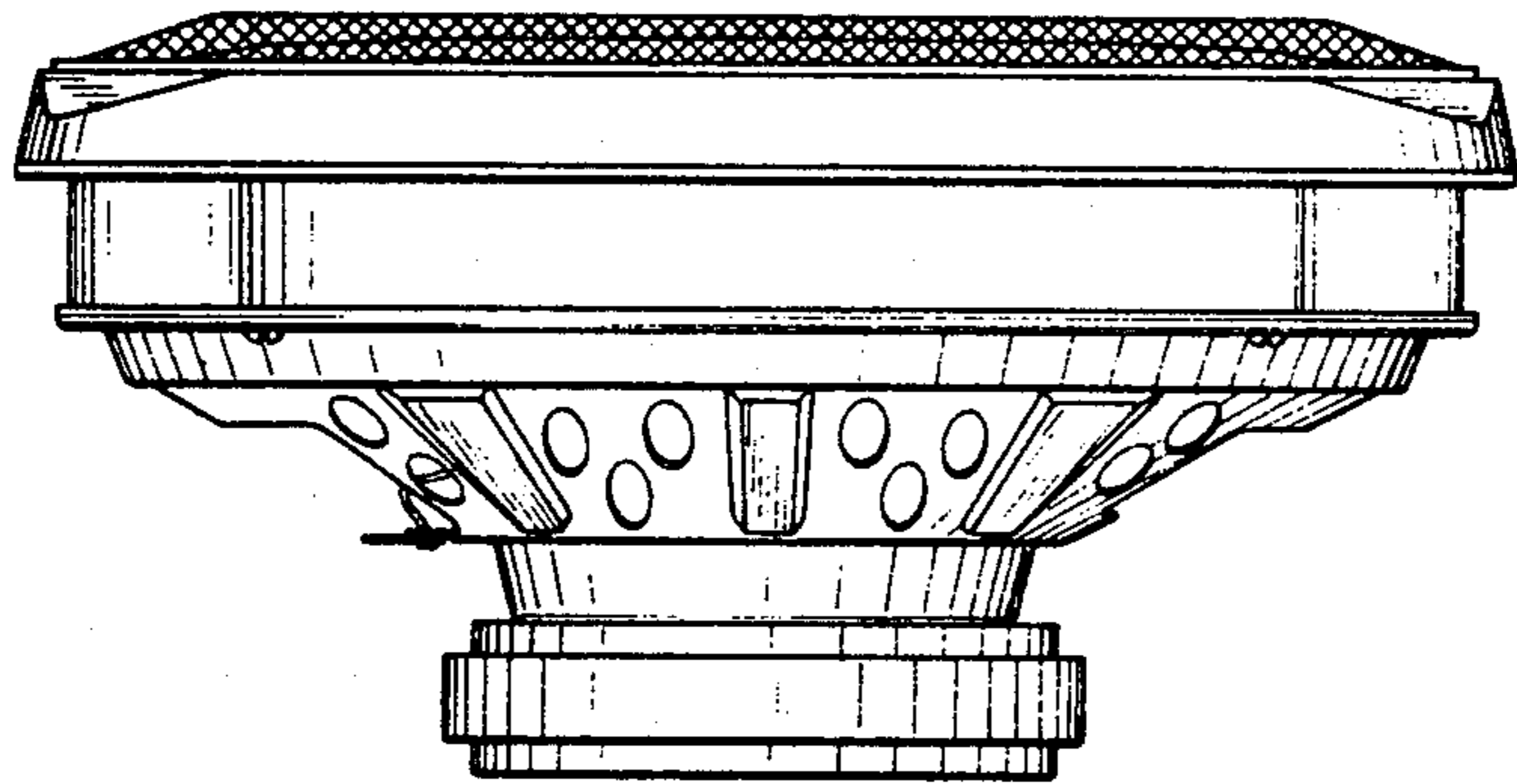

FIG. 7

