

[54] MOTORCYCLE

[75] Inventors: Mitsuyoshi Kohama; Takeshi Oba, both of Tokyo, Japan

[73] Assignee: Honda Giken Kogyo Kabushiki Kaisha, Tokyo, Japan

[**] Term: 14 Years

[21] Appl. No.: 476,826

[22] Filed: Mar. 18, 1983

[30] Foreign Application Priority Data

Sep. 29, 1982 [JP] Japan 57-44500

[52] U.S. Cl. D12/110

[58] Field of Search D12/110; 180/219, 221, 180/229, 231

[56]

References Cited

PUBLICATIONS

Cycle World, 2/82, p. 22, Suzuki PE-175 Motorcycle, top of page.

Cycle World, 2/82, p. 101, Enduro Can-Am Motorcycle, bottom of page.

Primary Examiner—James M. Gandy
Attorney, Agent, or Firm—Lyon & Lyon

[57]

CLAIM

The ornamental design for a motorcycle, as shown and described.

DESCRIPTION

FIG. 1 is a front perspective view of a motorcycle showing our new design;

FIG. 2 is a rear perspective view thereof;

FIG. 3 is a left side elevation view thereof;

FIG. 4 is a right side elevation view thereof;

FIG. 5 is a top perspective view thereof; and

FIG. 6 is a bottom perspective view.

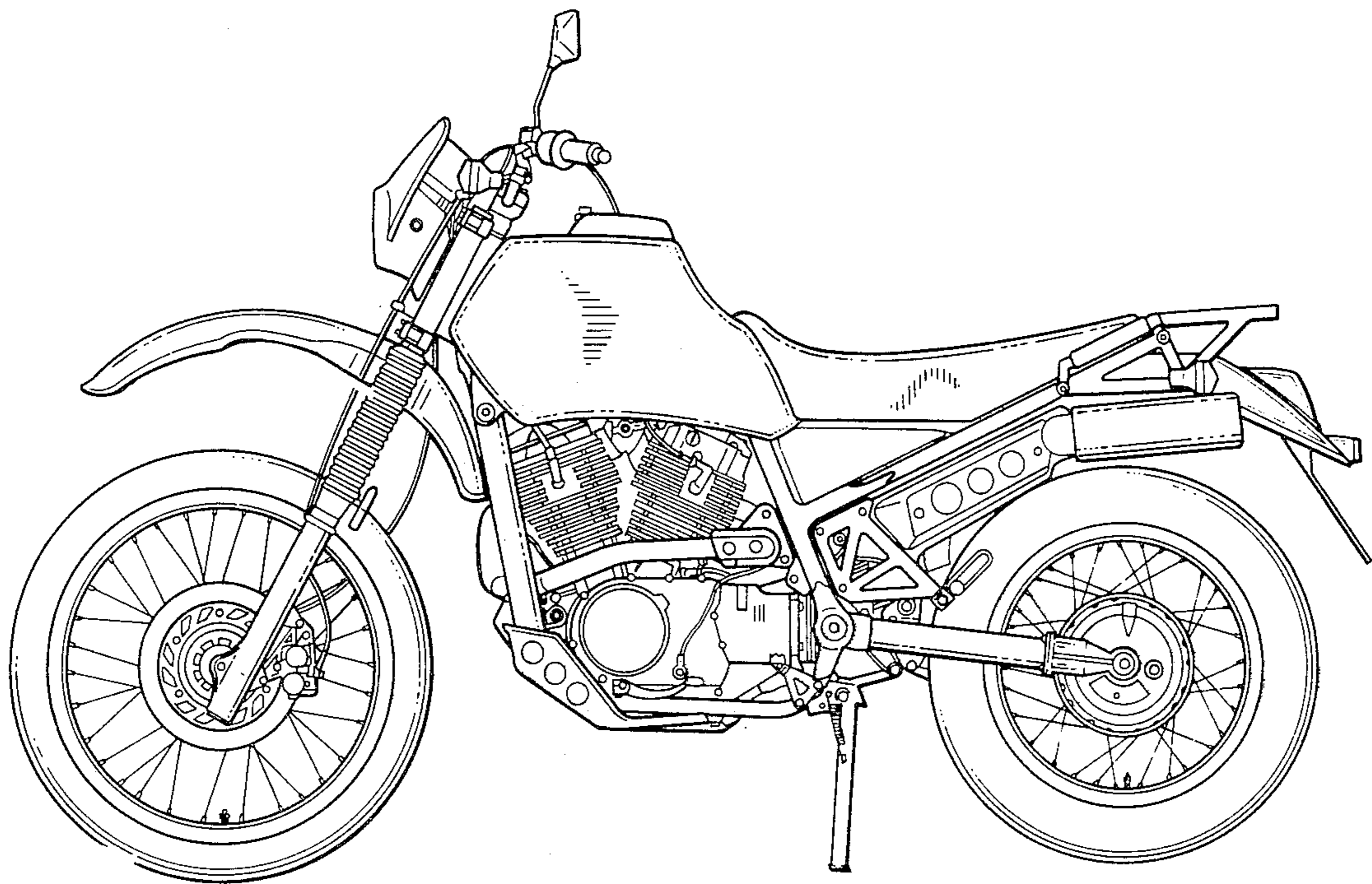

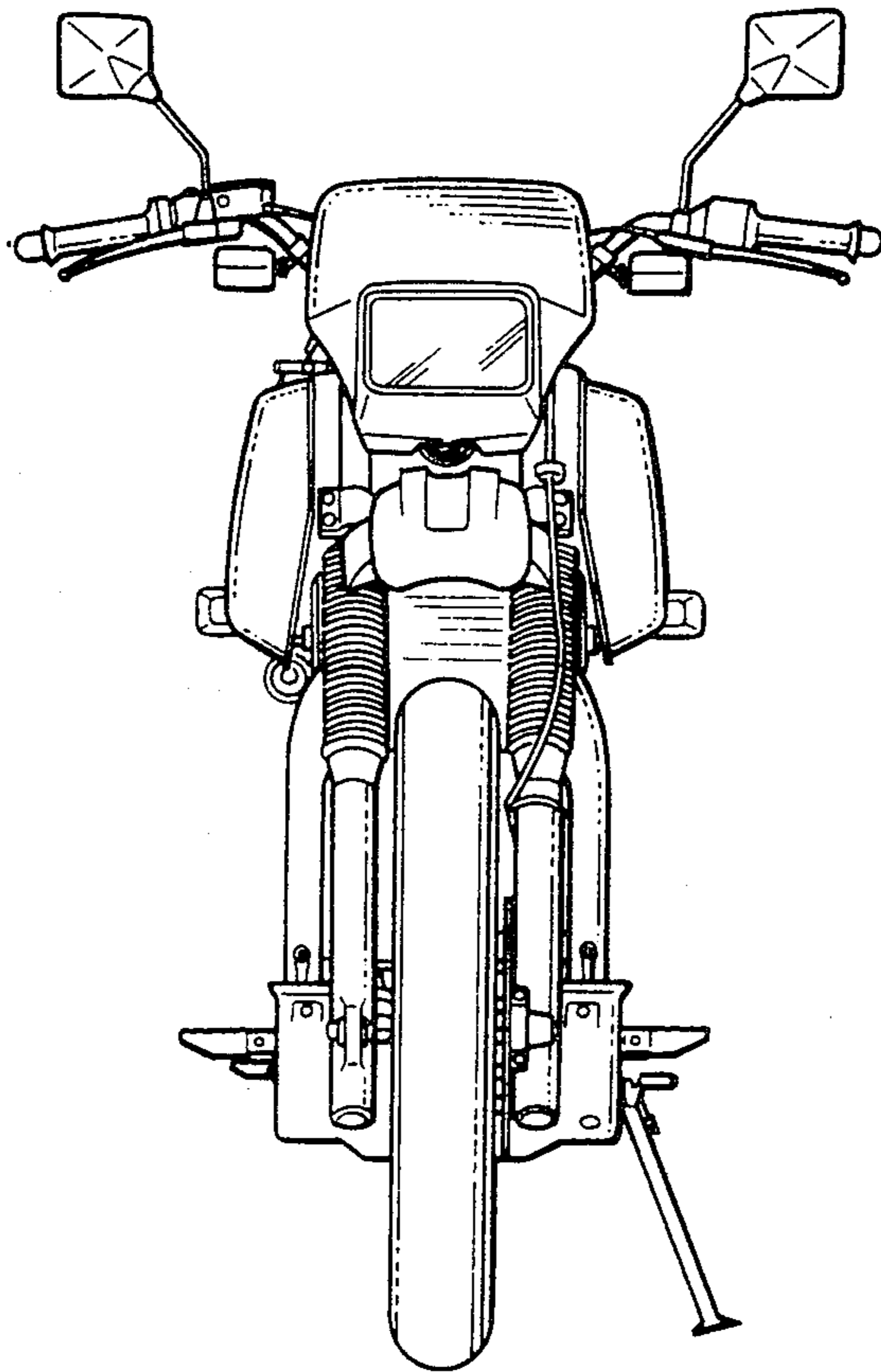

Fig. 1.

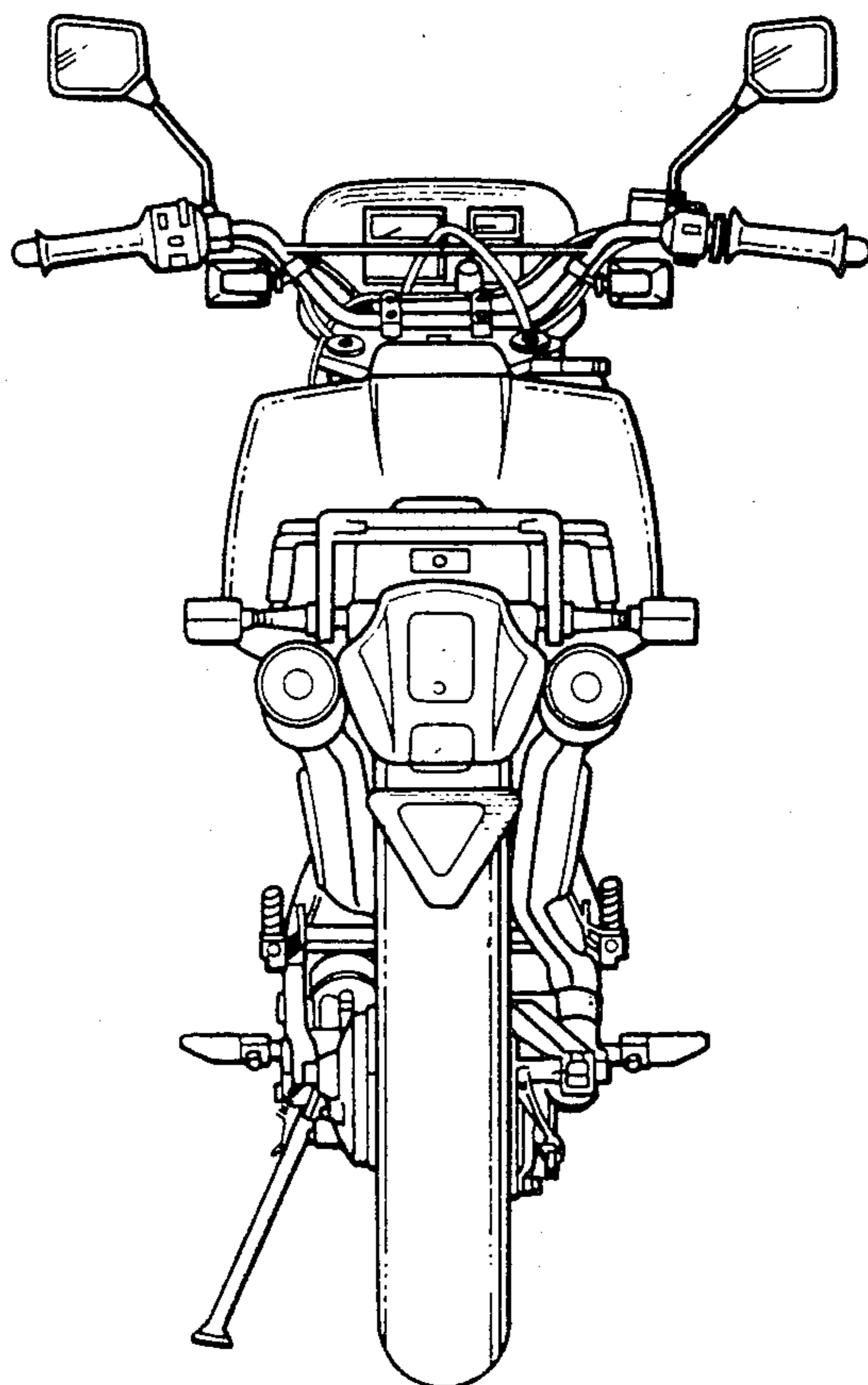

Fig. 2.

Fig. 3.

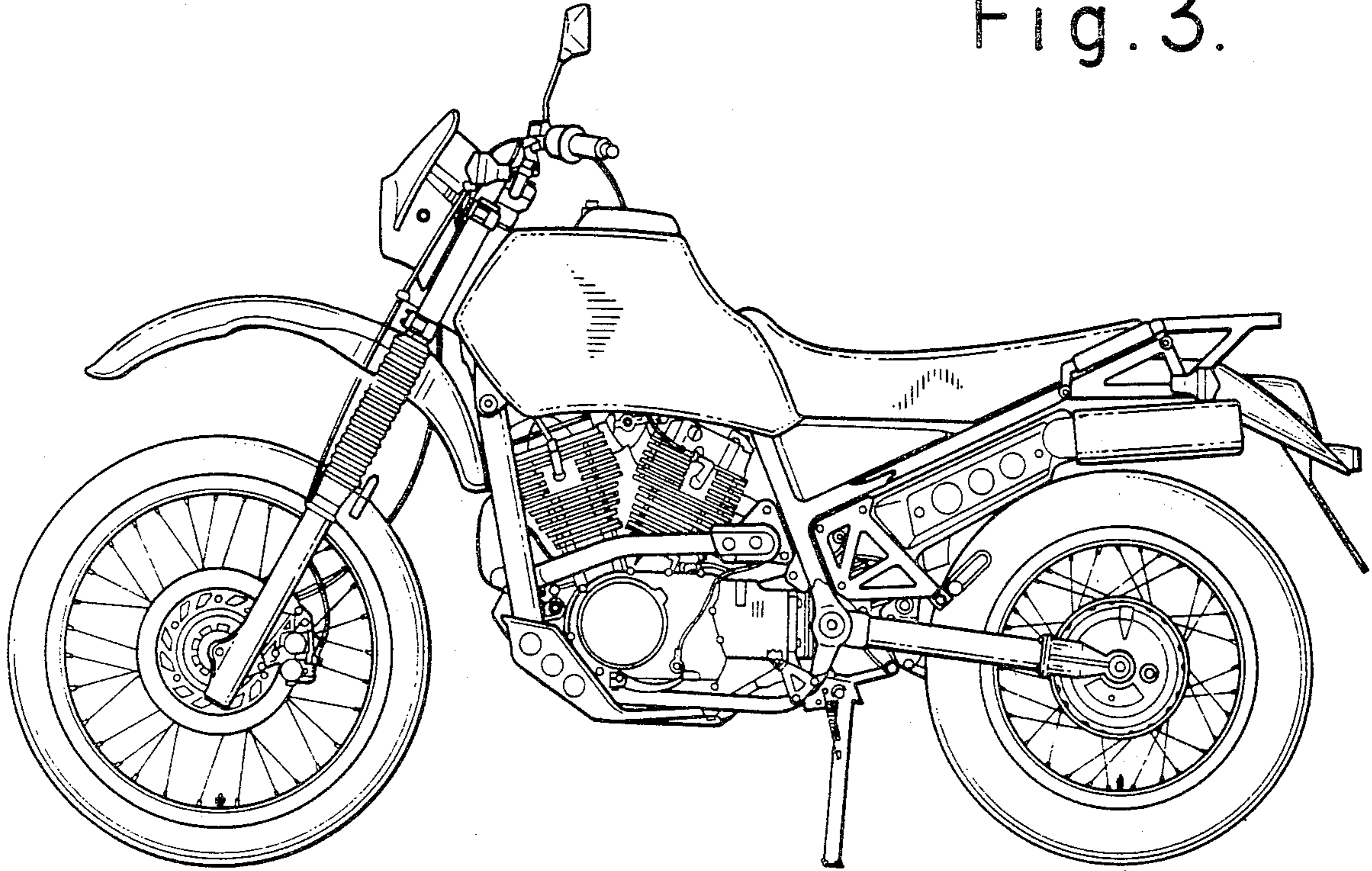
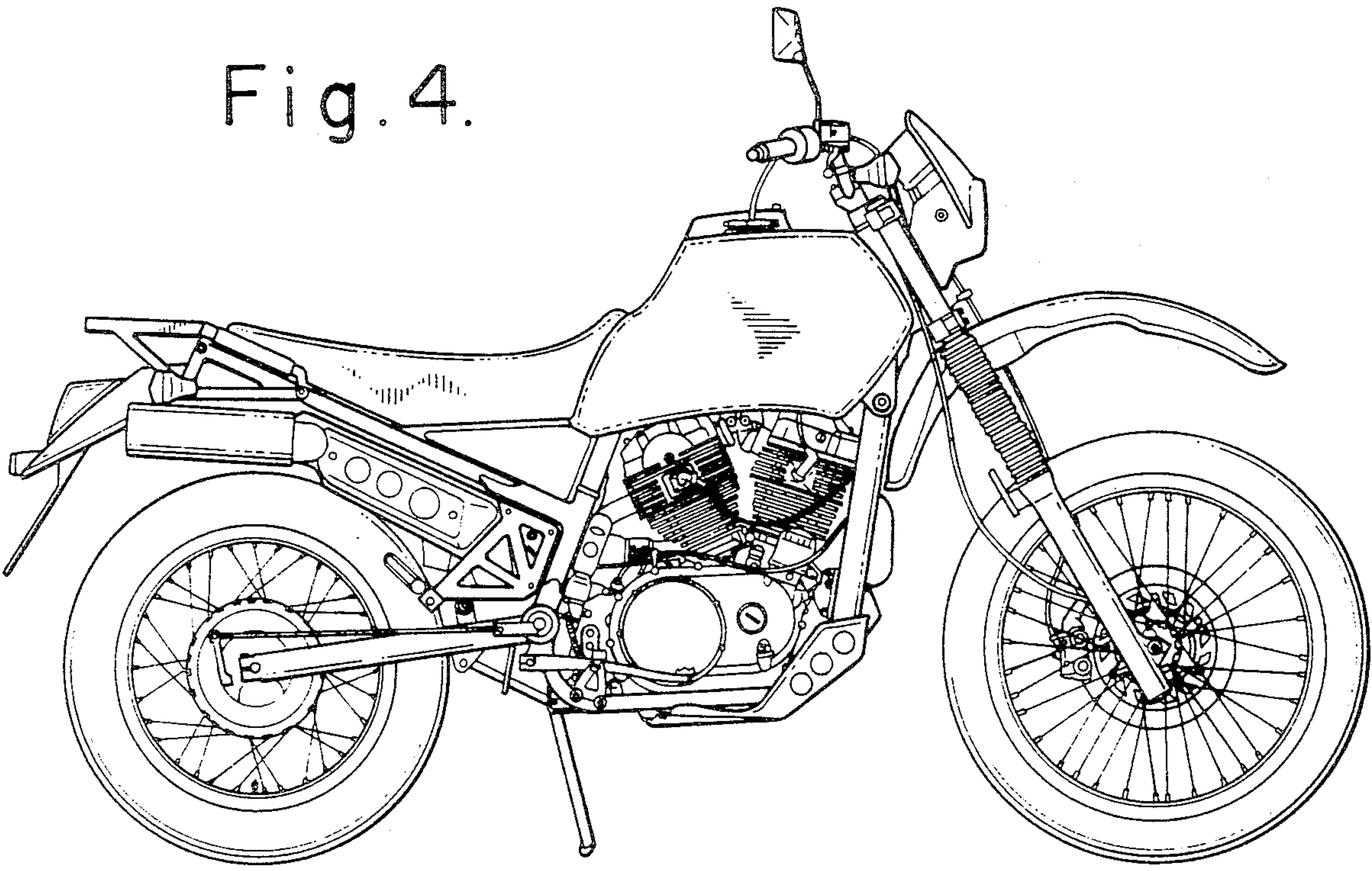

Fig. 4.



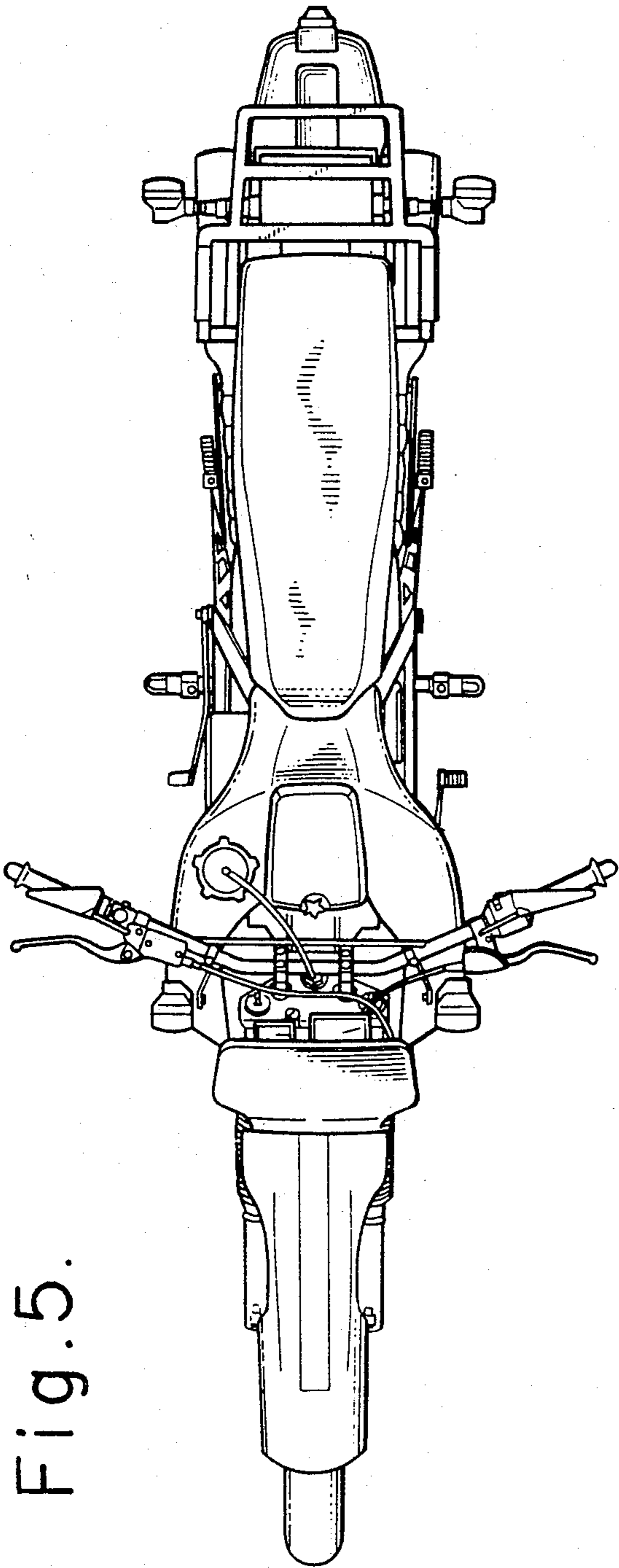

Fig. 5.

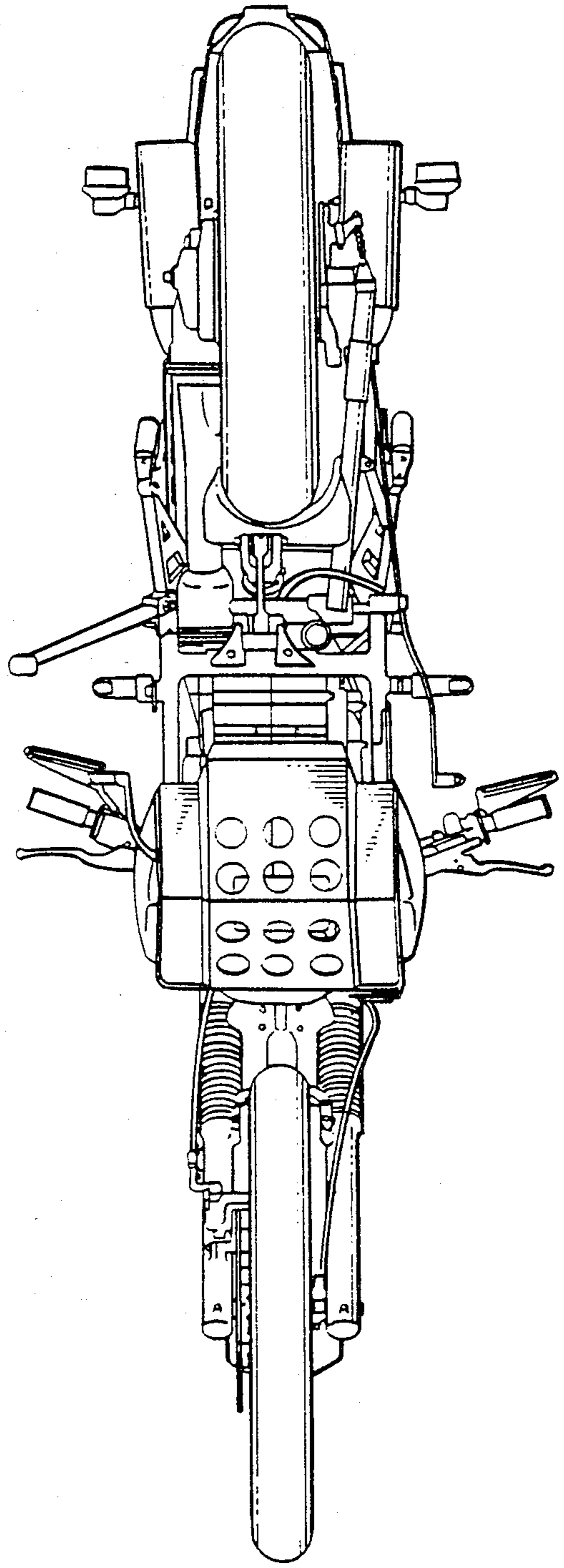

Fig. 6.