

[54] COMBINED ARMORED VEHICLE TURRET AND CONTROL PIT

[75] Inventor: Richard S. LeBlanc, Mt. Clemens, Mich.

[73] Assignee: General Motors Corporation, Detroit, Mich.

[**] Term: 14 Years

[21] Appl. No.: 681,296

[22] Filed: Dec. 13, 1984

Related U.S. Application Data

[63] Continuation of Ser. No. 436,409, Oct. 25, 1982, abandoned.

[52] U.S. Cl. D12/12

[58] Field of Search D12/12; 89/36 H, 36 K, 89/36 L

[56] References Cited

U.S. PATENT DOCUMENTS

- D. 264,322 5/1982 LeBlanc D12/12
- D. 275,270 8/1984 LeBlanc D12/12

Primary Examiner—James M. Gandy
Attorney, Agent, or Firm—Herbert Furman

[57] CLAIM

The ornamental design for a combined armored vehicle turret and control pit, as shown and described.

DESCRIPTION

FIG. 1 is a left-side elevational view of a combined armored vehicle turret and control pit illustrating my new design;

FIG. 2 is a top plan view thereof;

FIG. 3 is a right-side elevational view thereof;

FIG. 4 is a front elevational view thereof; and,

FIG. 5 is a rear elevational view thereof.

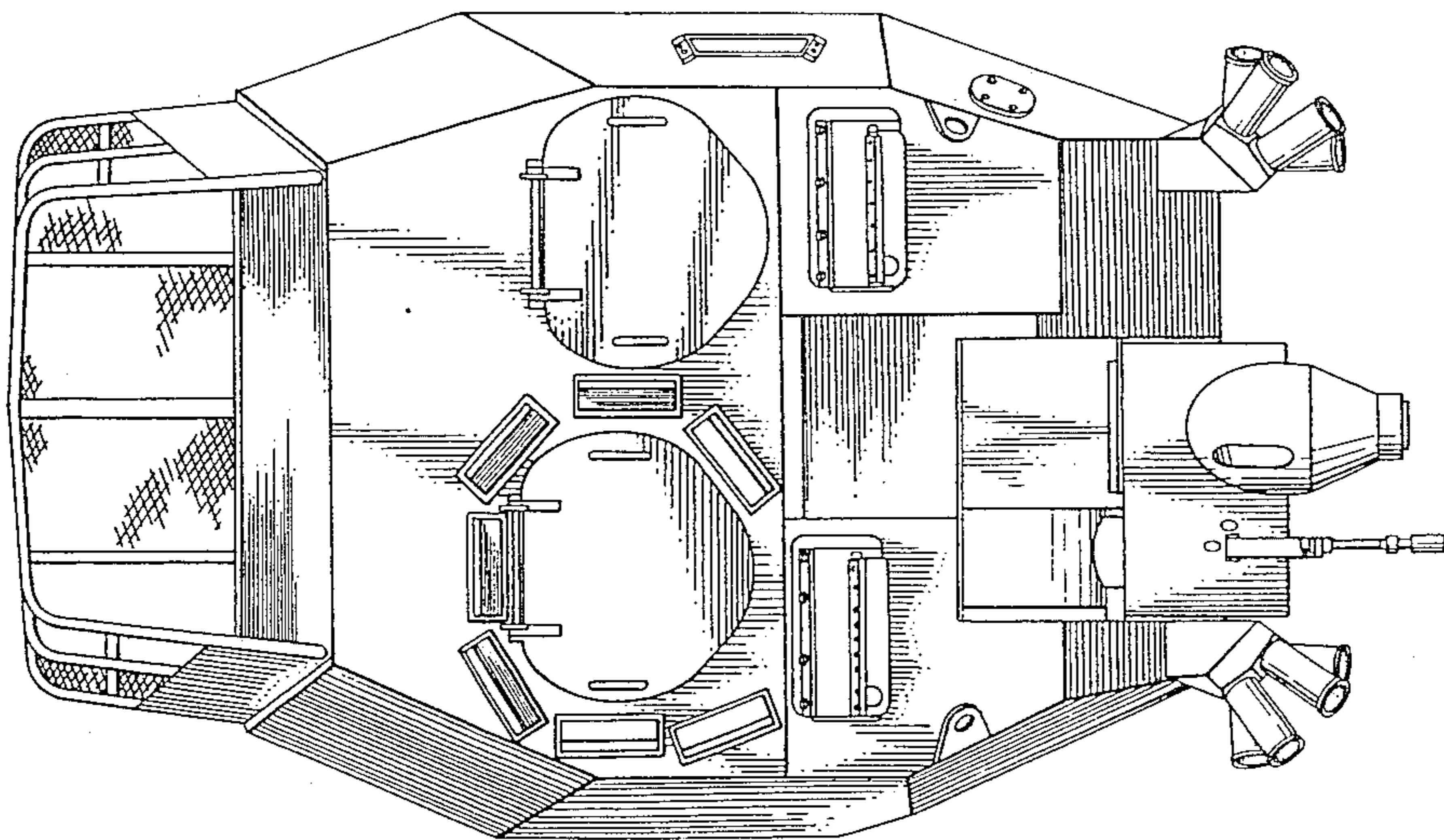
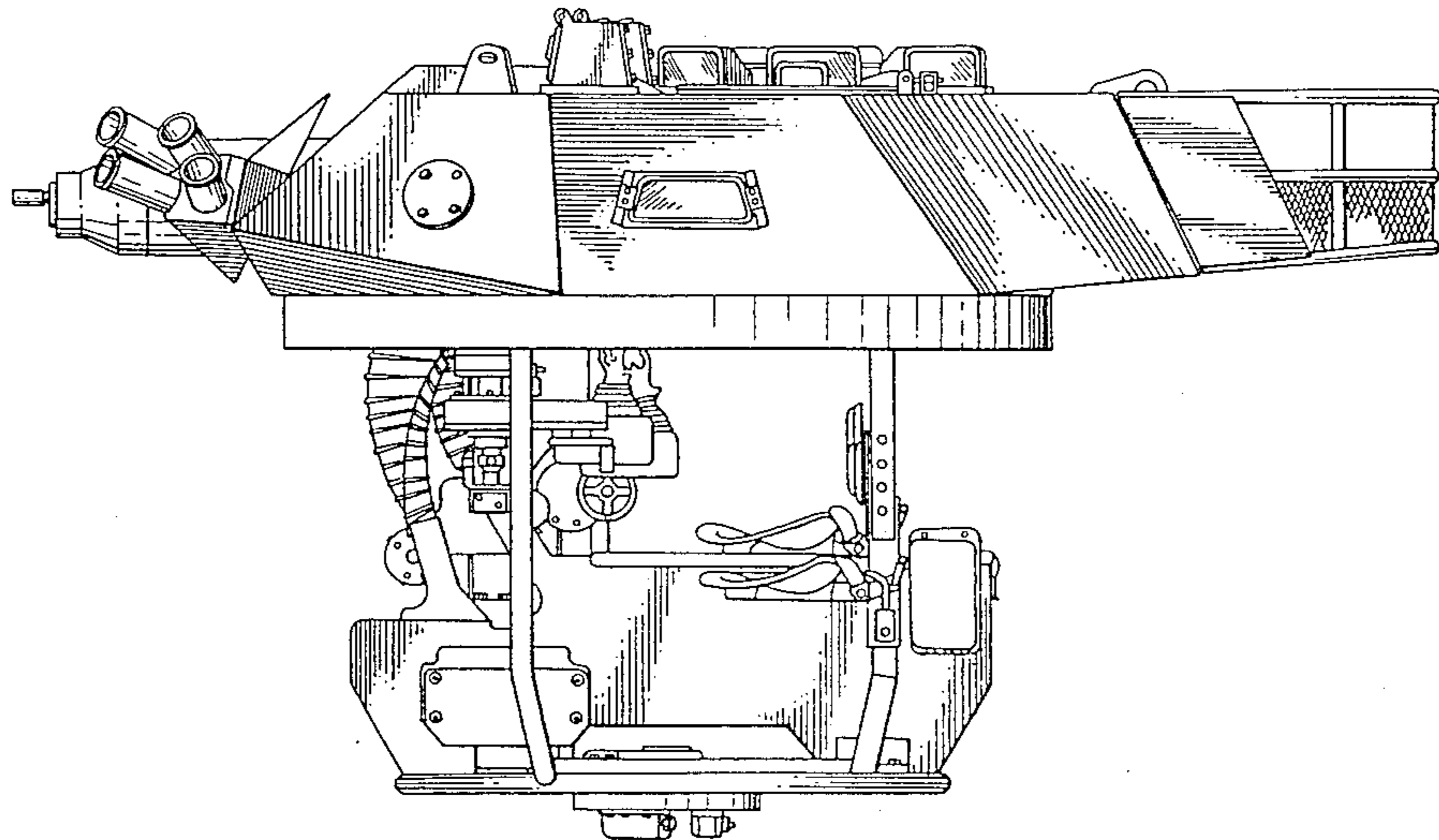

FIG. 1.

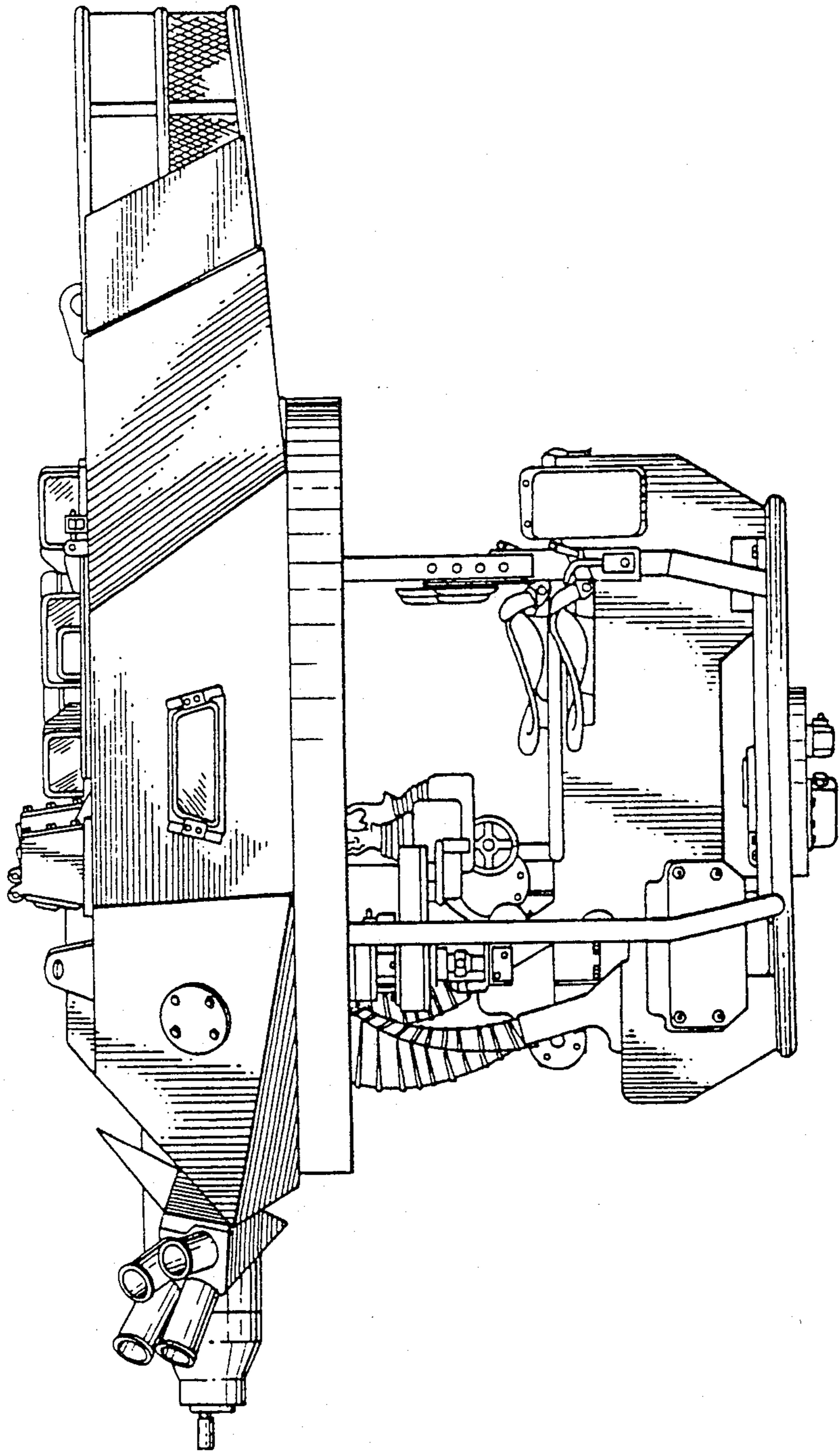

FIG. 2.

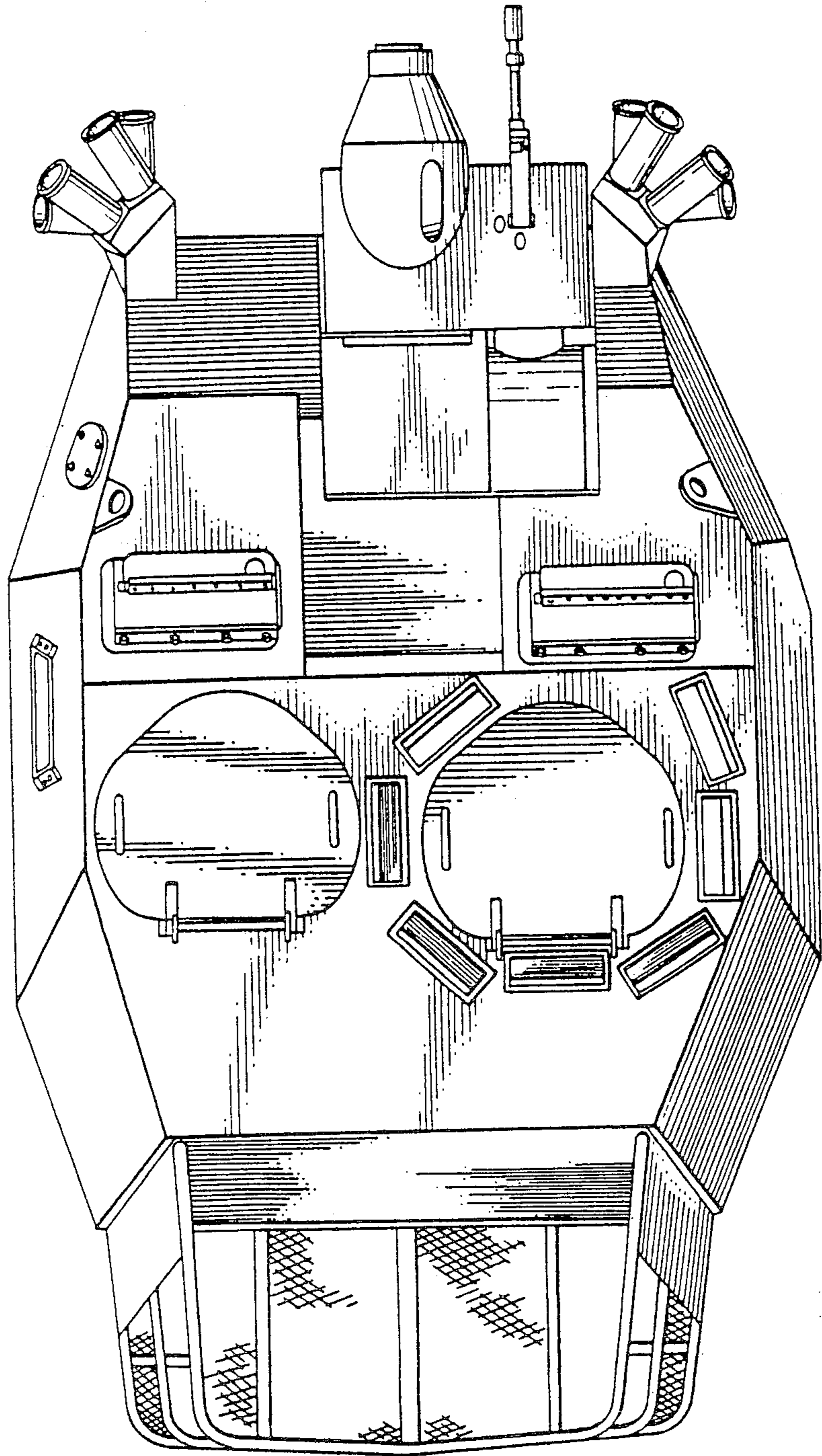

FIG. 3.

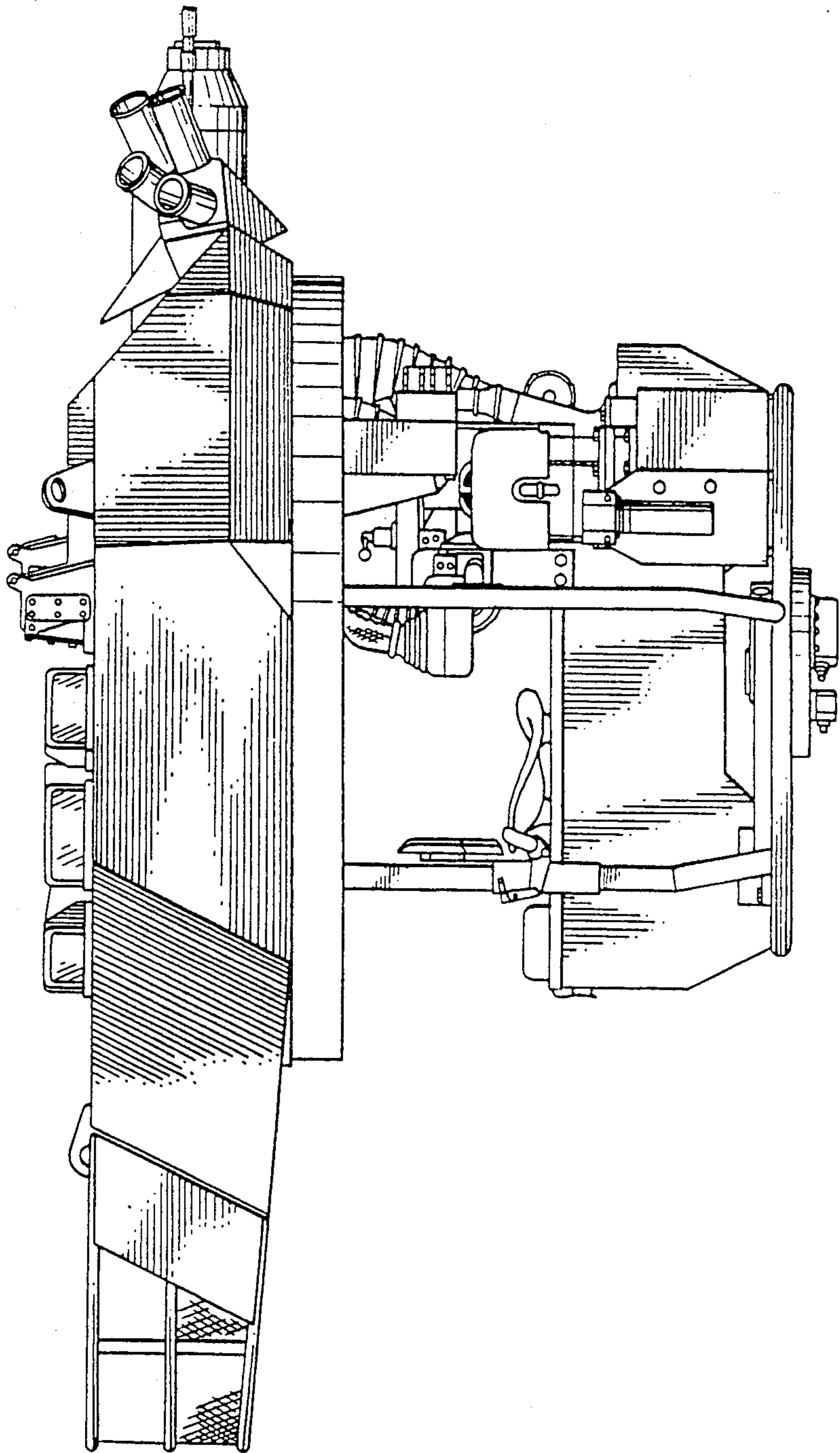

FIG. 5.

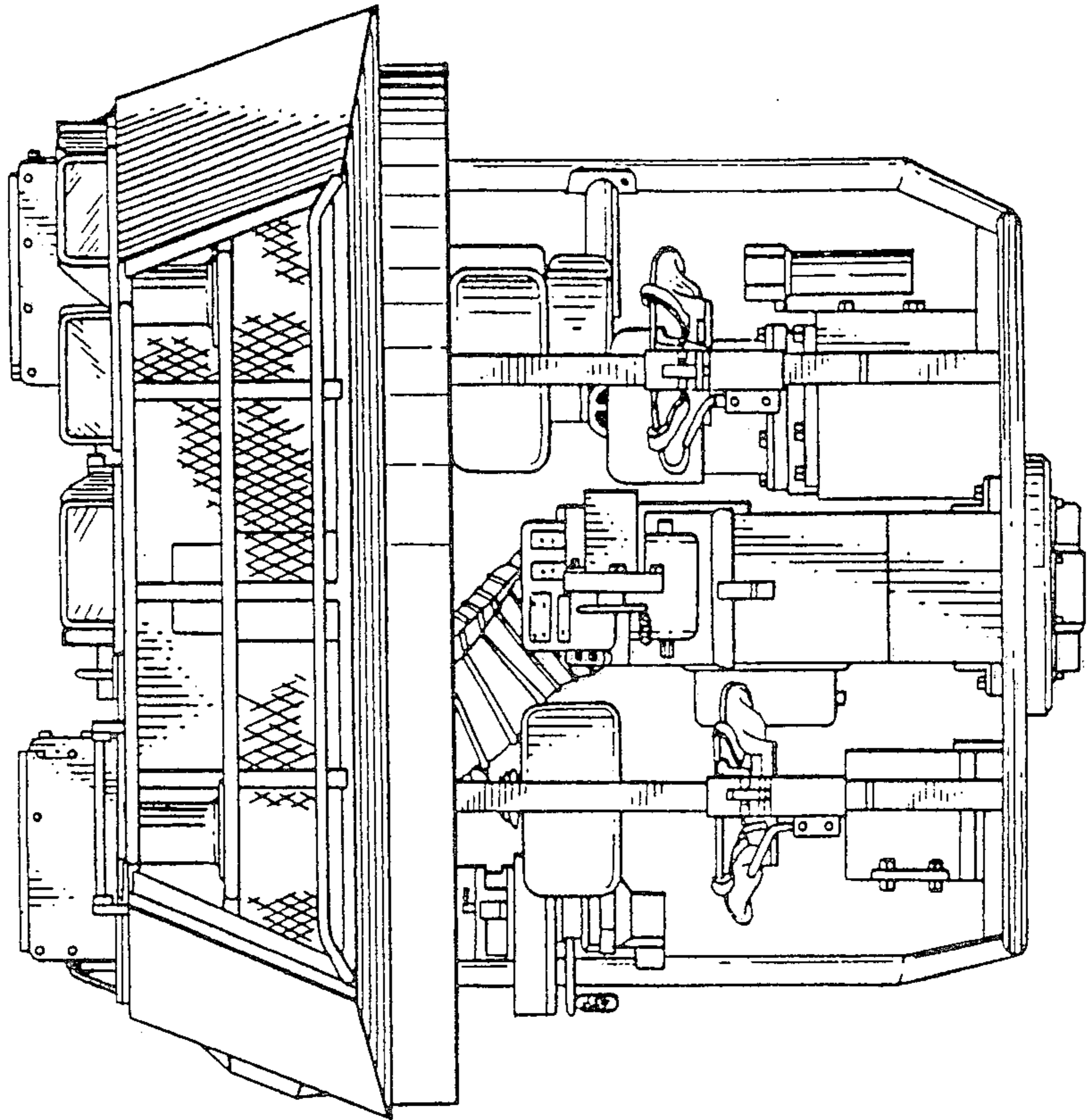

FIG. 4.

