

[54] COMBINED RECONFIGURABLE TOY VEHICULAR AND SIMULATIVE MOTOR UNITS

[75] Inventor: Hiroyuki Obara, Tokyo, Japan

[73] Assignee: Takara Co., Ltd., Tokyo, Japan

[\*\*] Term: 14 Years

[21] Appl. No.: 616,421

[22] Filed: May 30, 1984

[30] Foreign Application Priority Data

Mar. 21, 1984 [JP] Japan ..... 59-10888

[52] U.S. Cl. .... D21/136; D21/128; D21/150; D21/166

[58] Field of Search ..... D21/128-140, D21/166, 177; 446/71, 72, 73, 74, 75, 77, 78; D12/90

[56] References Cited

U.S. PATENT DOCUMENTS

D. 246,126	10/1977	Ogawa	.....	D21/150
D. 274,165	6/1984	Duennes	.....	D21/134
D. 275,122	8/1984	Murakami	.....	D21/150
D. 279,017	5/1985	Boudreaux	.....	D21/128
D. 279,307	6/1985	Murakami	.....	D21/136
D. 279,916	7/1985	Obara	.....	D21/136
D. 281,087	10/1985	Ohno	.....	D21/136

Primary Examiner—Charles A. Rademaker  
Attorney, Agent, or Firm—Price, Gess & Ubell

[57] CLAIM

The ornamental design for a combined reconfigurable toy vehicular and simulative motor units, substantially as shown and described.

DESCRIPTION

FIG. 1 is a front elevational view of a reconfigurable

toy vehicular and simulative motor units showing my new design in a vehicular condition;  
 FIG. 2 is a rear elevational view thereof;  
 FIG. 3 is a top plan view thereof;  
 FIG. 4 is a top plan view thereof;  
 FIG. 5 is a bottom plan view thereof;  
 FIG. 6 is a front elevational view thereof reconfigured with the motor units;  
 FIG. 7 is a rear elevational view thereof;  
 FIG. 8 is a side elevational view thereof;  
 FIG. 9 is a top plan view thereof;  
 FIG. 10 is a bottom plan view thereof;  
 FIG. 11 is a front elevational view of the design shown in FIGS. 1 through 5 reconfigured in a humanoid condition;  
 FIG. 12 is a rear elevational view thereof;  
 FIG. 13 is a right side elevational view thereof;  
 FIG. 14 is a left side elevational view thereof;  
 FIG. 15 is a top plan view thereof;  
 FIG. 16 is a bottom plan view thereof;  
 FIG. 17 is a side perspective view thereof showing the design in a transitory condition;  
 FIG. 18 is another side perspective view thereof showing the design in a transitory condition;  
 FIG. 19 is another side perspective view thereof showing the design in a transitory condition;  
 FIG. 20 is another side perspective view thereof showing the design in a transitory condition;  
 FIG. 21 is a perspective view of the design shown in FIGS. 1 through 5 in a vehicular condition;  
 FIG. 22 is another perspective view thereof reconfigured with the motor units;  
 FIG. 23 is a front perspective view of the design shown in FIGS. 1 through 5 in a humanoid configuration; and,  
 FIG. 24 is another front perspective view thereof with the motor units.

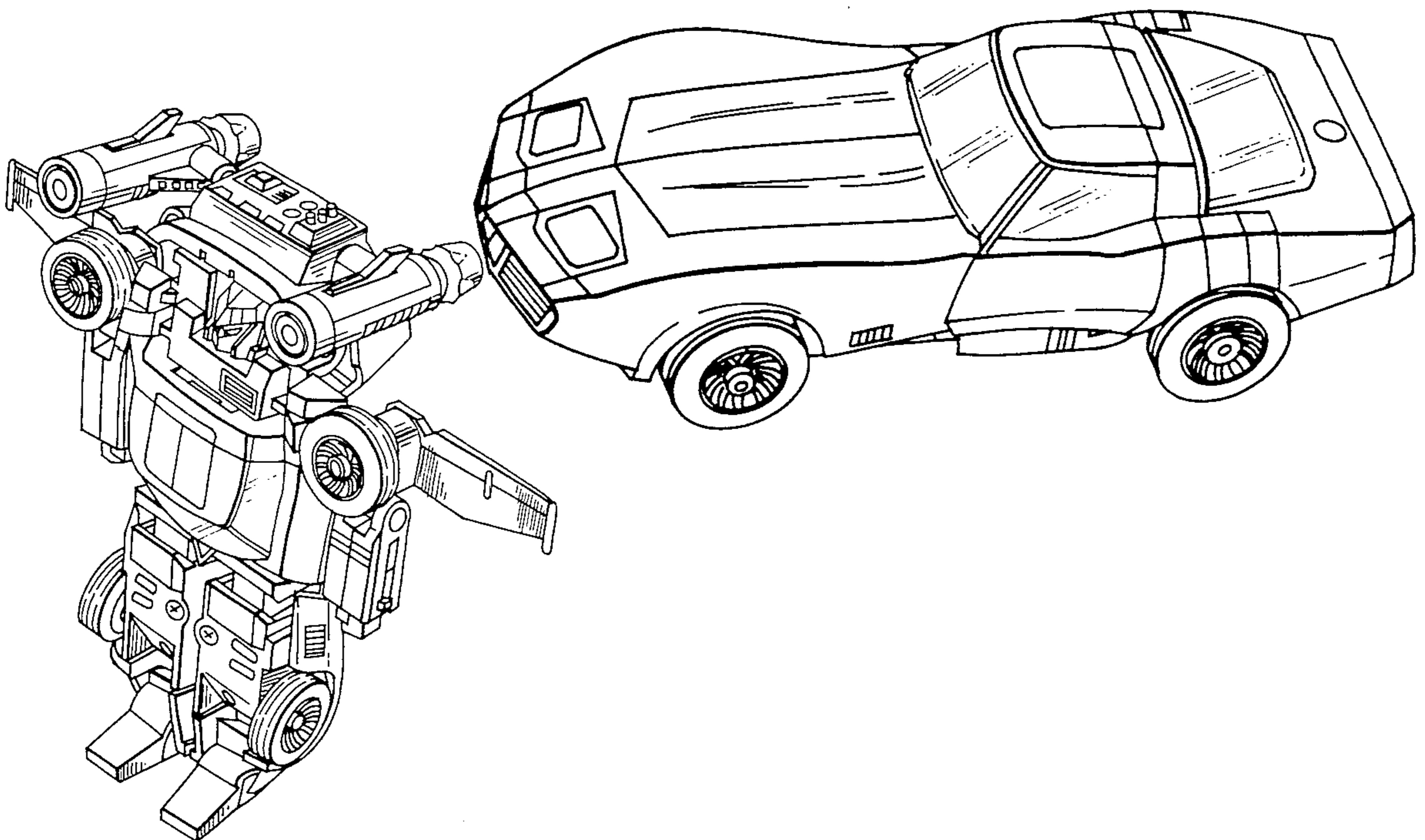

**FIG.1**

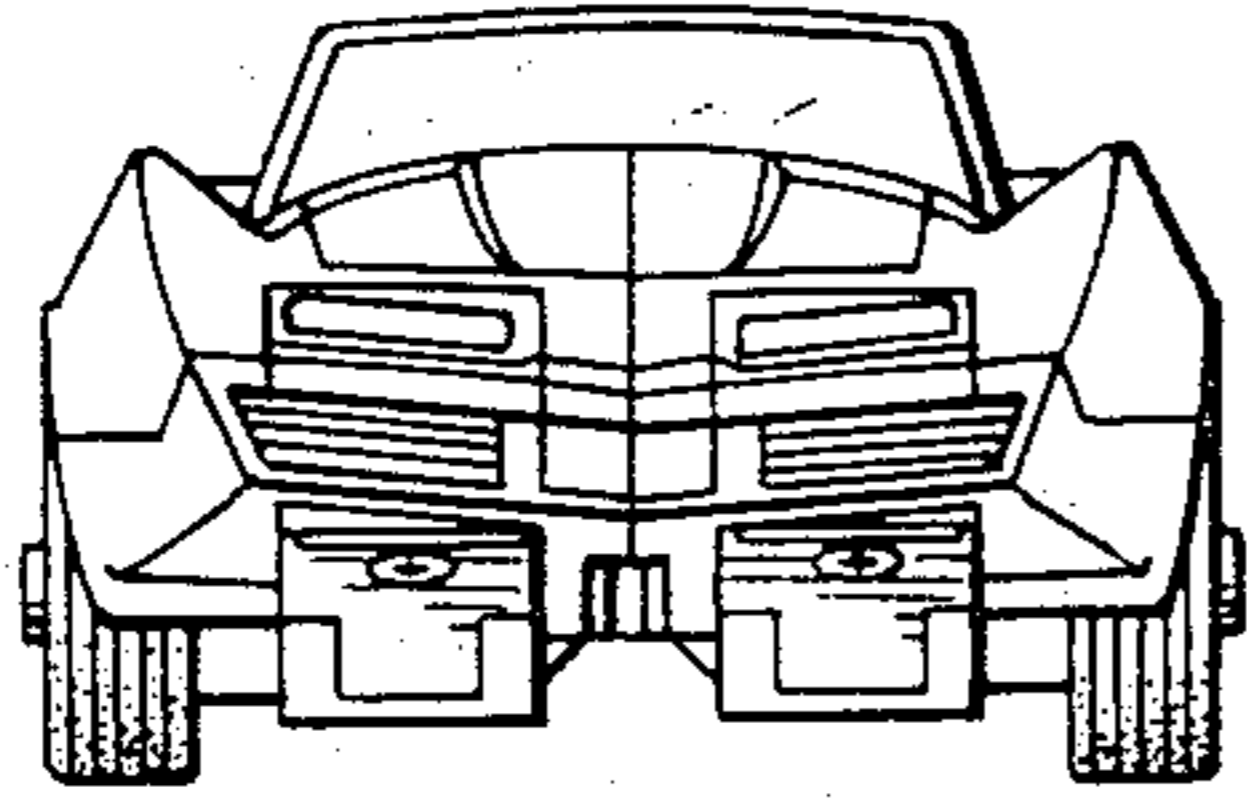

**FIG.2**

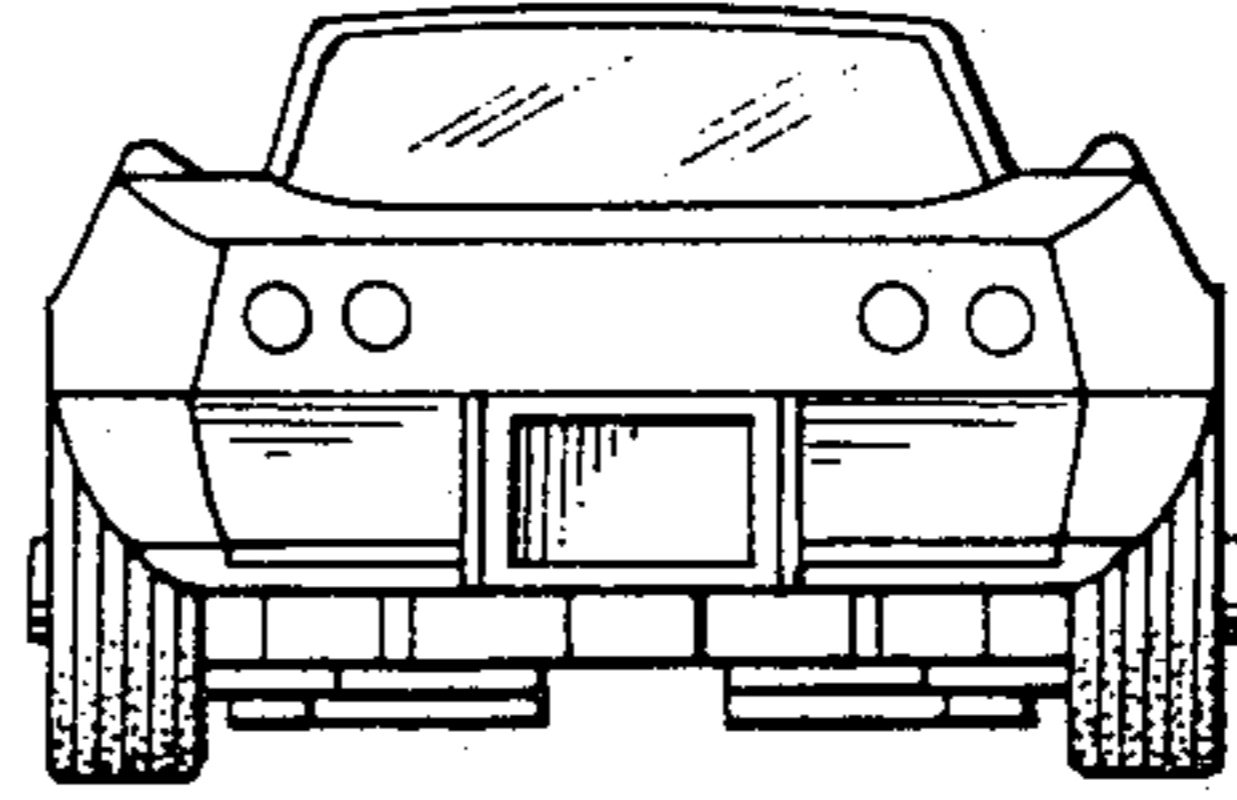

**FIG.3**

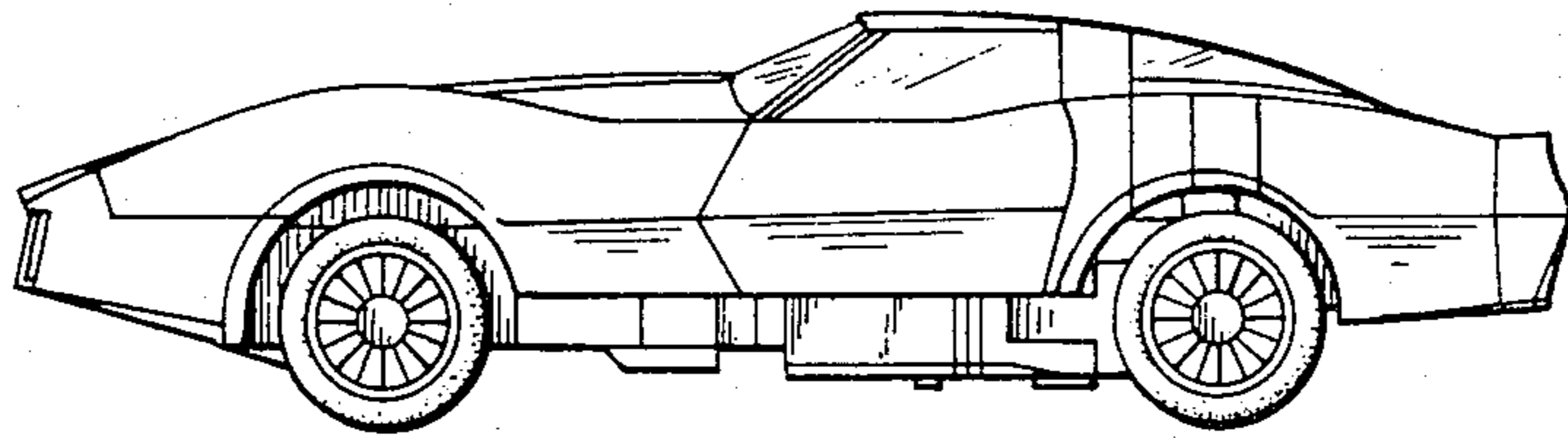

FIG.5

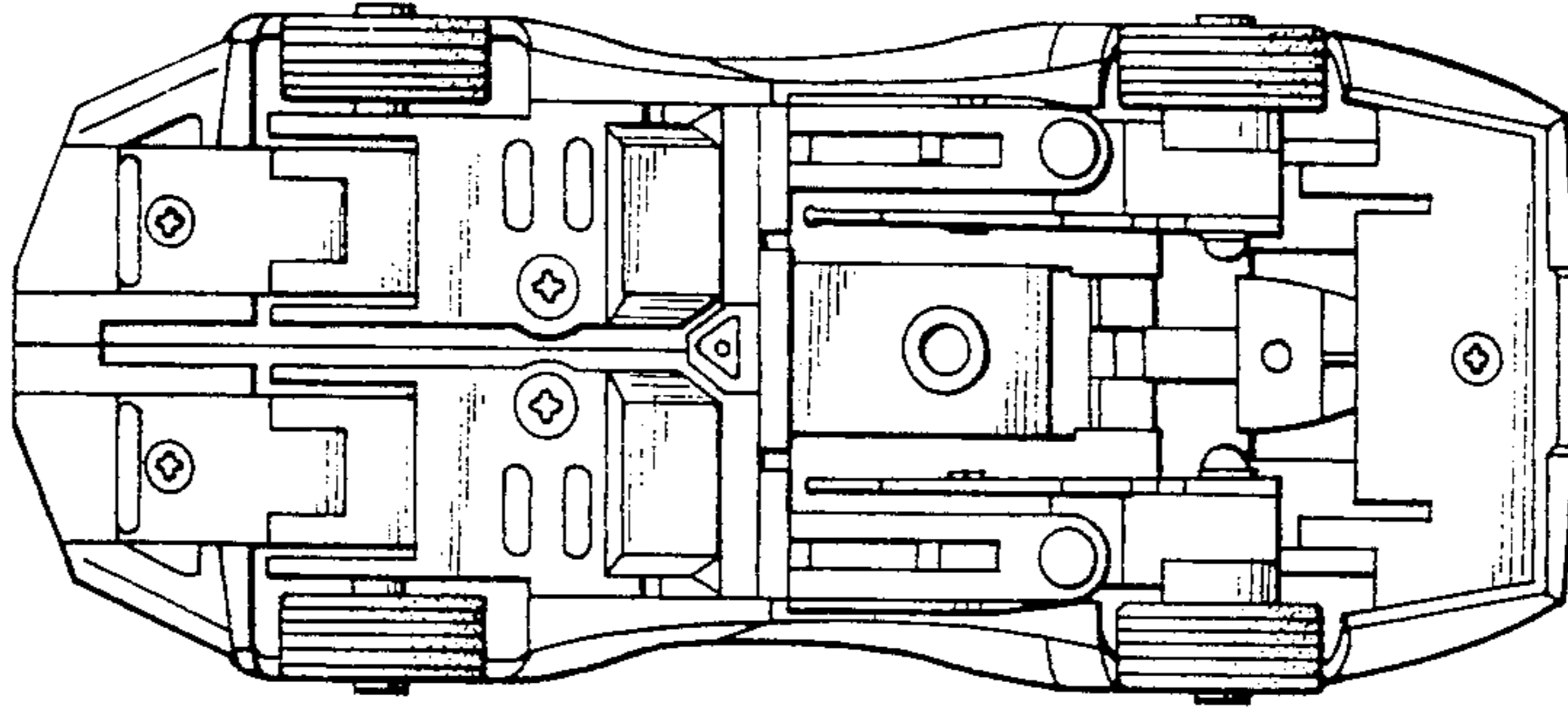

FIG.4

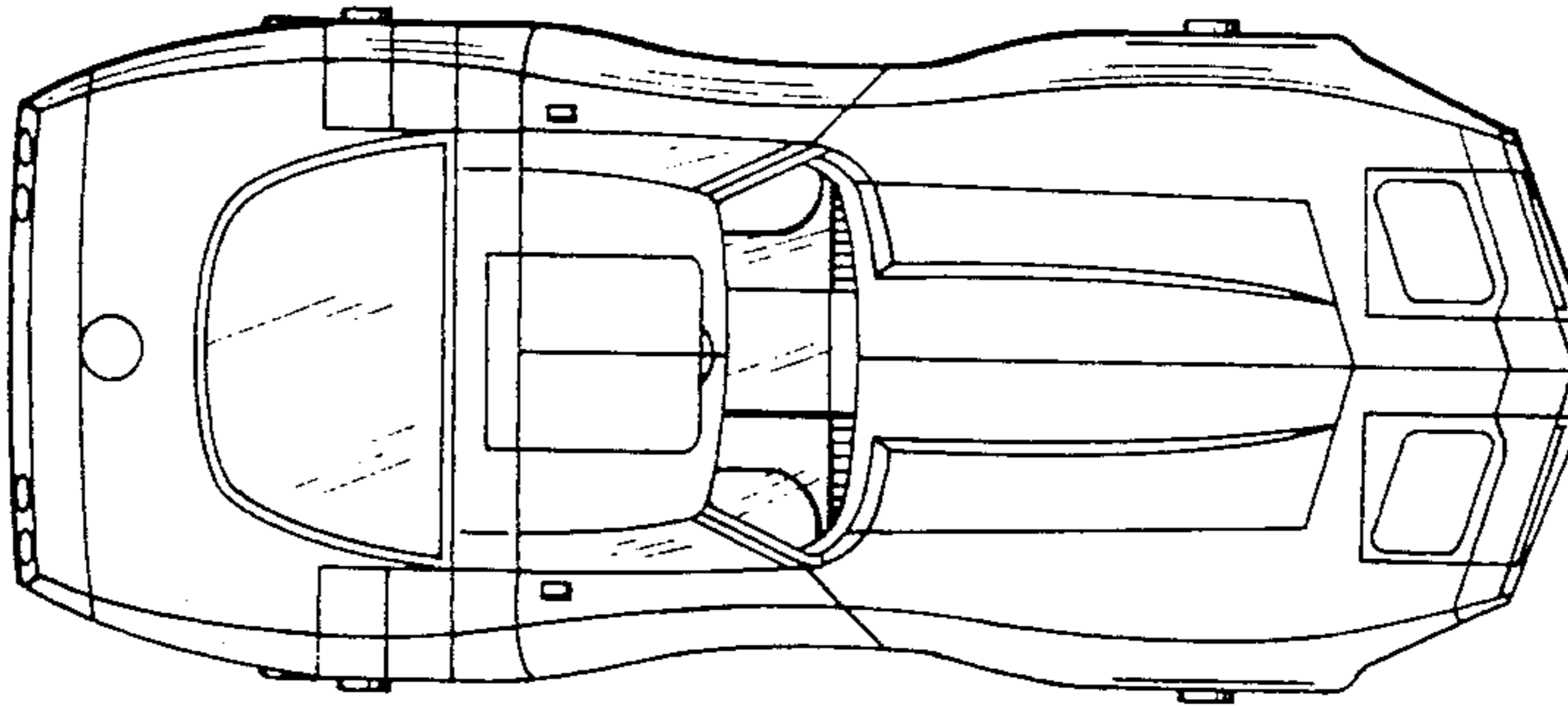

FIG.6

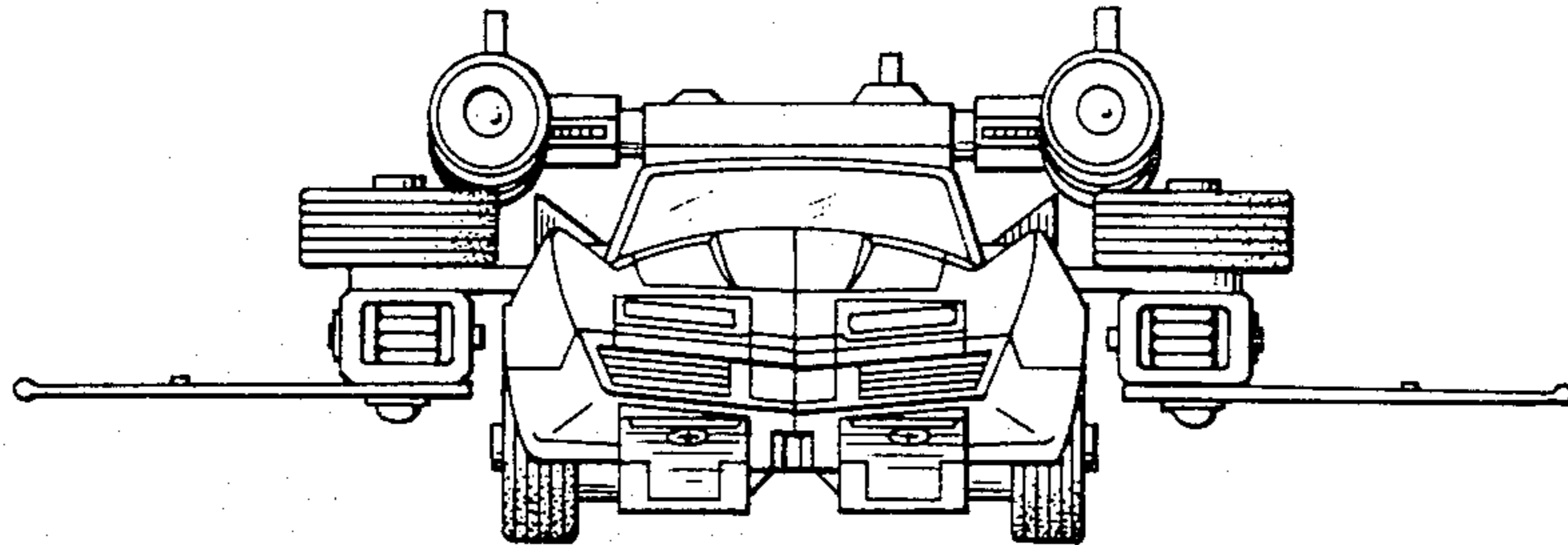

FIG.7

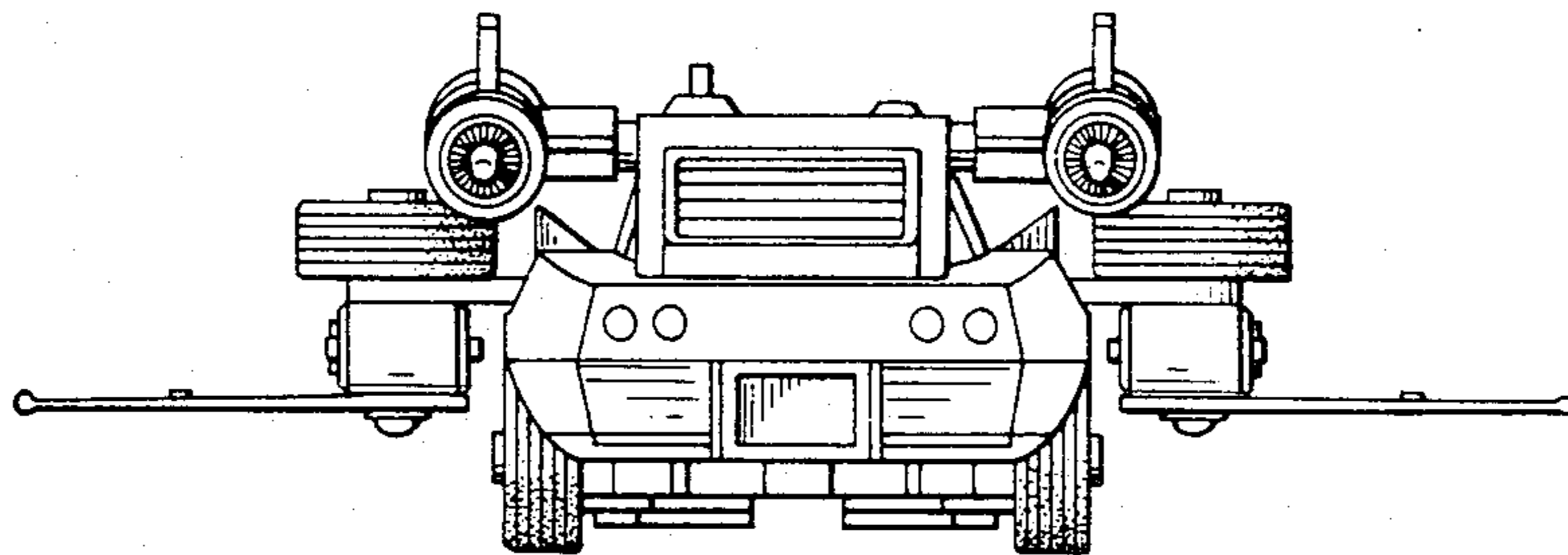
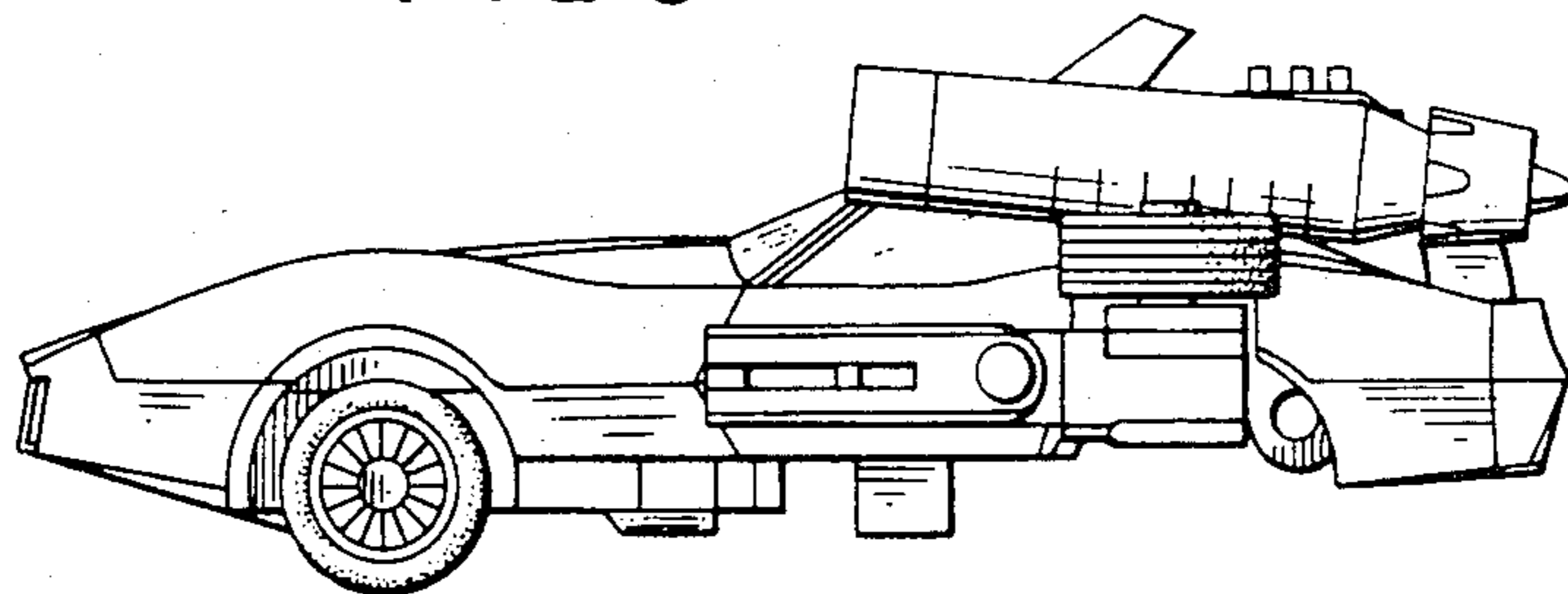

FIG.8



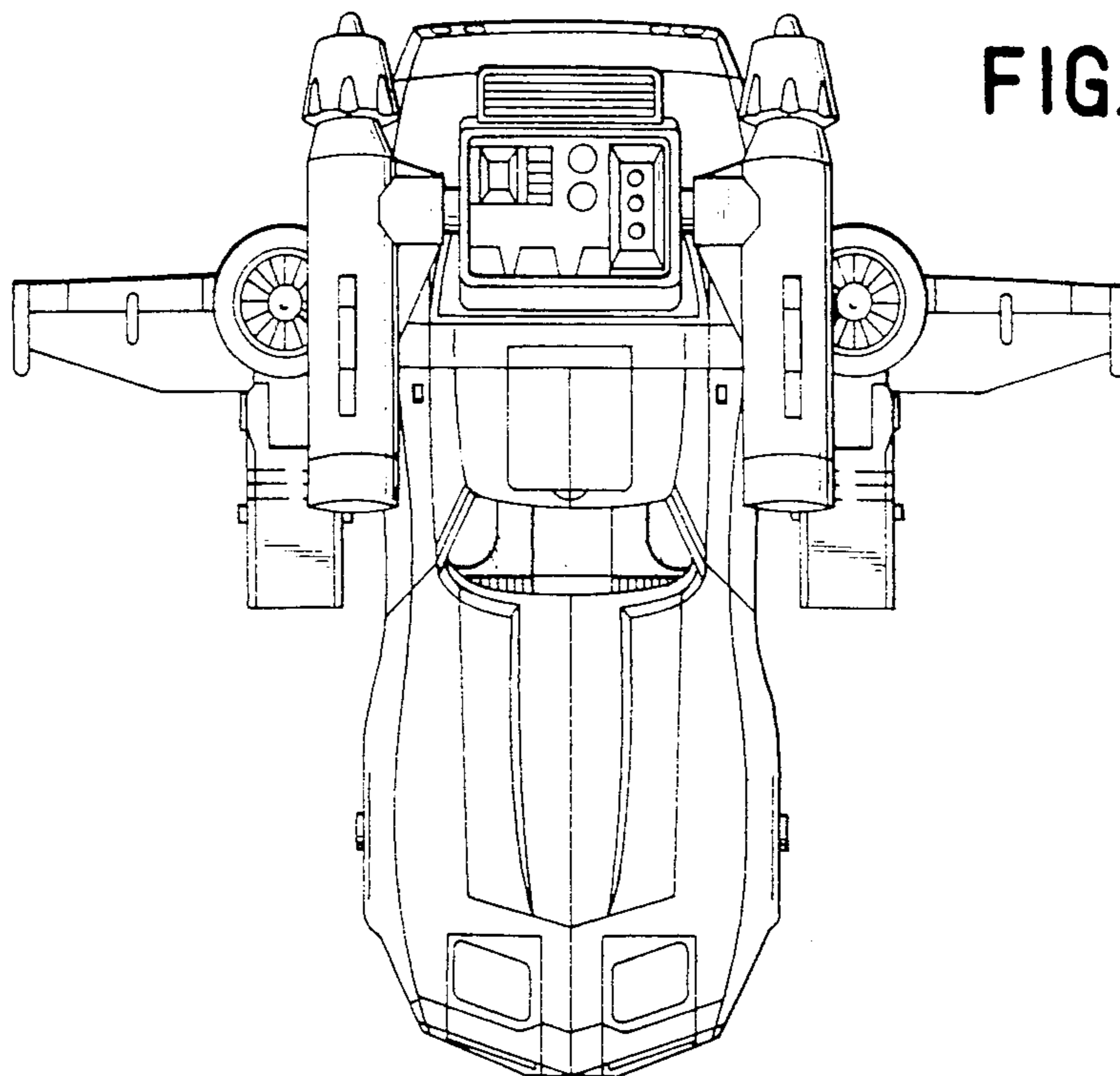

FIG.9

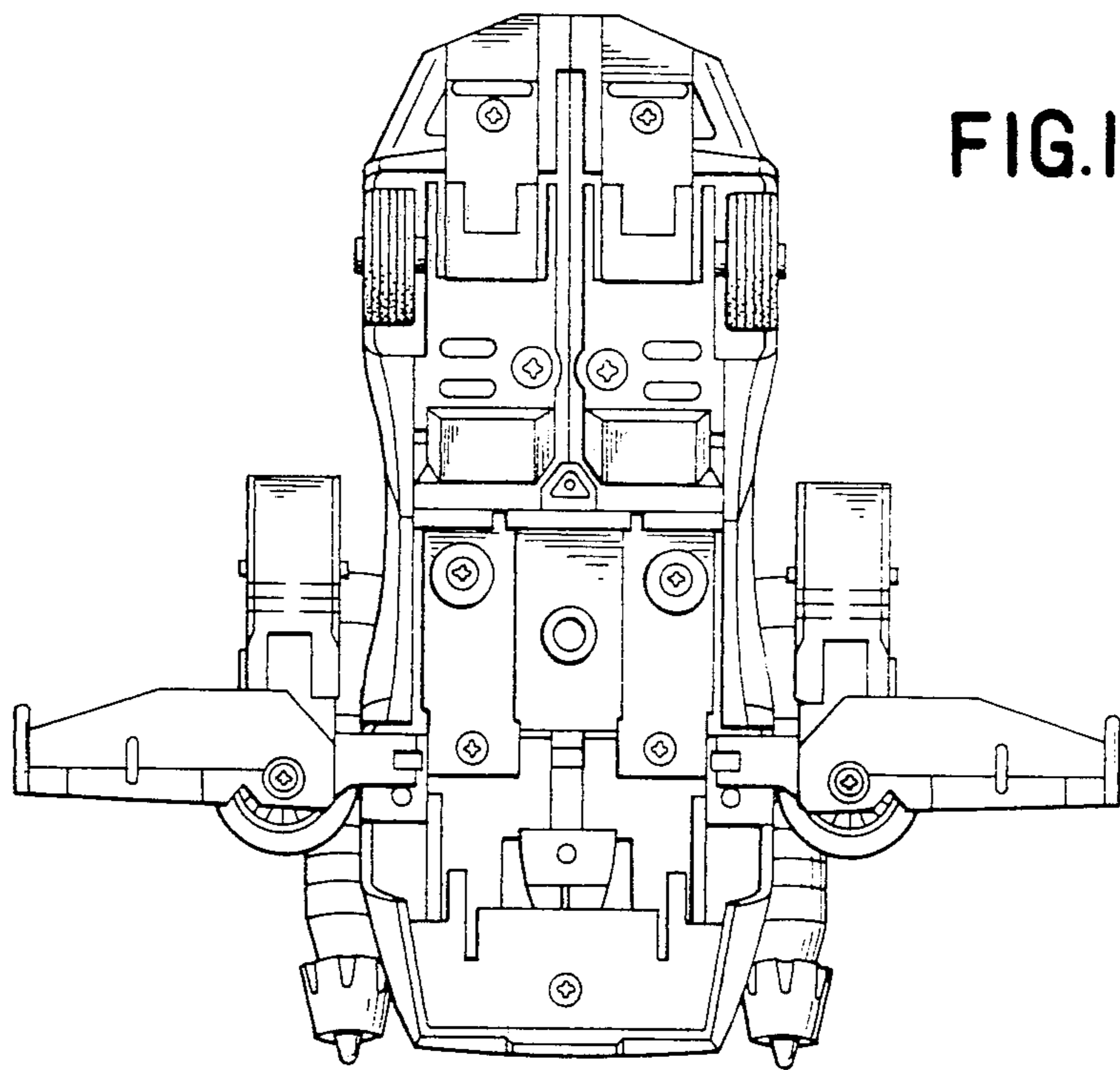

FIG.10

FIG.11

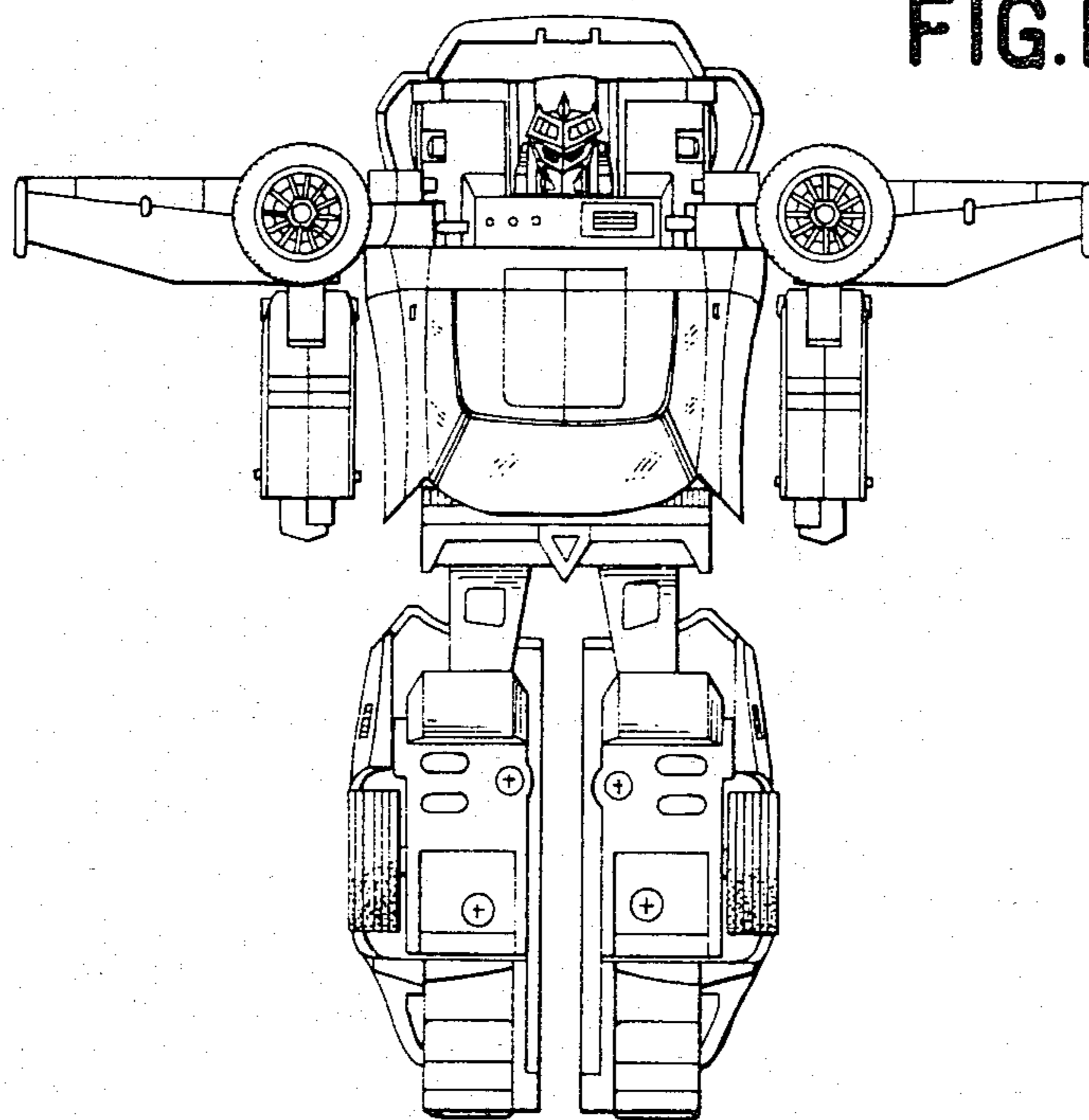
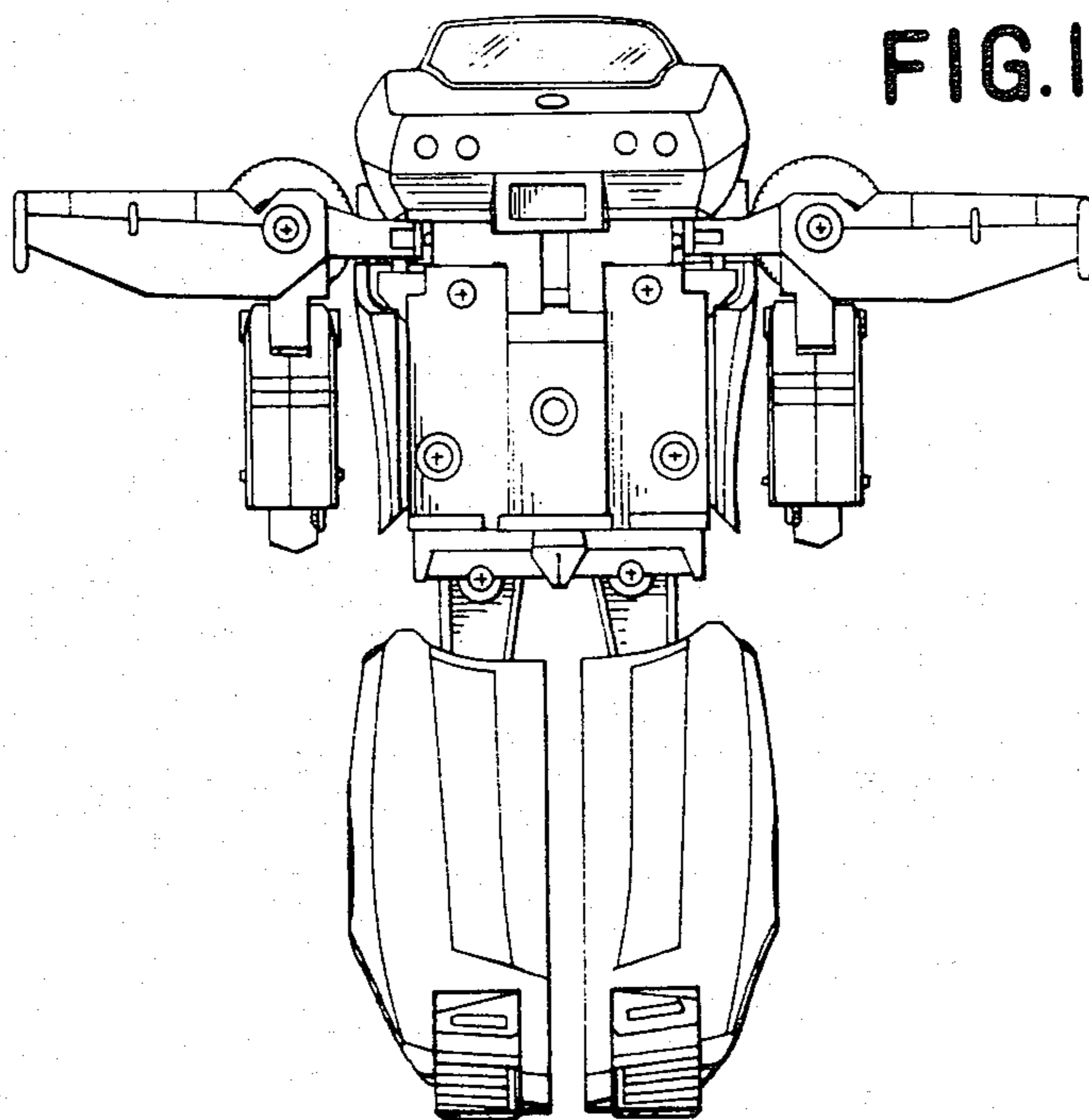

FIG.12



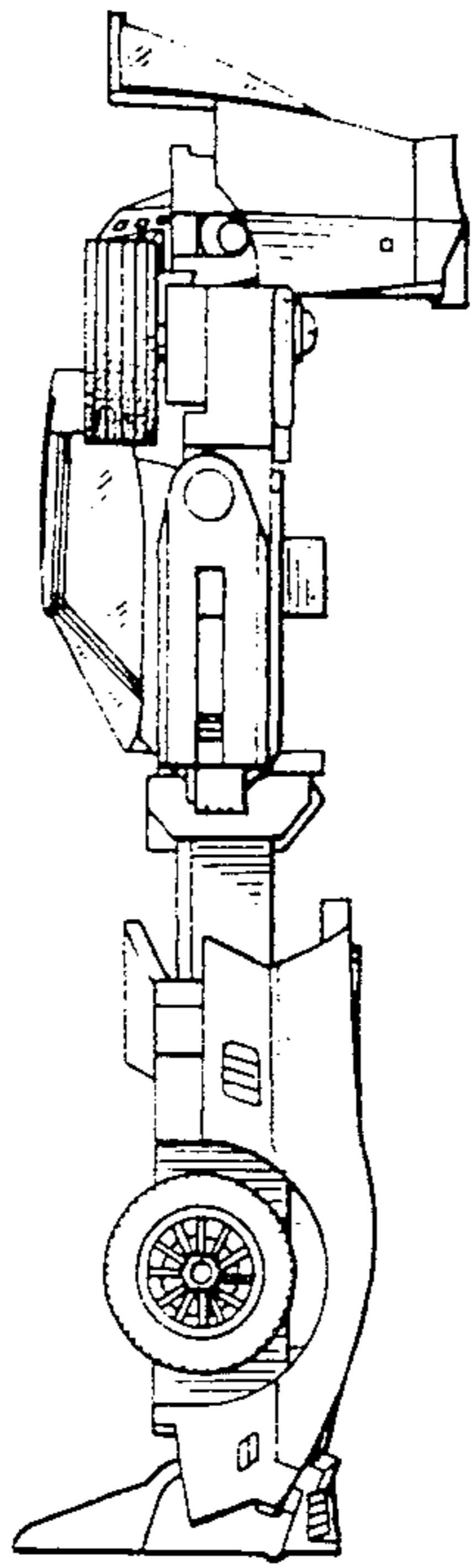

FIG.13

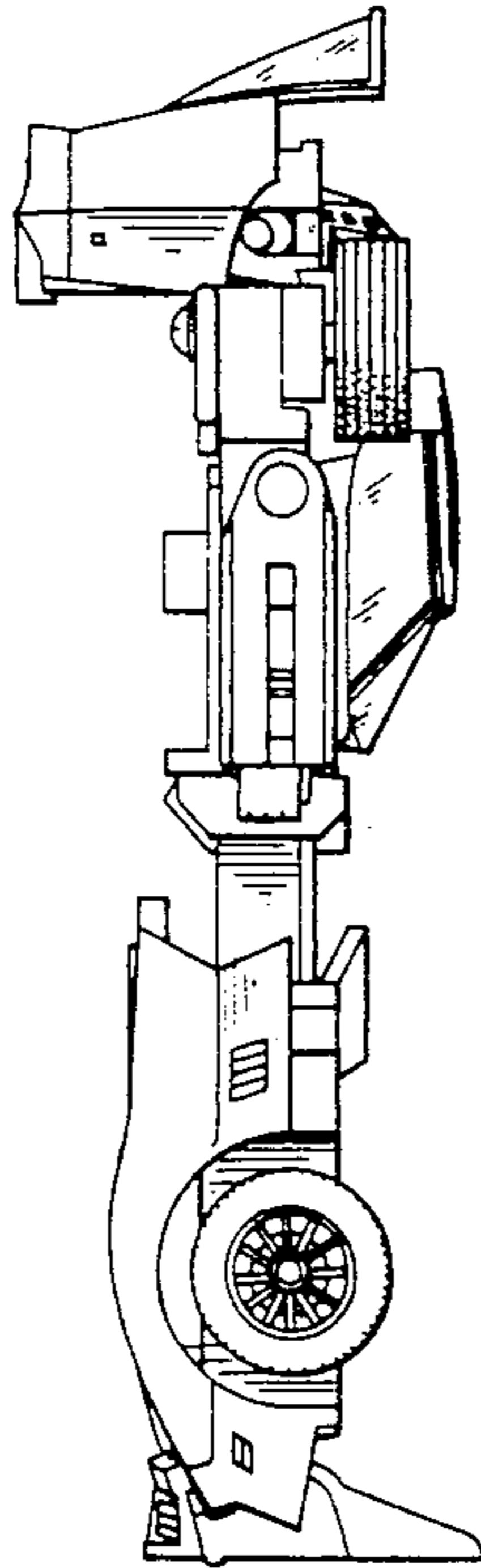

FIG.14

FIG. 15

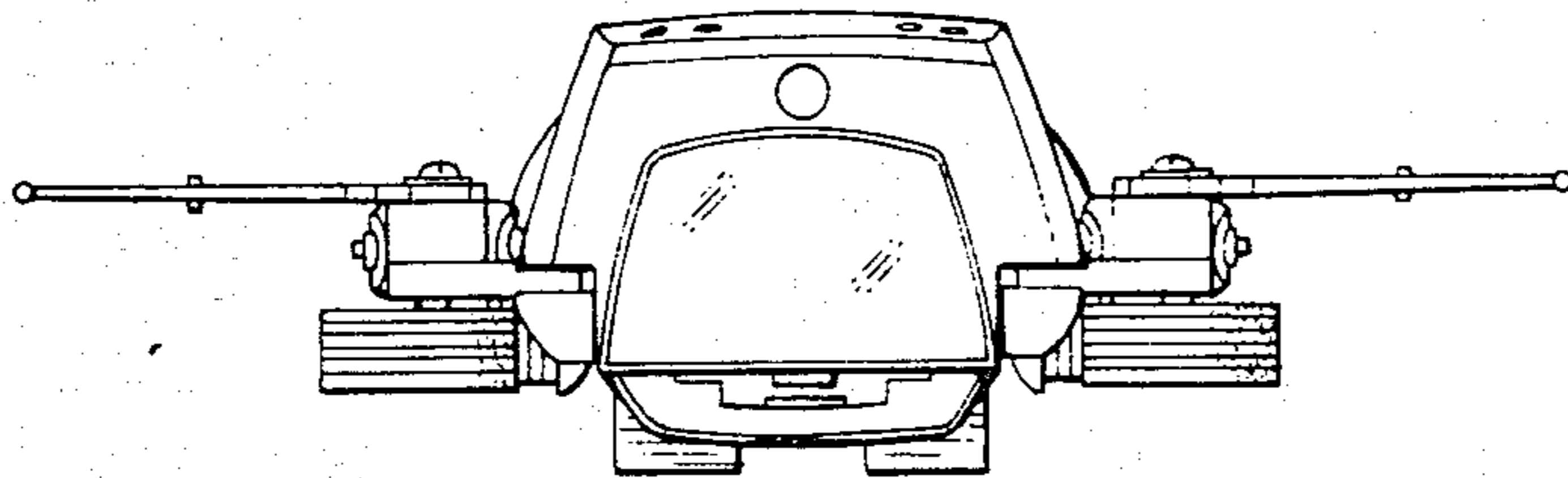

FIG. 16

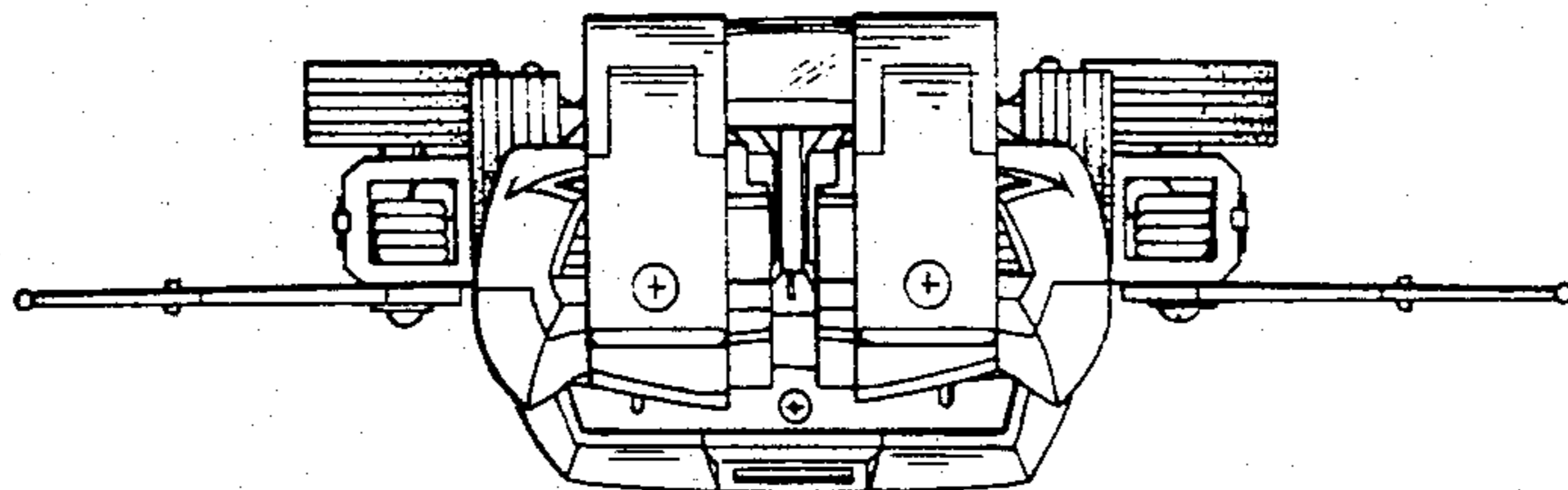



FIG. 17

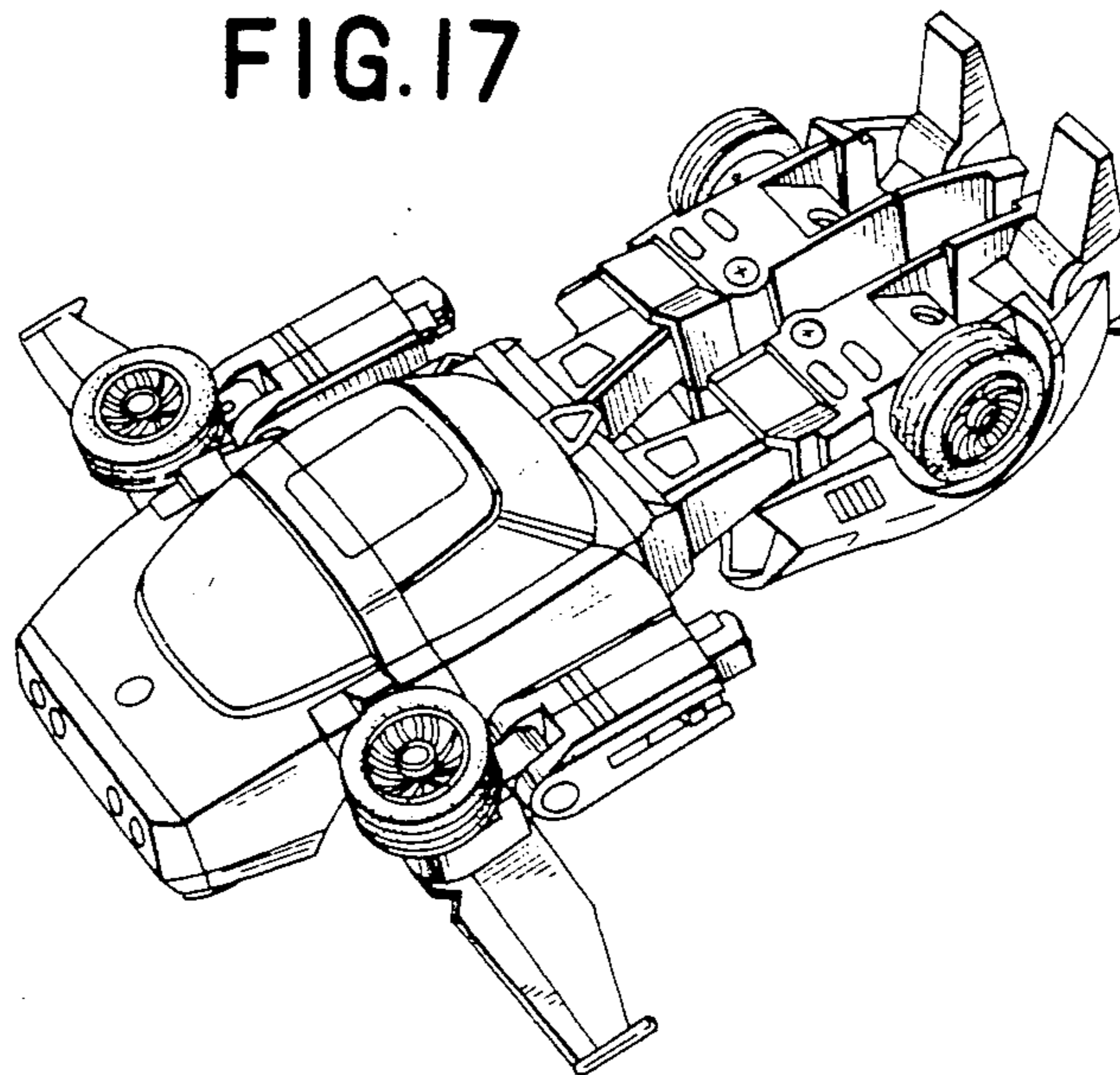

FIG. 18

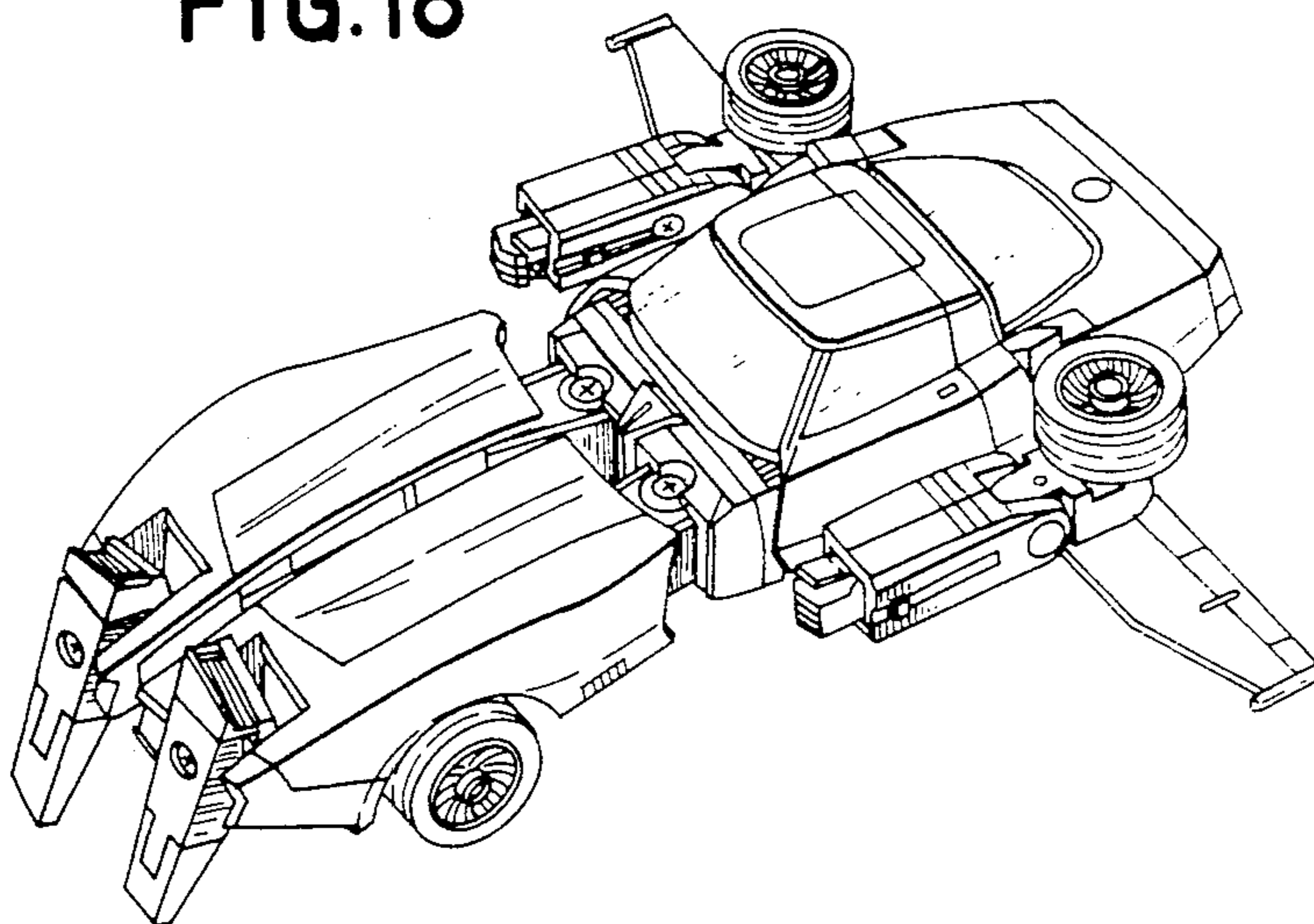

FIG.19

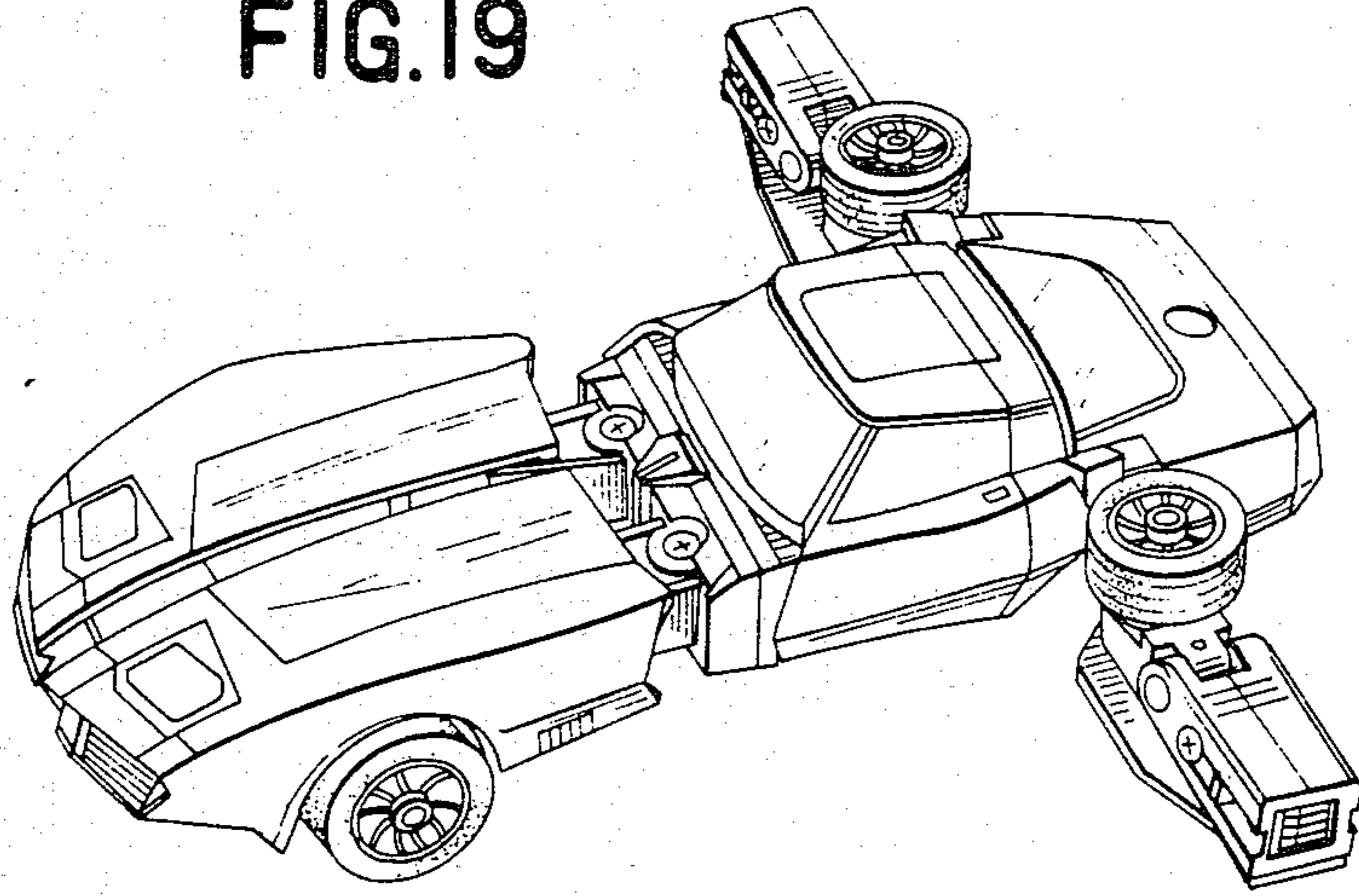

FIG.20

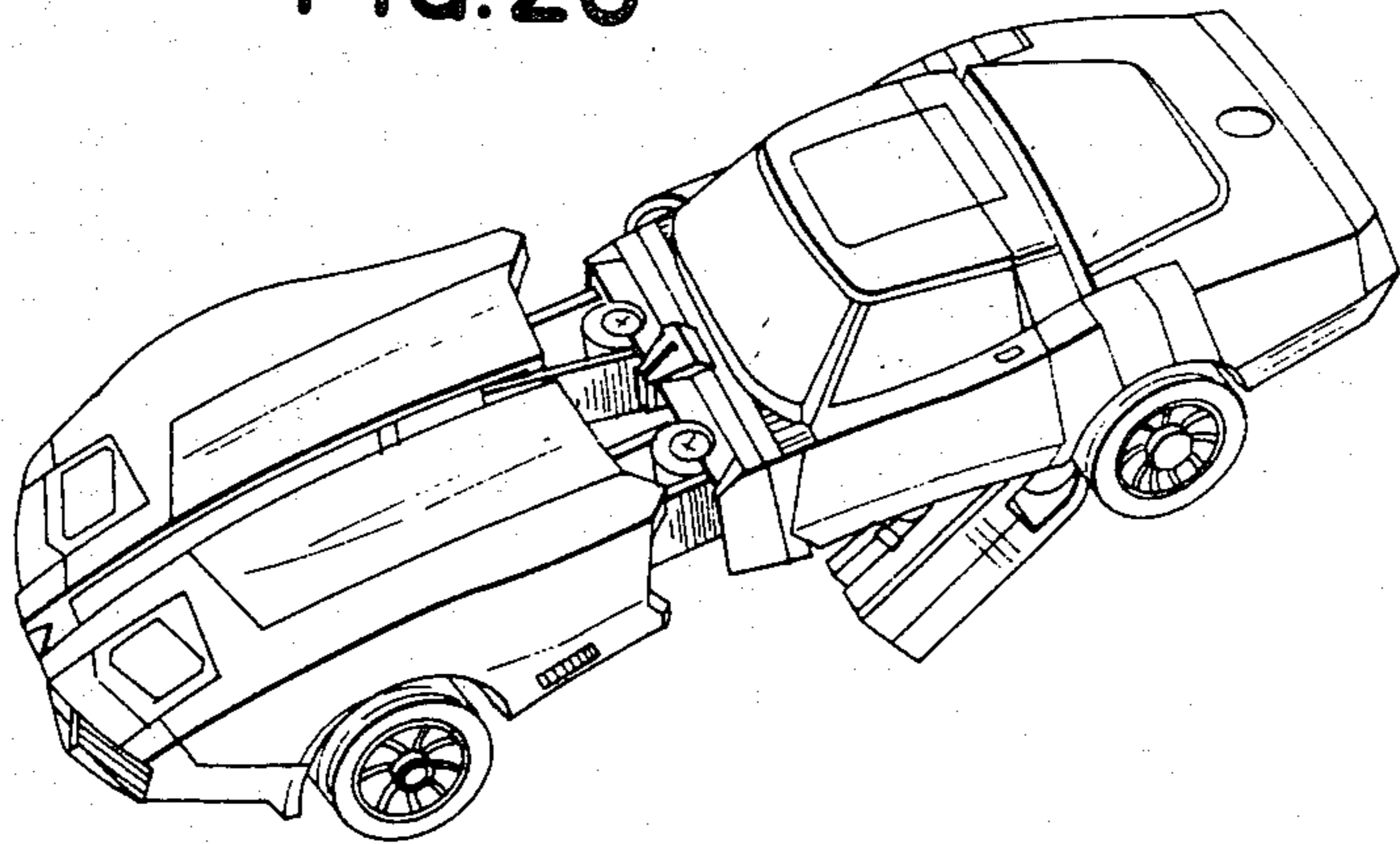

FIG. 21

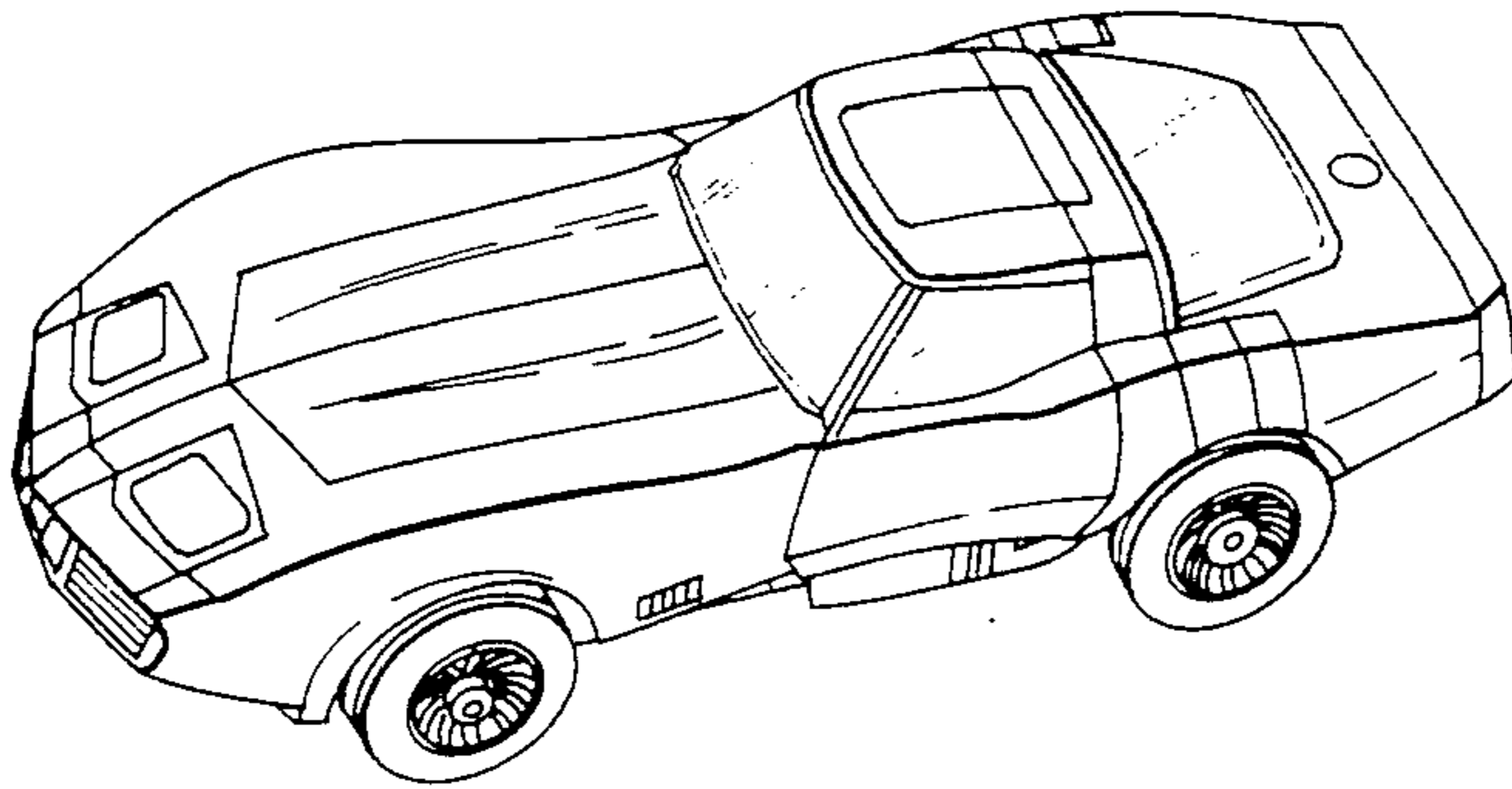

FIG. 22

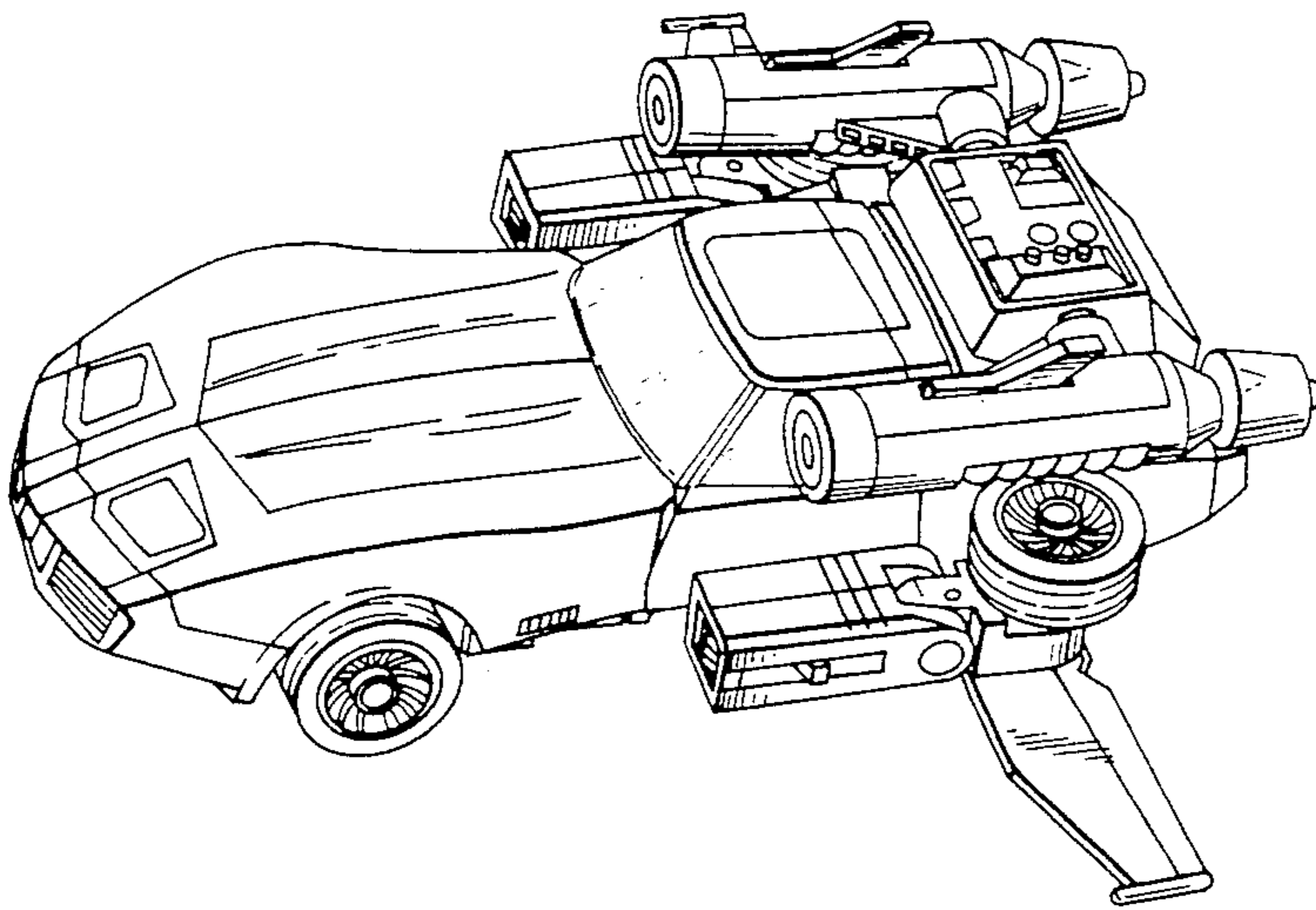

FIG. 23

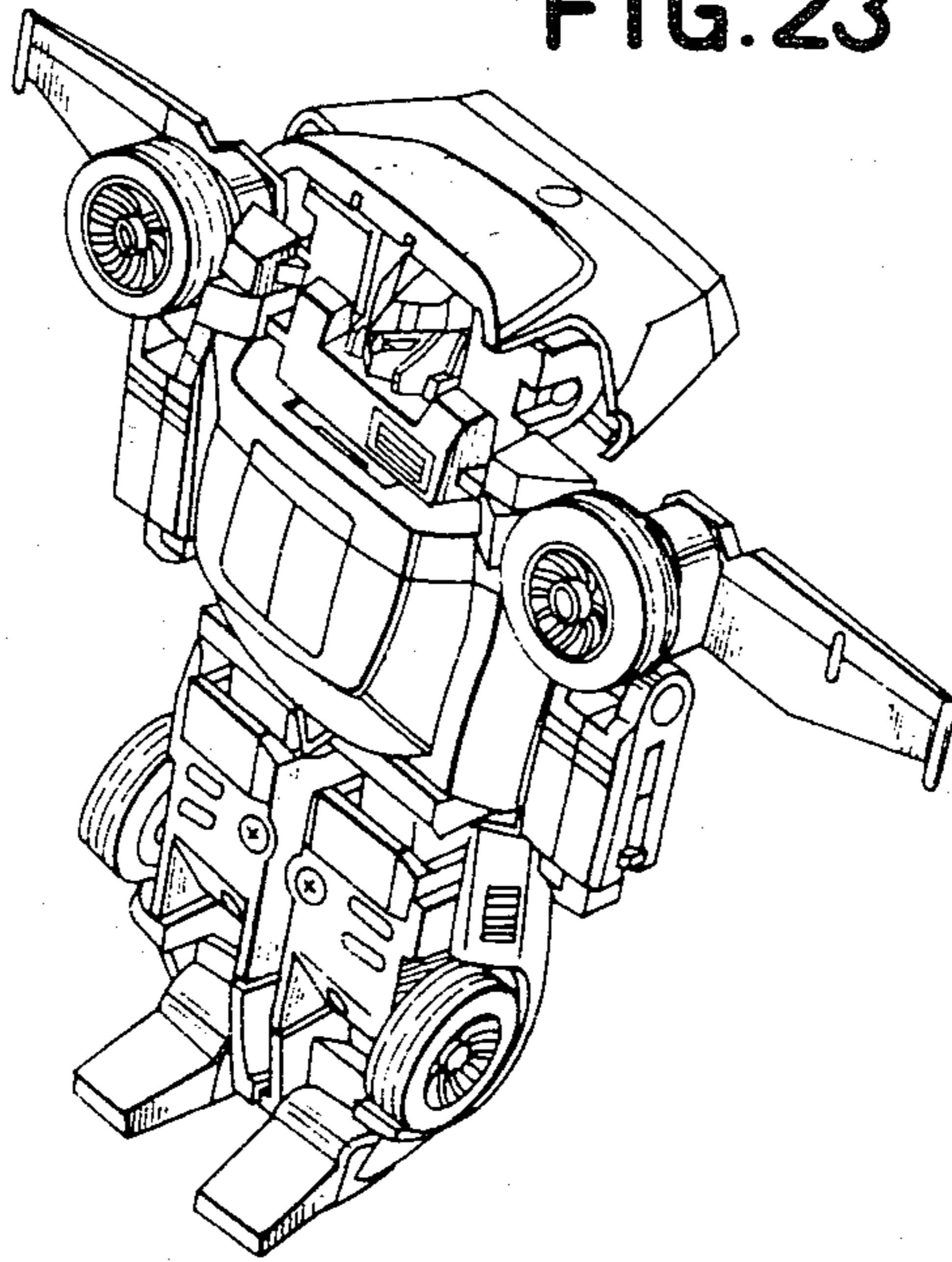

FIG. 24

