

[54] MOTORCYCLE

[75] Inventor: Karl H. Abe, Steinebach/Wörthsee, Fed. Rep. of Germany

[73] Assignee: Bayerische Motoren Werke A.G., Fed. Rep. of Germany

[**] Term: 14 Years

[21] Appl. No.: 544,289

[22] Filed: Oct. 21, 1983

[30] Foreign Application Priority Data

Apr. 22, 1983 [DE] Fed. Rep. of Germany ... MR 13423

[52] U.S. Cl. D12/110

[58] Field of Search D12/110; 180/219, 221, 180/229, 231

[56] References Cited

PUBLICATIONS

Cycle World, 2/82, pp. 60 and 61, Suzuki Motorcycle.

Cycle World, 4/82, p. 37, Honda CX 500 Motorcycle, bottom right side of page.

Cycle World, 5/82, p. 82, Suzuki XN 85 Motorcycle. Road & Track, 9/81, p. 102, Front Radiator Grille of BMW 323i, top left side of page.

Primary Examiner—James M. Gandy
Attorney, Agent, or Firm—Craig & Burns

[57] CLAIM

The ornamental design for a motorcycle, as shown.

DESCRIPTION

FIG. 1 is a perspective view from in front of and to the right of the motorcycle embodying my novel design; FIG. 2 is a perspective view from in front of and to the left thereof;

FIG. 3 is a left side elevational view thereof;

FIG. 4 is a right side elevational view thereof;

FIG. 5 is a front elevational view thereof;

FIG. 6 is a rear elevational view thereof; and

FIG. 7 is a top plan view thereof.

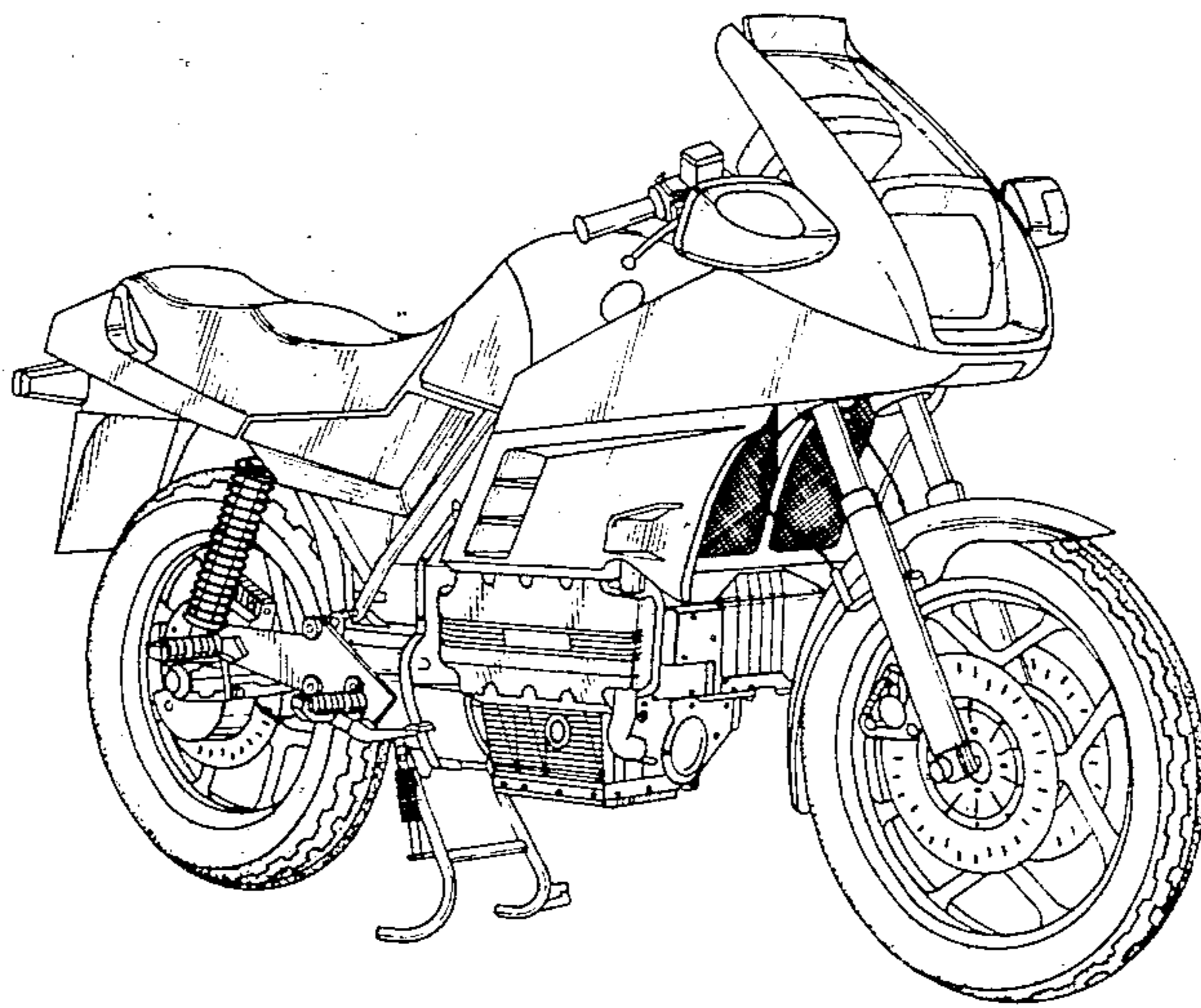

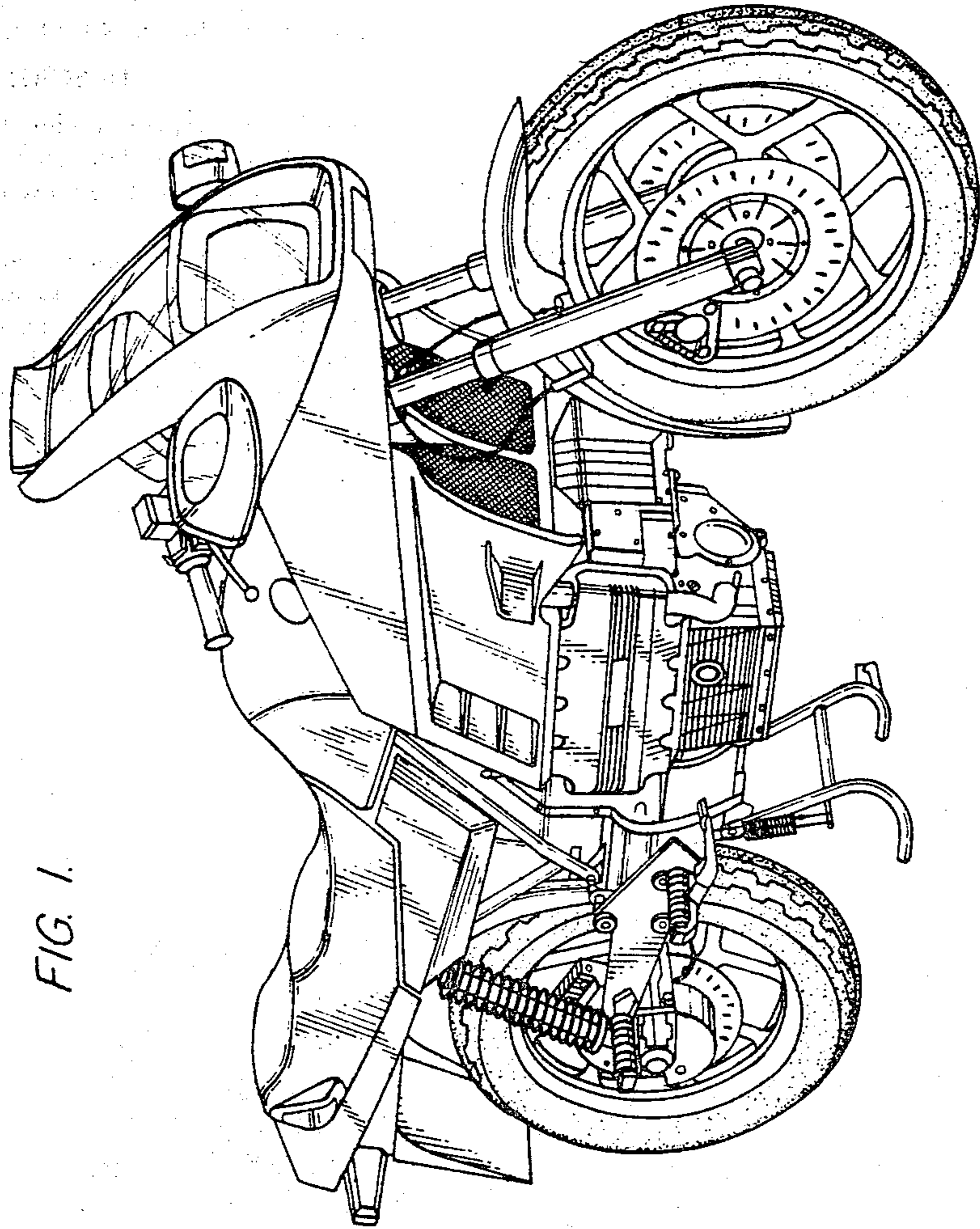

FIG. 1.

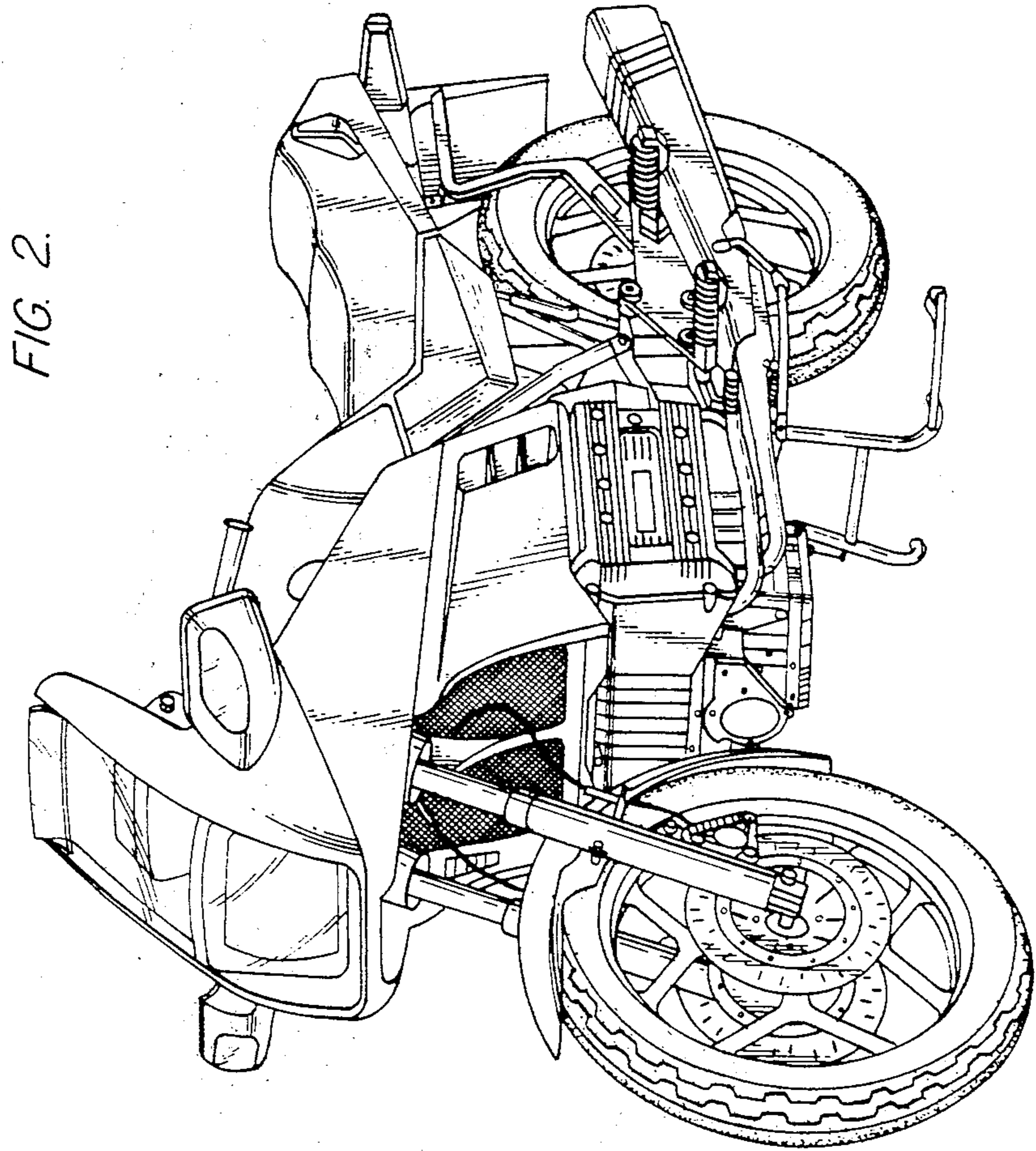

FIG. 2.

FIG. 3.

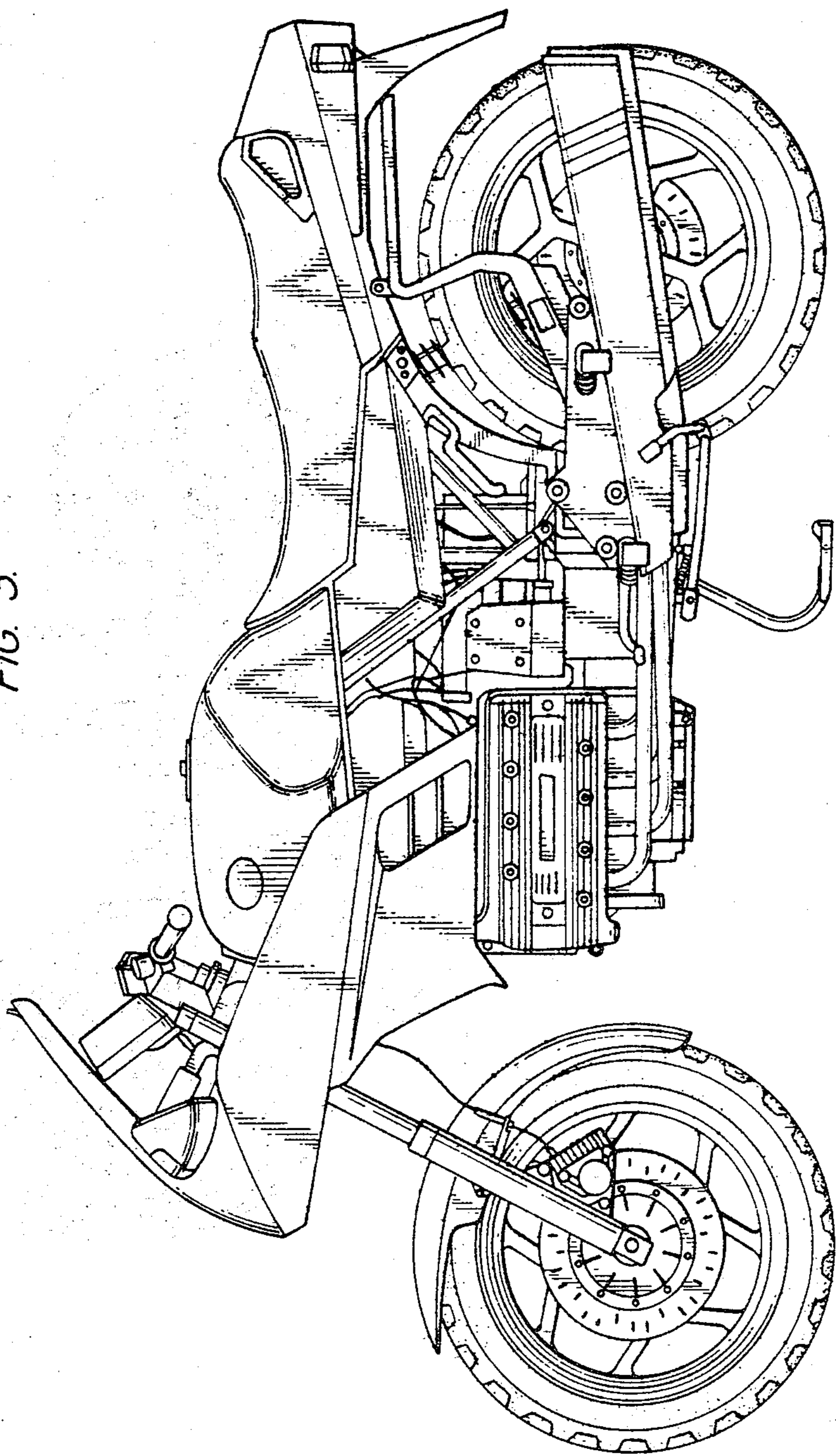

FIG. 4.

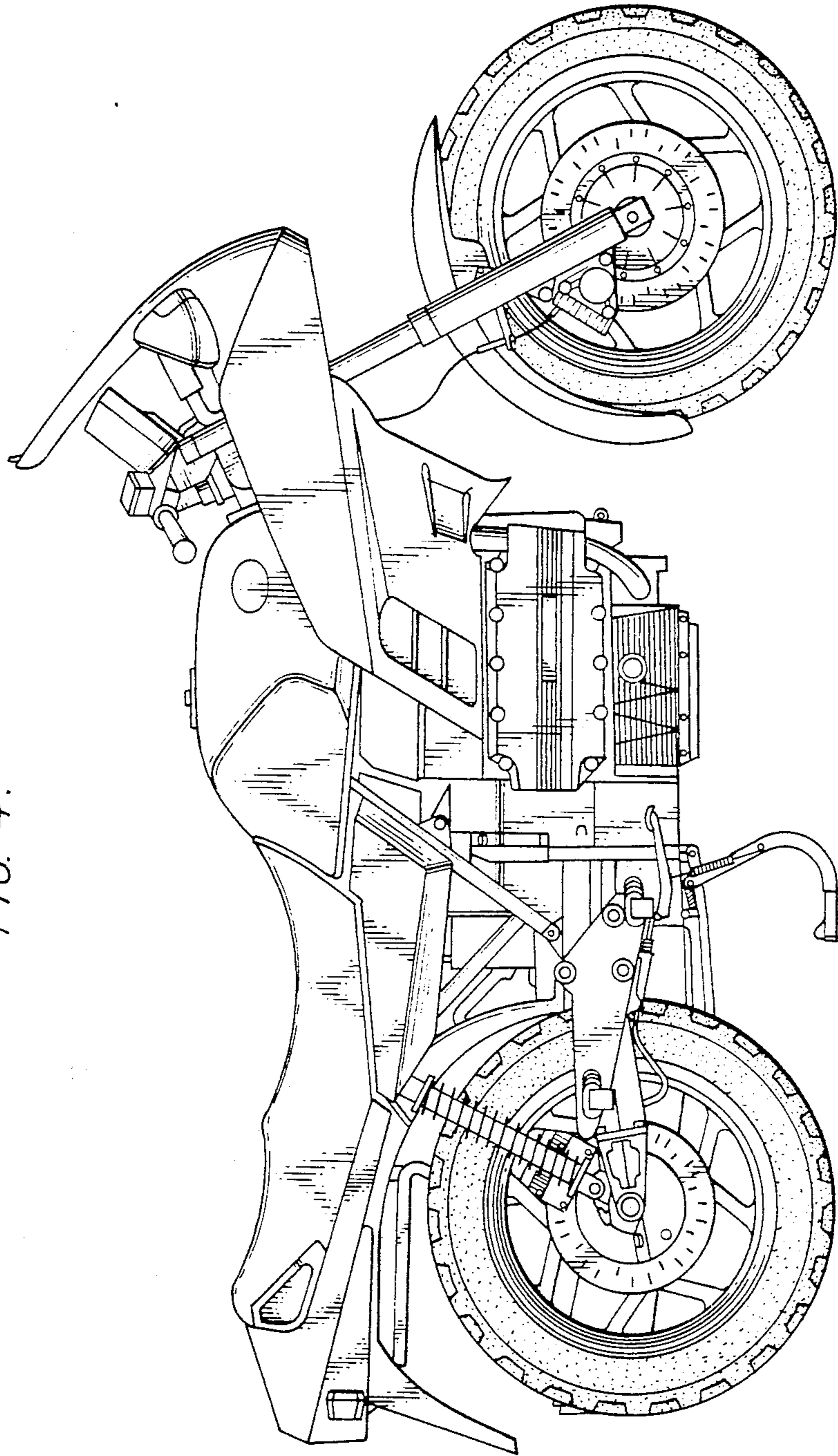

FIG. 6.

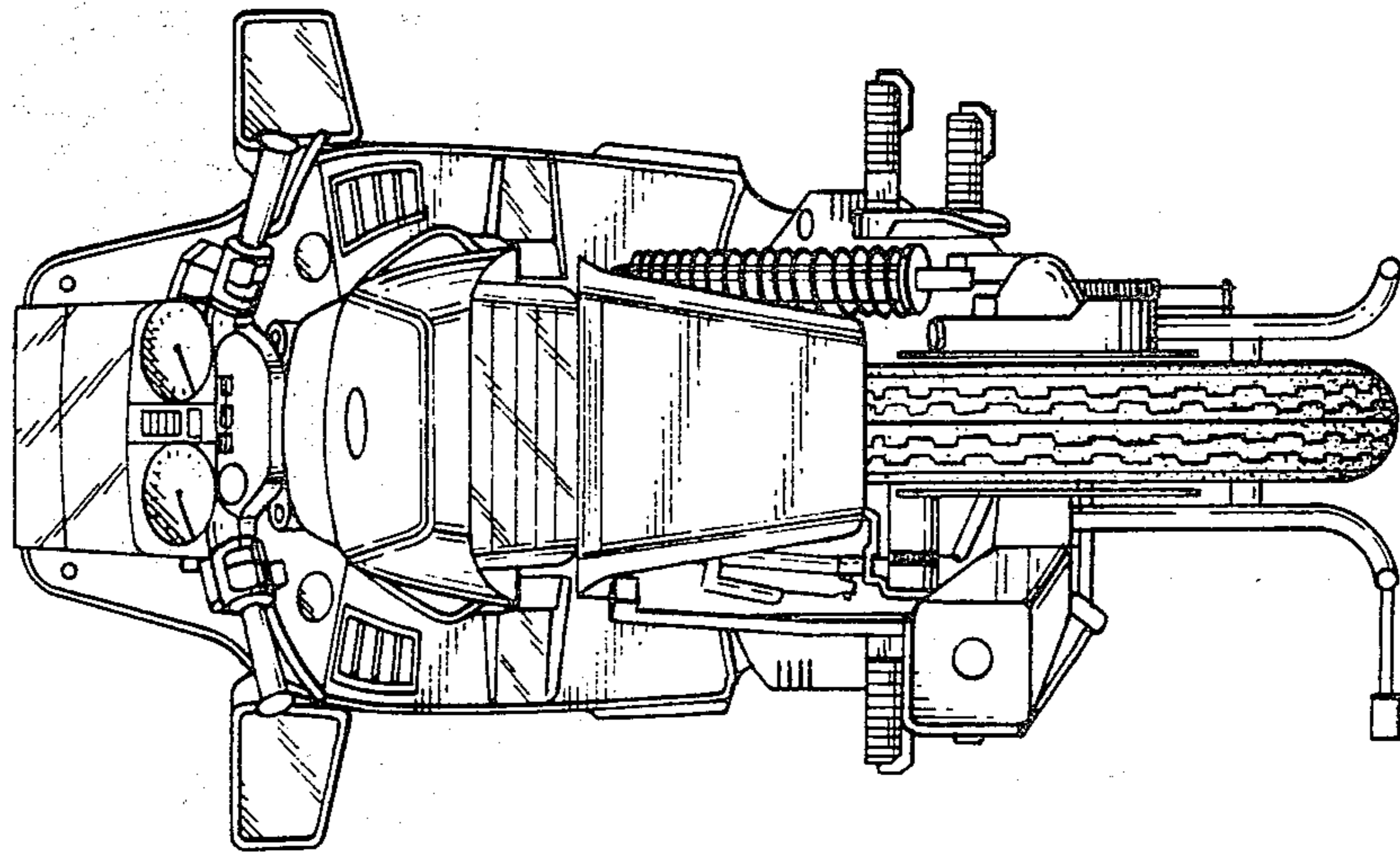
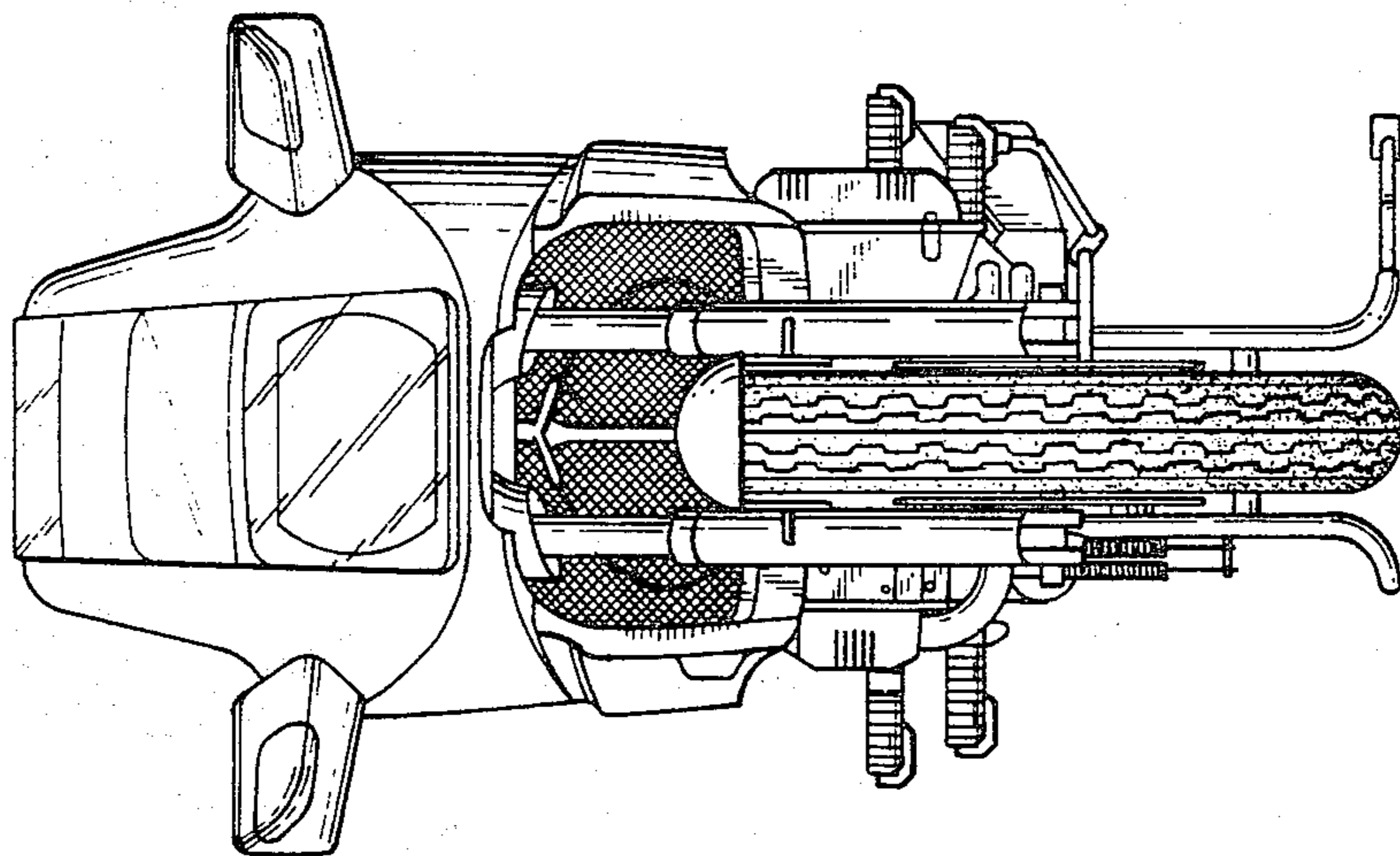

FIG. 5.



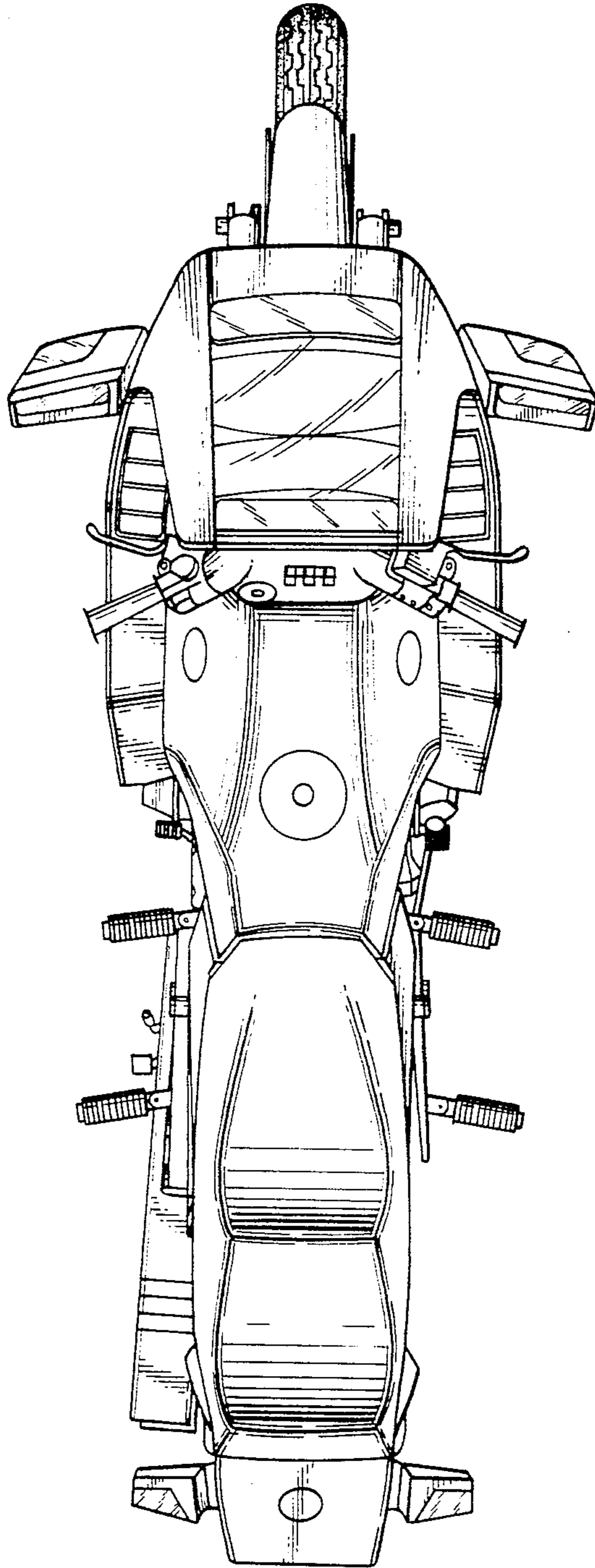

FIG. 7.