

[54] TIRE

[75] Inventors: Walter W. Hinkel, Massillon;  
Frederick W. Miller, Akron, both of Ohio

[73] Assignee: The Goodyear Tire & Rubber Company, Akron, Ohio

[\*\*] Term: 14 Years

[21] Appl. No.: 599,372

[22] Filed: Apr. 12, 1984

[52] U.S. Cl. .... D12/148

[58] Field of Search ..... D12/141-143,  
D12/146-151, 136, 137; 152/209 R, 209 D

[56] References Cited

PUBLICATIONS

1981 Tread Design Guide, p. 124, Centennial Tradition LT Radial Traction Tire, top center of page.

1981 Tread Design Guide, p. 134, Dunlop Radial Rover LT Highway Tire, top center of page.

1981 Tread Design Guide, p. 167, Remington Wide Brute Radial AP Tire, second row up from bottom, left side of page.

Primary Examiner—James M. Gandy  
Attorney, Agent, or Firm—L. R. Drayer

[57] CLAIM

The ornamental design for a tire, as shown and described.

DESCRIPTION

FIG. 1 is a perspective view of a tire showing our new design it being understood that the tread pattern is repeated throughout the circumference of the tire, the opposite side being substantially the same as that shown; FIG. 2 is a front elevational view thereof; and FIG. 3 is an enlarged fragmentary front plan view thereof.

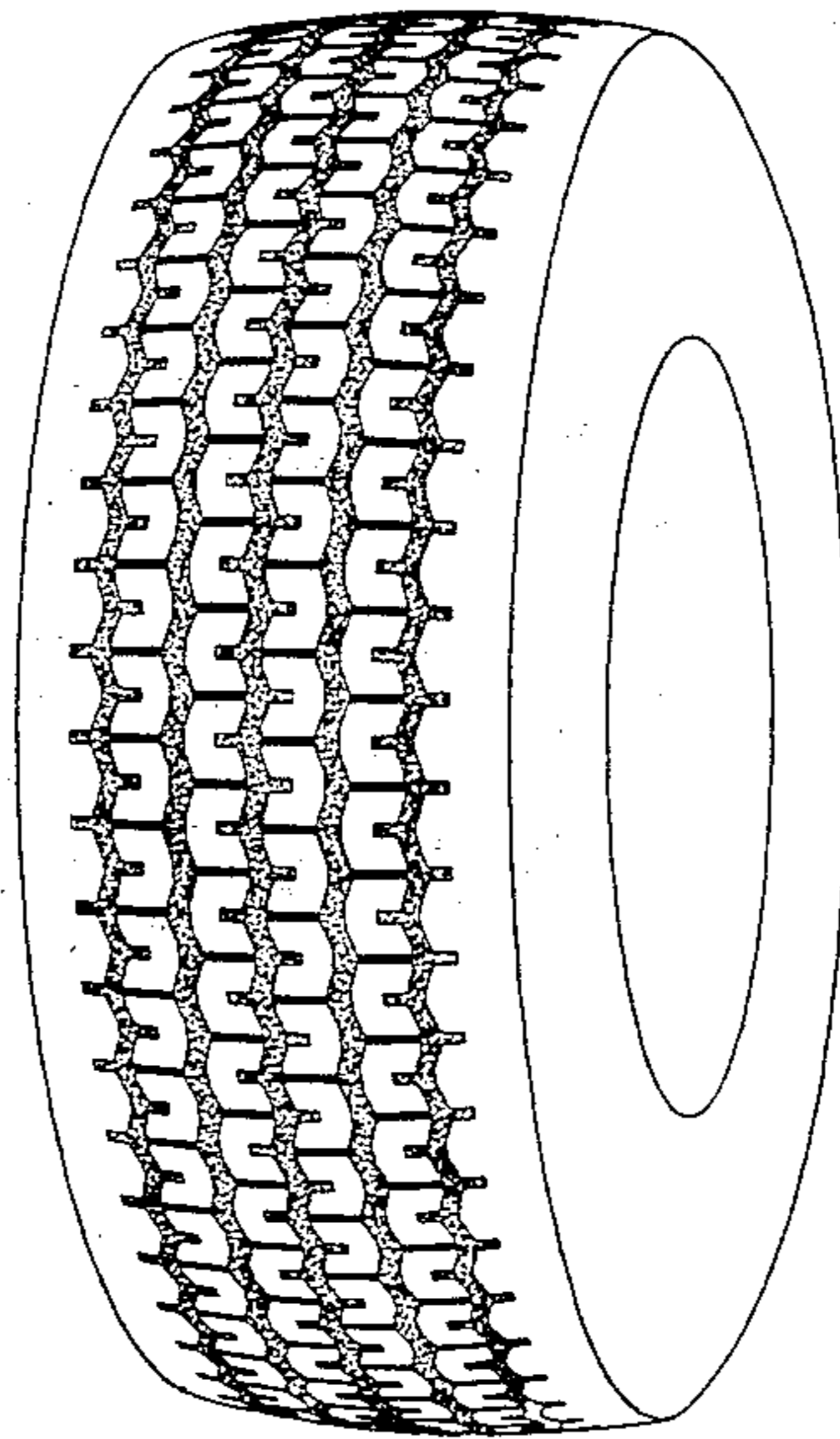

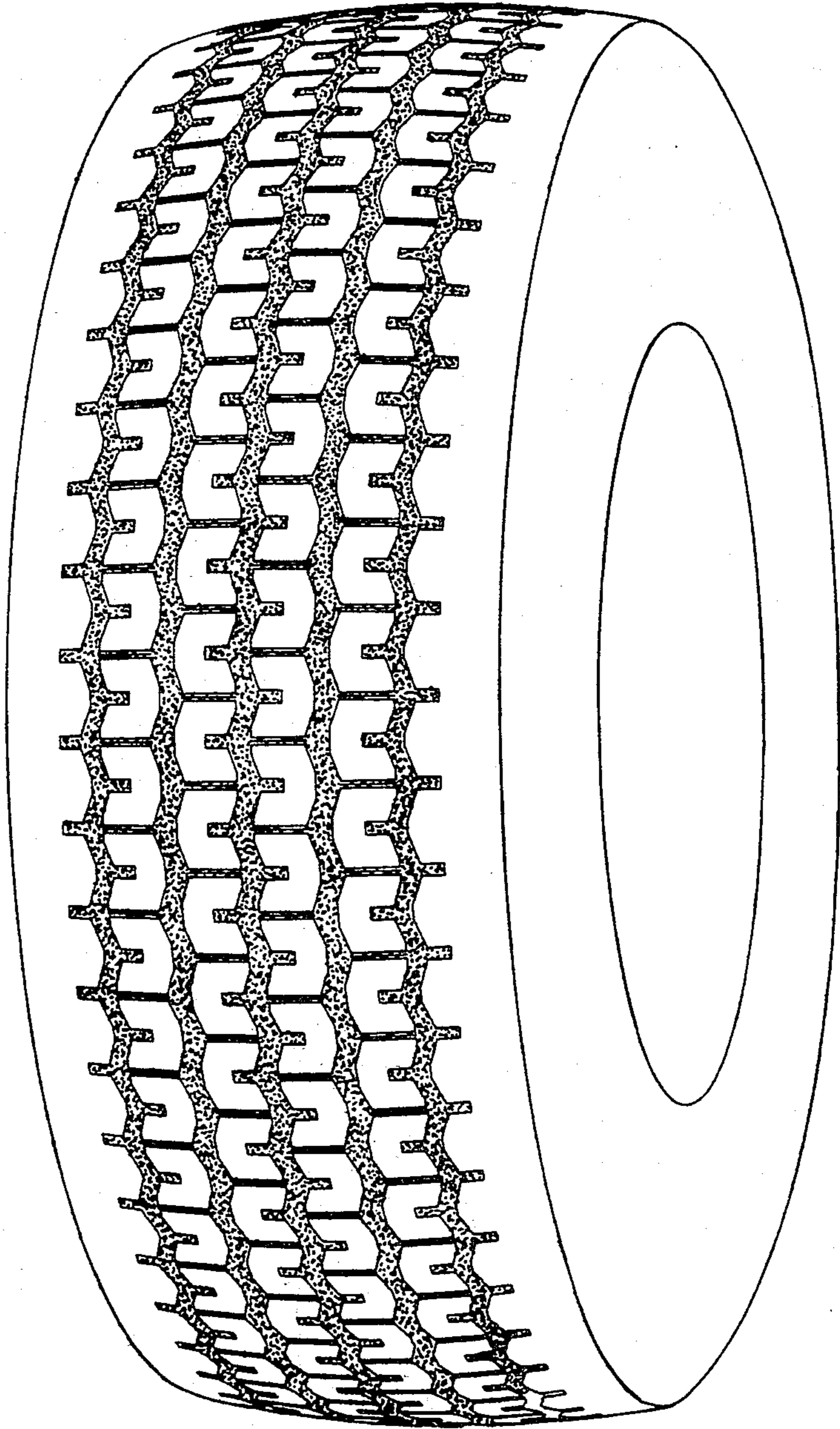

FIG. 1

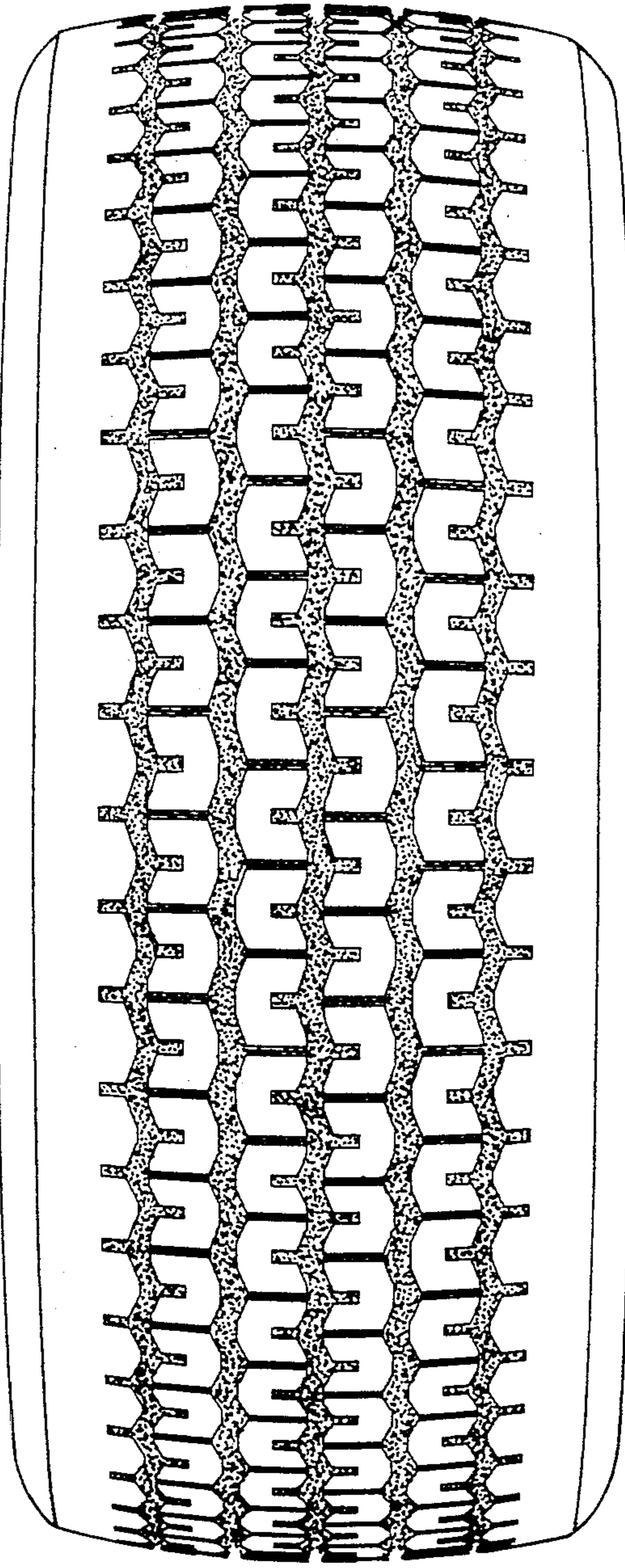

FIG. 2

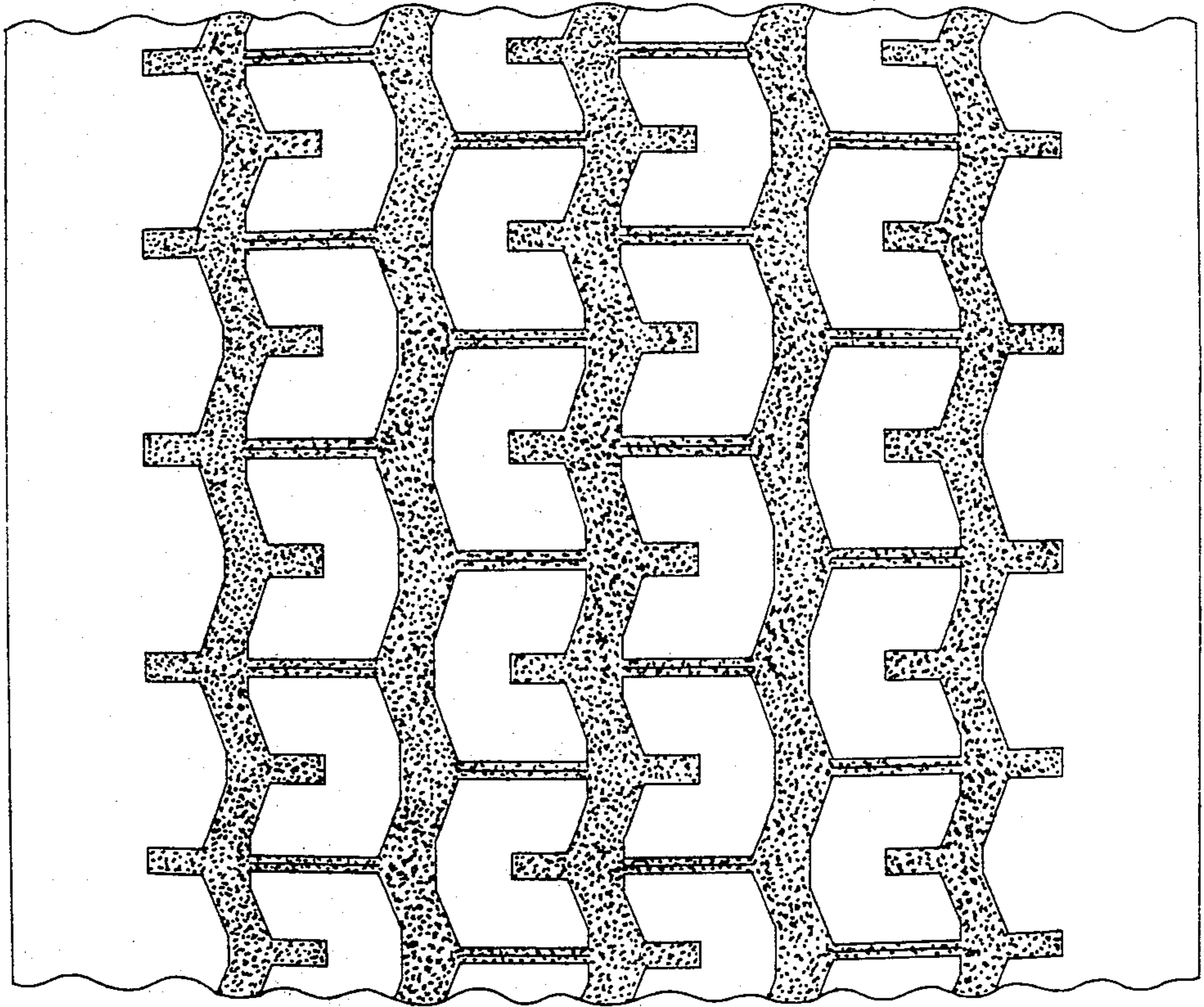

FIG. 3