

[54] BOAT

[75] Inventor: Arthur E. Carlson, Huntington Beach, Calif.

[73] Assignee: Bangor Punta Corporation, Greenwich, Conn.

[**] Term: 14 Years

[21] Appl. No.: 504,098

[22] Filed: Jun. 13, 1983

[52] U.S. Cl. D12/312

[58] Field of Search D12/300, 304, 310, 318, D12/311, 312; 114/61

[56] References Cited

U.S. PATENT DOCUMENTS

| | | | | |
|------------|---------|----------|-------|---------|
| D. 210,118 | 11/1970 | Baker | | D12/300 |
| D. 222,510 | 10/1971 | Centaro | | D12/300 |
| D. 224,363 | 7/1972 | Davidson | | D12/300 |
| D. 243,445 | 2/1977 | Khoury | | D12/300 |
| D. 244,841 | 6/1977 | Nescher | | D12/312 |

| | | | | |
|------------|--------|---------|-------|---------|
| D. 267,866 | 2/1983 | Parsons | | D12/311 |
| 4,348,972 | 9/1982 | Parsons | | D12/312 |

OTHER PUBLICATIONS

1981 Checkmate Speedboat Catalogue-1981 Boat Show Box.

Primary Examiner—Wallace R. Burke
Assistant Examiner—Brian N. Vinson
Attorney, Agent, or Firm—Patrick J. Walsh

[57] CLAIM

The ornamental design for a boat, as shown.

DESCRIPTION

FIG. 1 is a perspective view of a boat showing my new design;
FIG. 2 is a front elevation thereof;
FIG. 3 is a rear elevation thereof;
FIG. 4 is a side elevation thereof;
FIG. 5 is a top plan thereof;
FIG. 6 is a perspective view showing the boat hull bottom.

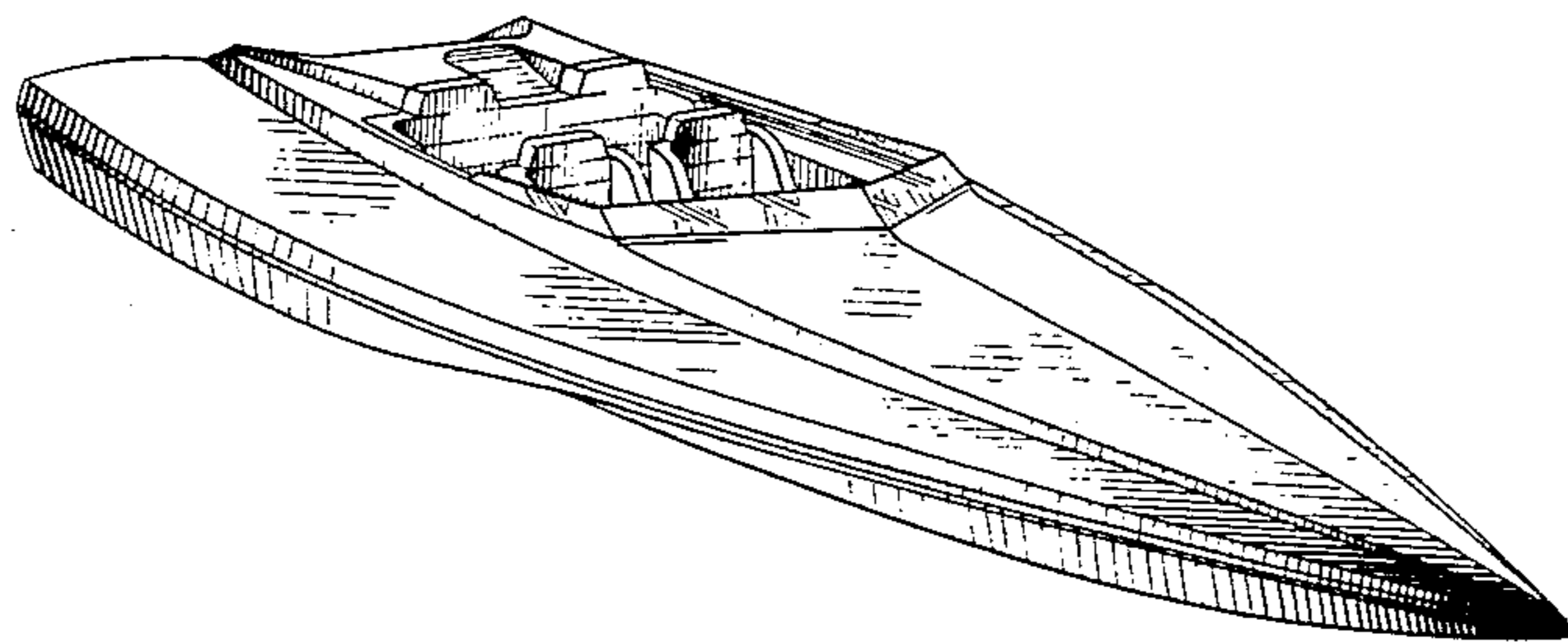

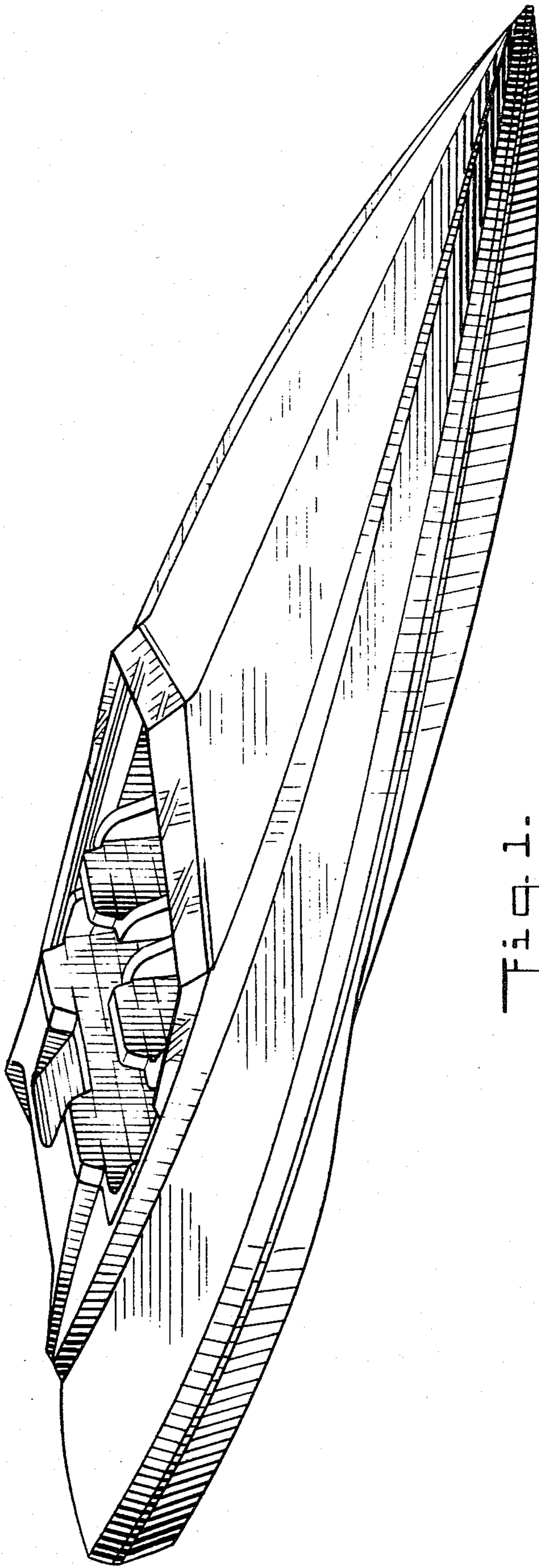

Fig. 1.

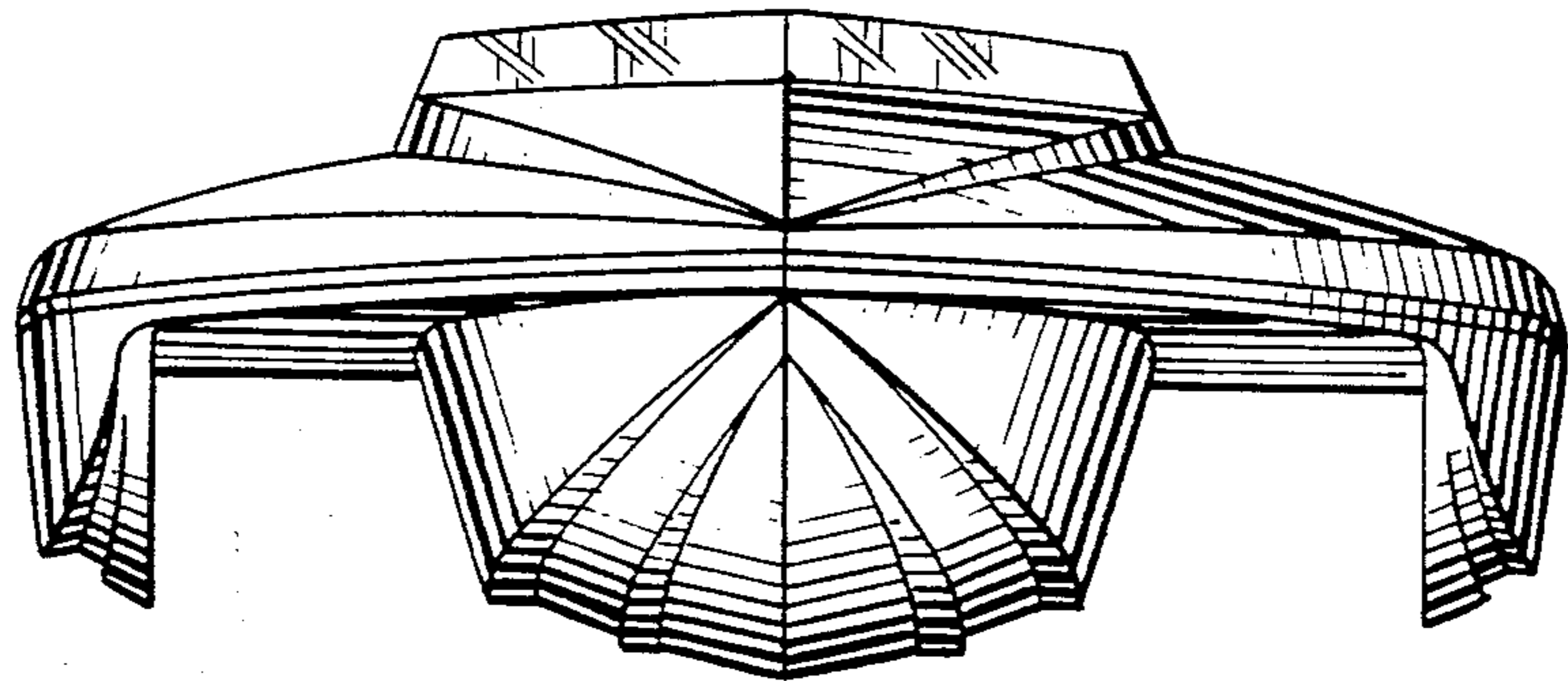

Fig. 2.

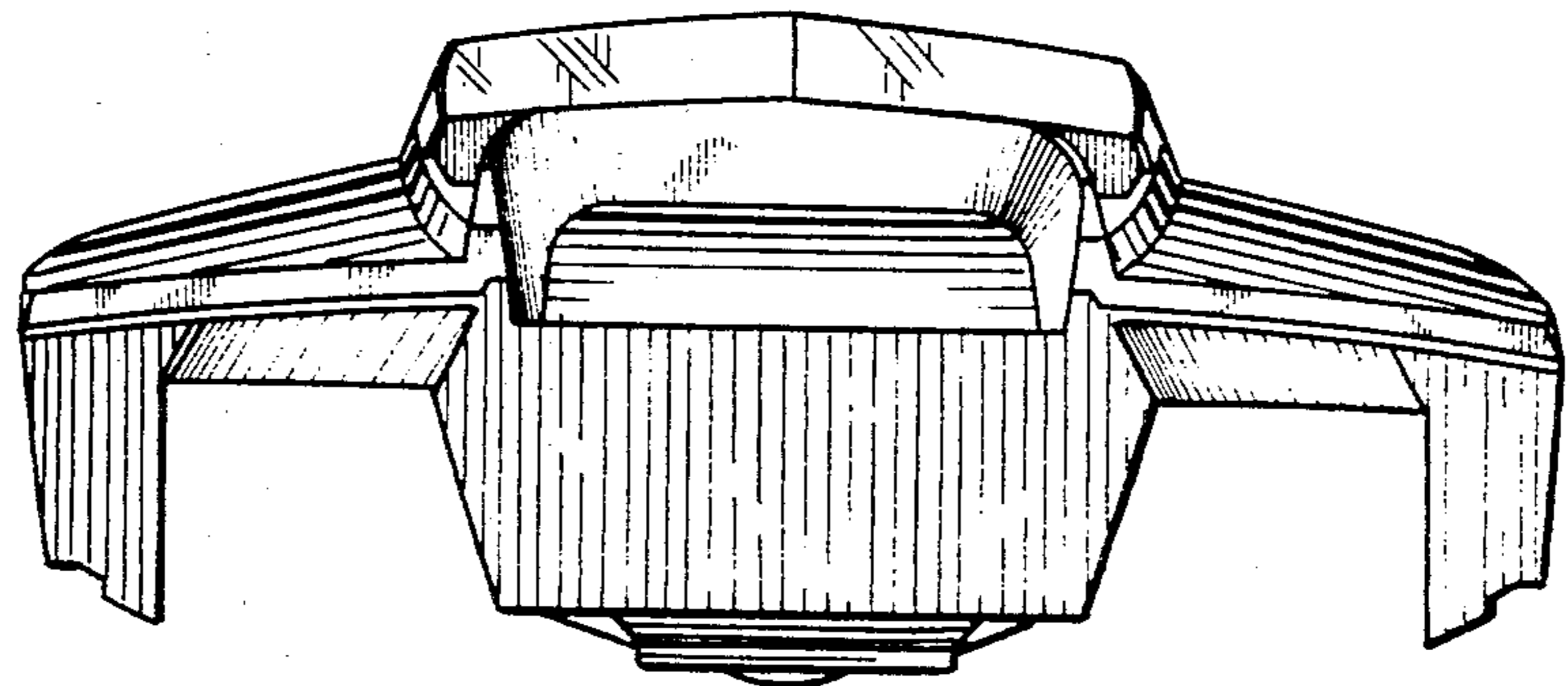

Fig. 3.

Fig. 4.

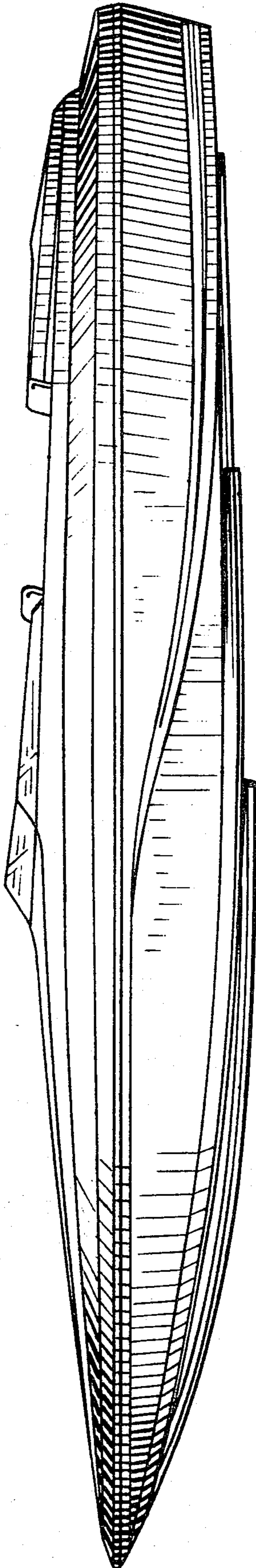
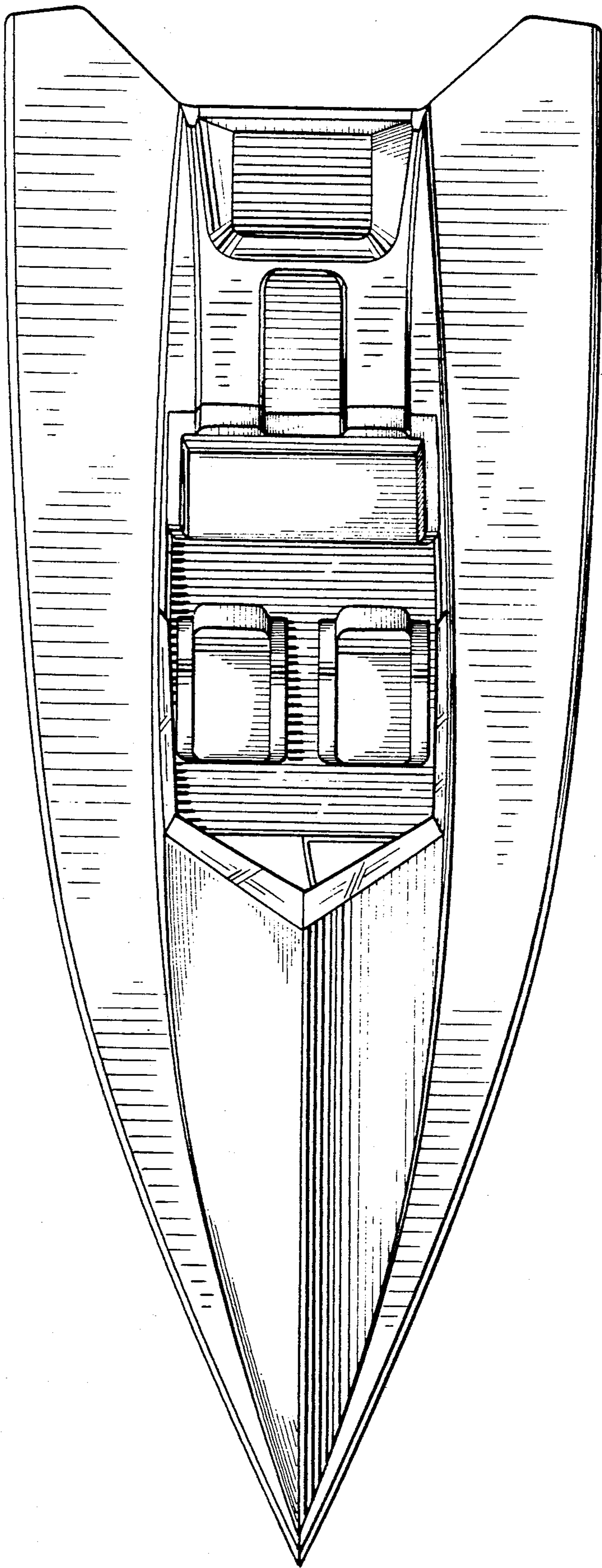

Fig. 5.



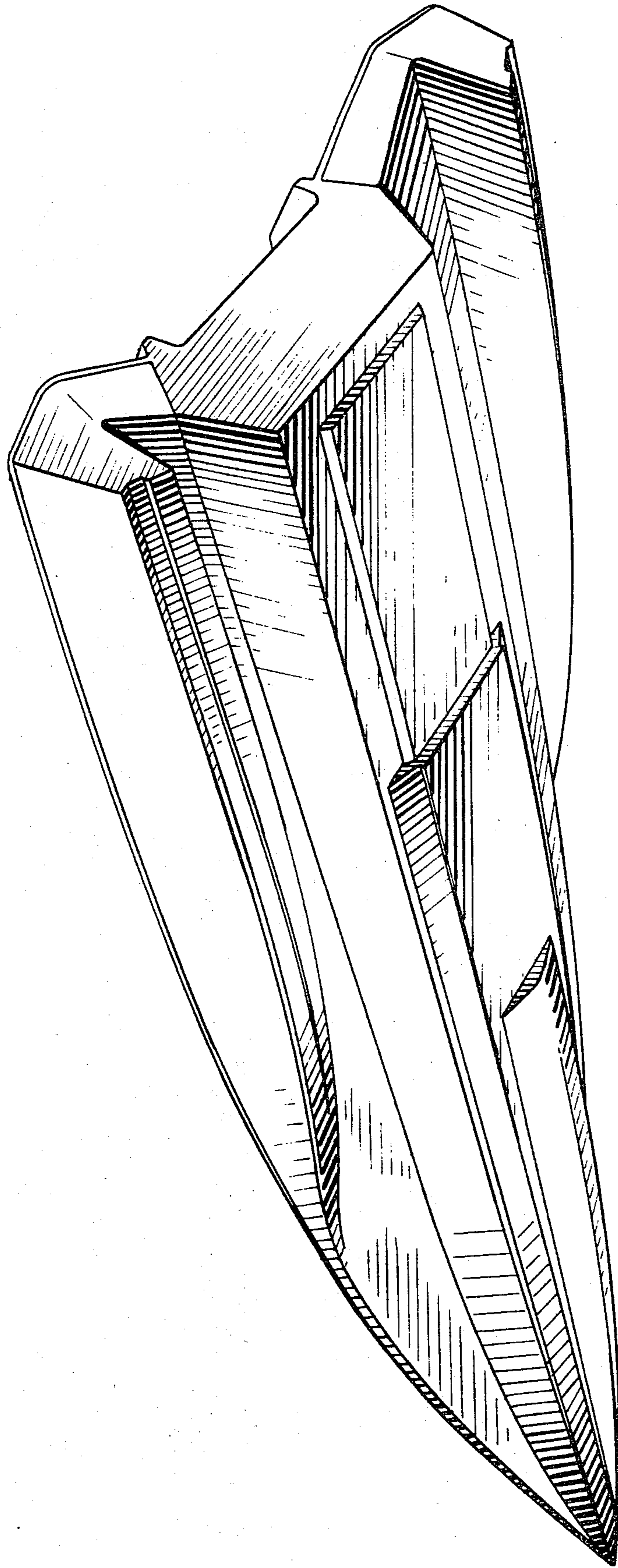

Fig. 6.