

[54] PAIR OF MOTORCYCLE DRIVER'S FLOORBOARDS

[75] Inventors: James M. Preisler, Mound; Alwin J. Stahel, St. Paul; Carl R. Van Horn, Thief River Falls, all of Minn.

[73] Assignee: Drag Specialties, Inc., Minnetonka, Minn.

[**] Term: 14 Years

[21] Appl. No.: 478,419

[22] Filed: Mar. 23, 1983

[52] U.S. Cl. D12/114

[58] Field of Search D12/114, 174; 280/289 R, 291; 74/564; 180/219

[56] References Cited

U.S. PATENT DOCUMENTS

- D. 270,527 9/1983 O'Rourke D12/114
- D. 270,823 10/1983 Mounts D12/114

OTHER PUBLICATIONS

BMS Form #001, "Custom Floor Boards for Honda GL 1000's and 1100's," BMS Manufacturing, Rock Island, Illinois, undated (available prior to 5/9/83).
 Spring 1982 Catalog of Drag Specialties, Inc., "Driver & Passenger Floorboards," p. 6, item A&B, Part. No. 720230 & 720231.

Primary Examiner—James M. Gandy
 Attorney, Agent, or Firm—Faegre & Benson

[57] CLAIM

The ornamental design for a pair of motorcycle driver's floorboards, as shown and described.

DESCRIPTION

FIG. 1 is a top plan view of a pair of motorcycle driver's floorboards embodying our new design in position of use, it being understood that the broken lines are for illustration purposes only;
 FIG. 2 is an enlarged top plan view of the left-hand driver's floorboard thereof;
 FIG. 3 is an enlarged bottom plan view of the left-hand driver's floorboard thereof;
 FIG. 4 is an enlarged left side elevational view of the left-hand driver's floorboard thereof;
 FIG. 5 is an enlarged right side elevational view of the left-hand driver's floorboard thereof;
 FIG. 6 is an enlarged front elevational view of the left-hand driver's floorboard thereof;
 FIG. 7 is an enlarged rear elevational view of the left-hand driver's floorboard thereof;
 FIG. 8 is an enlarged top plan view of the right-hand driver's floorboard thereof;
 FIG. 9 is an enlarged bottom plan view of the right-hand driver's floorboard thereof;
 FIG. 10 is an enlarged right side elevational view of the right-hand driver's floorboard thereof;
 FIG. 11 is an enlarged left side elevational view of the right-hand driver's floorboard thereof;
 FIG. 12 is an enlarged front elevational view of the right-hand driver's floorboard thereof;
 FIG. 13 is an enlarged rear elevational view of the right-hand driver's floorboard thereof.

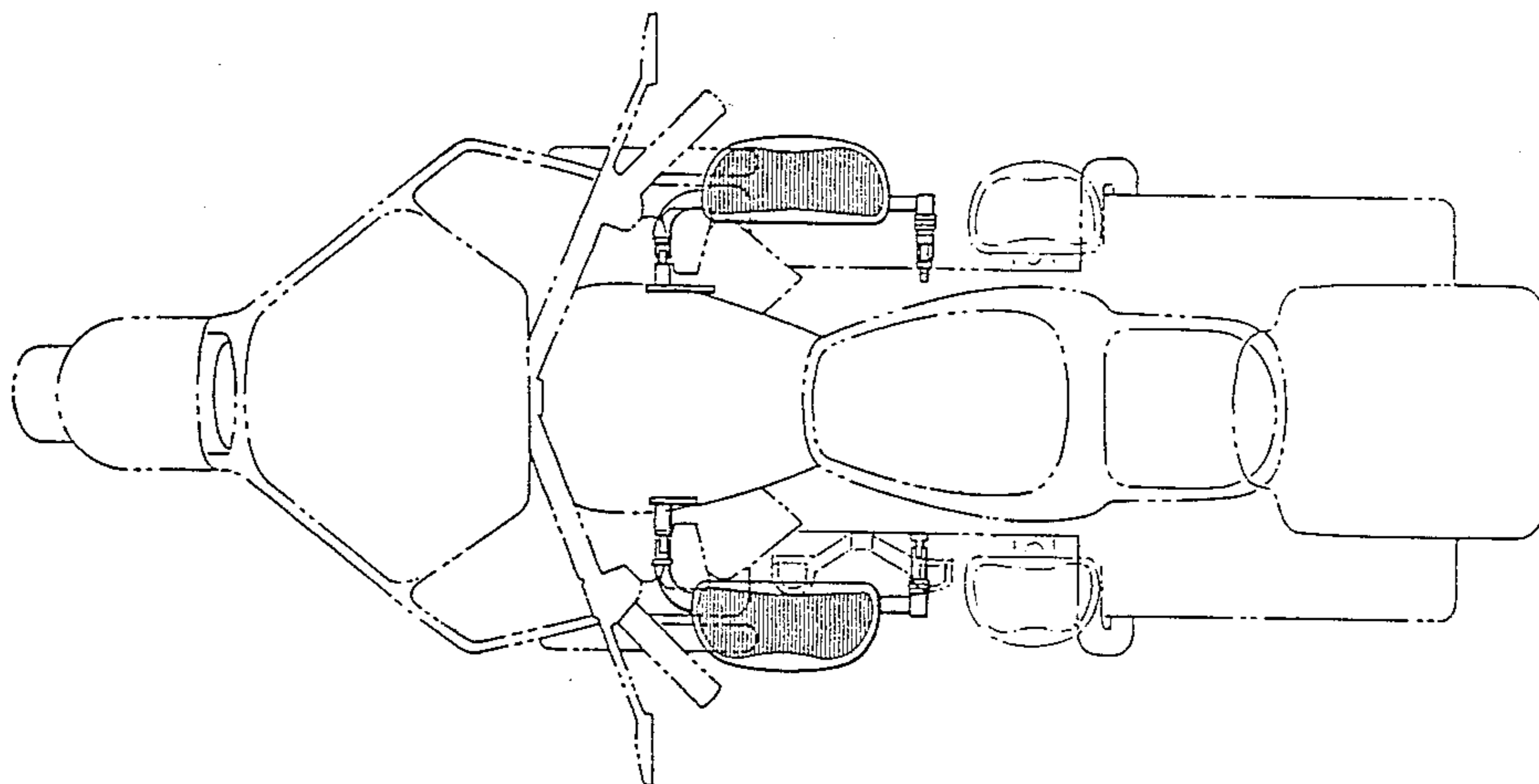

Fig. 1

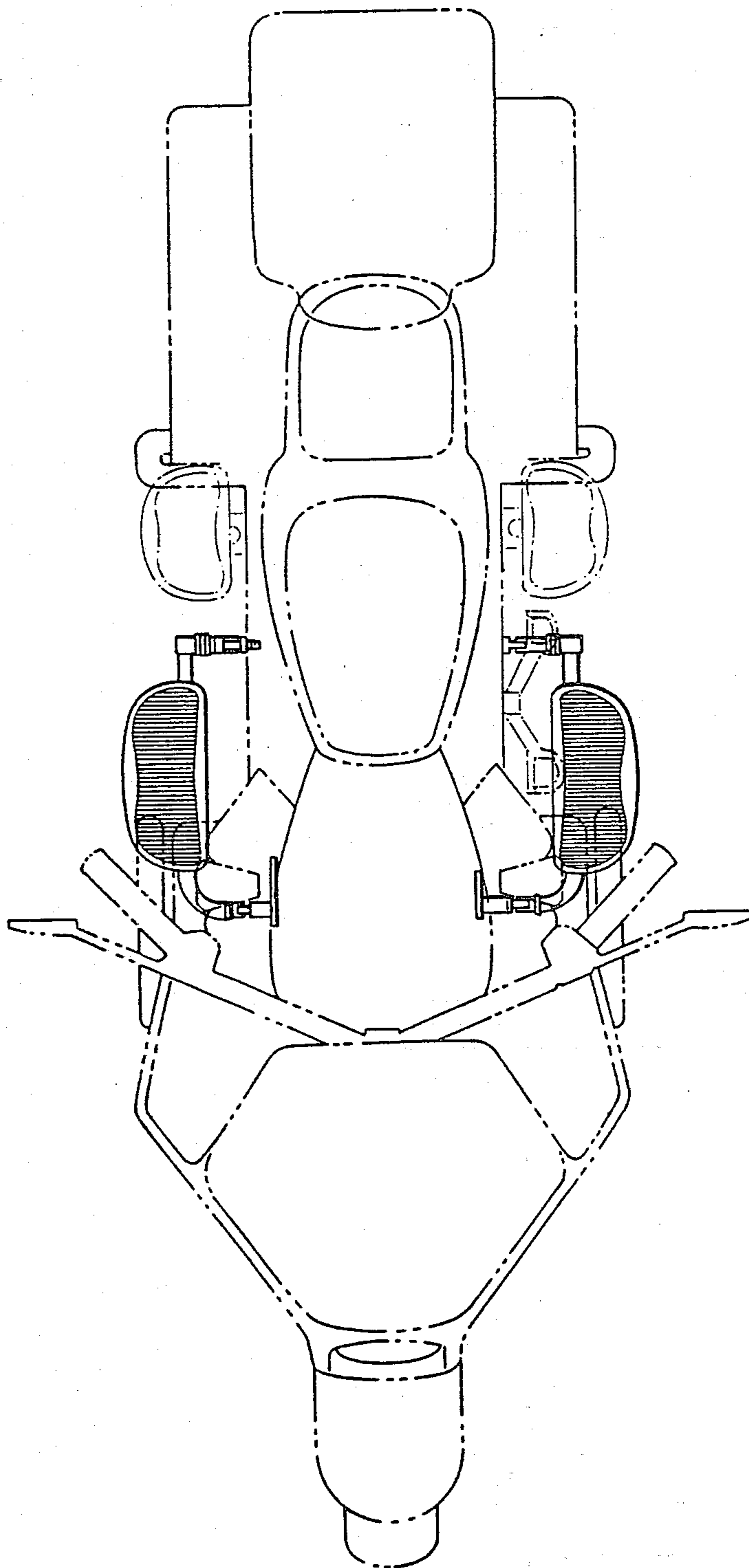

Fig. 2

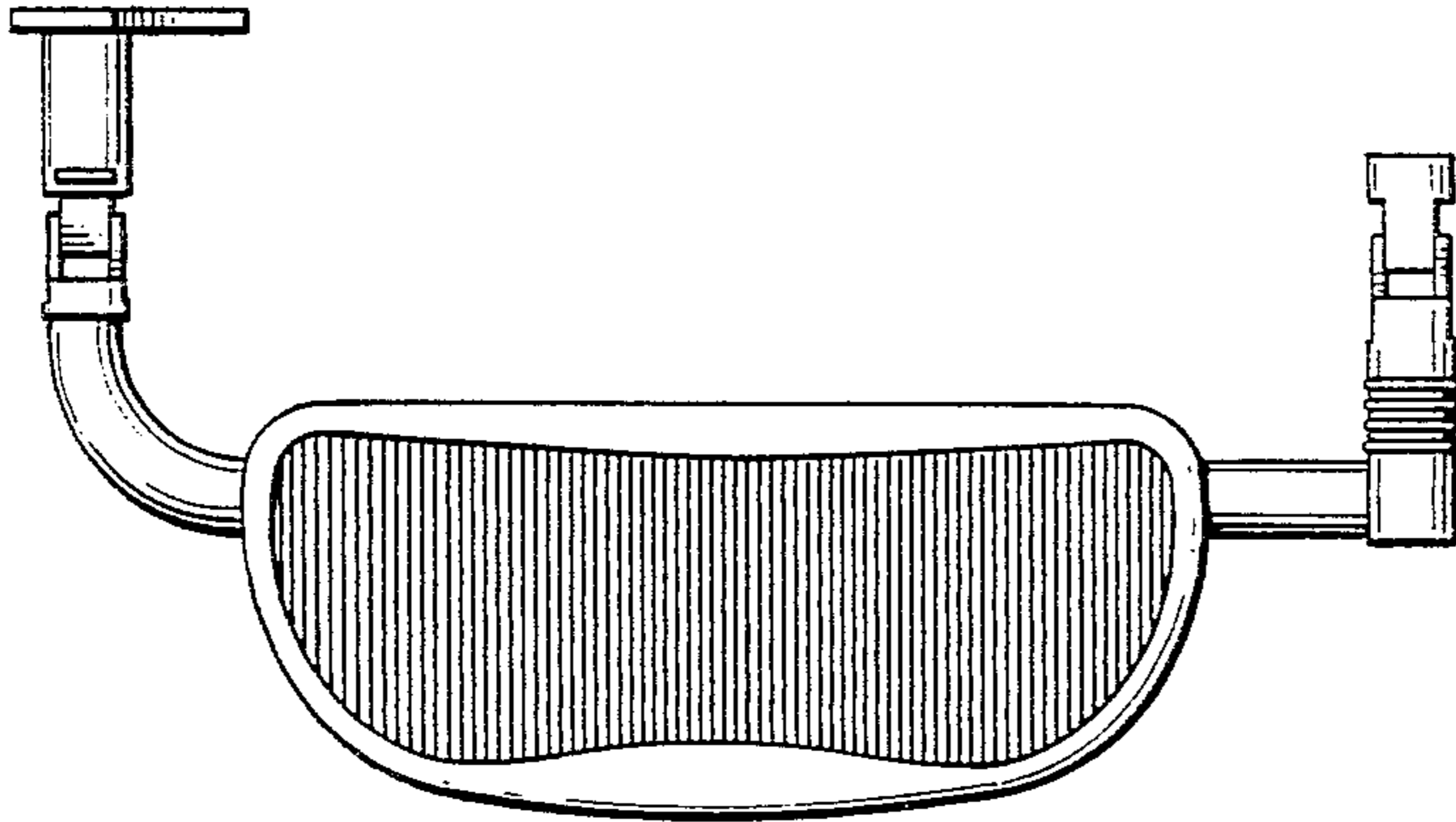

Fig. 3

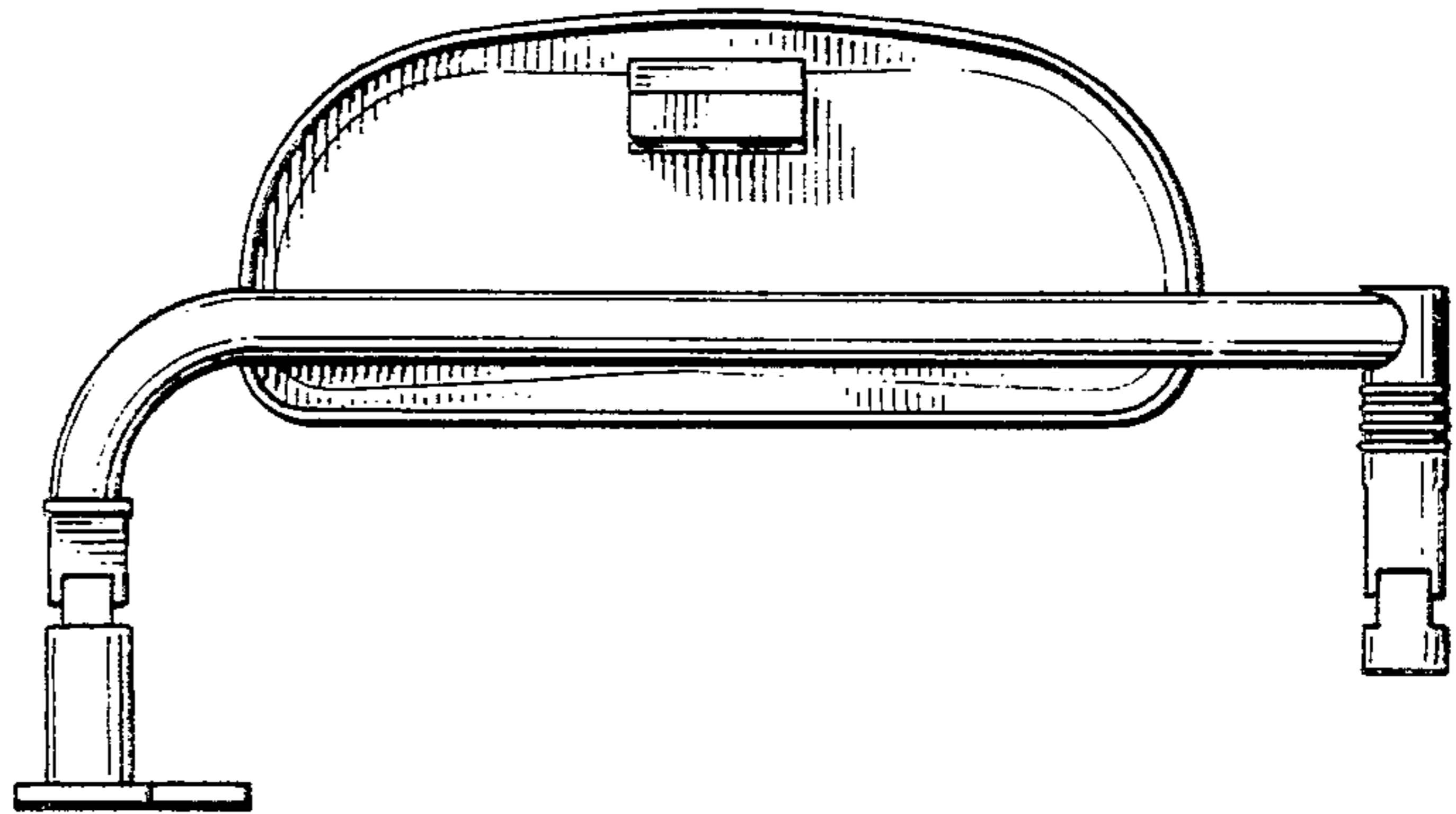

Fig. 4

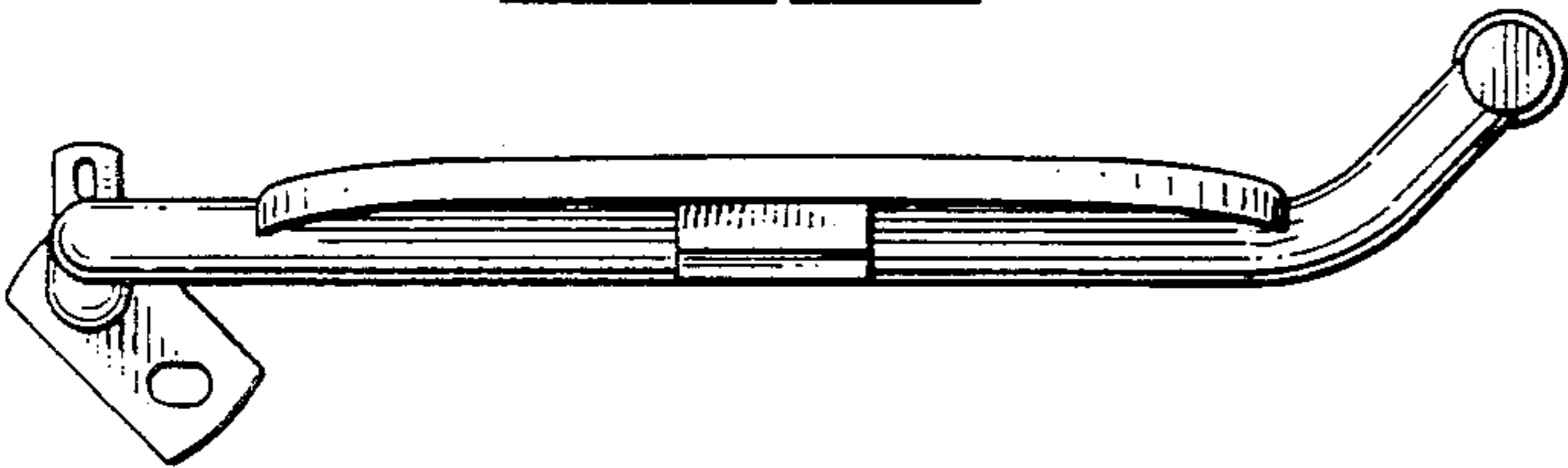

Fig. 5



Fig. 6

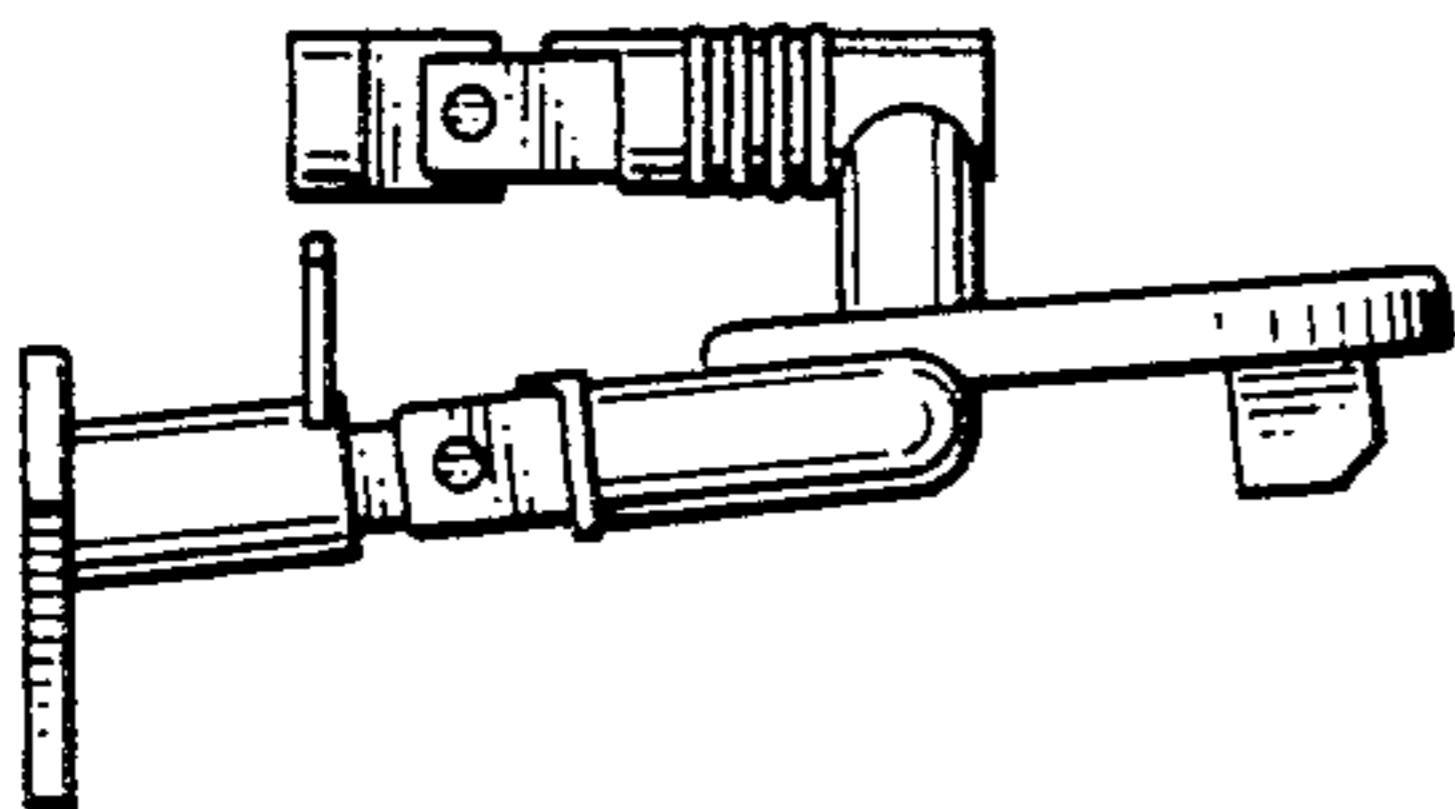

Fig. 7

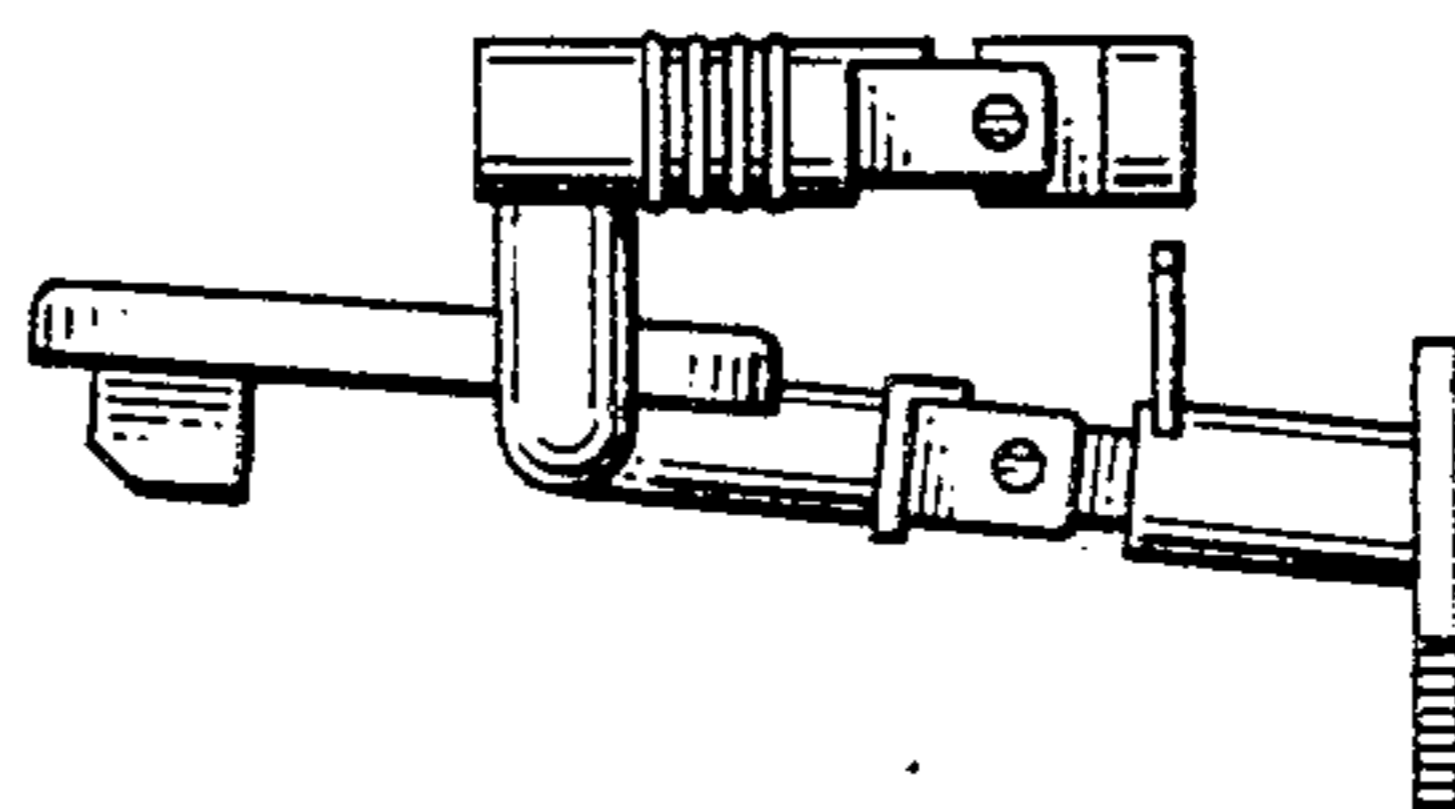

Fig. 8

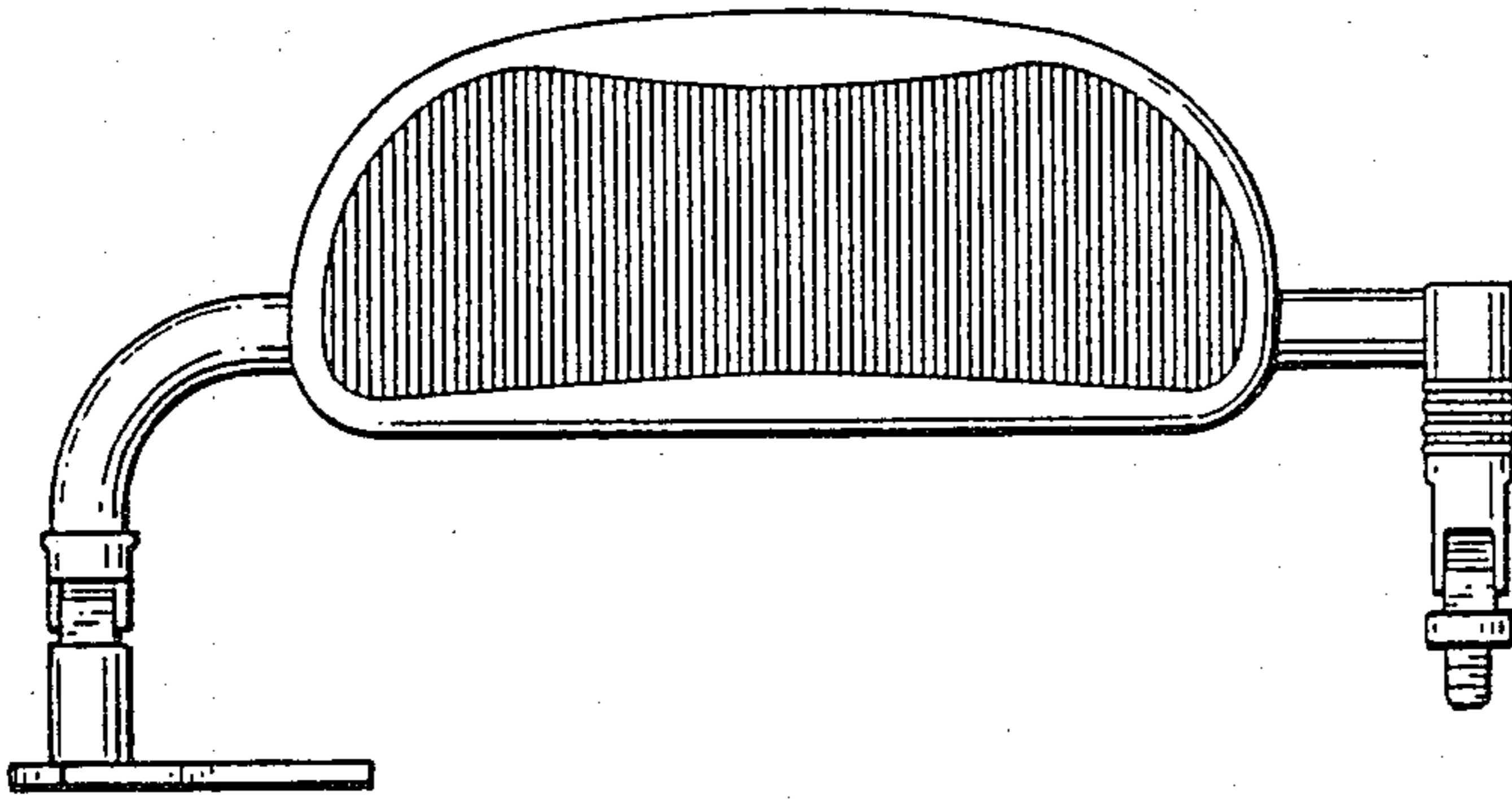

Fig. 9

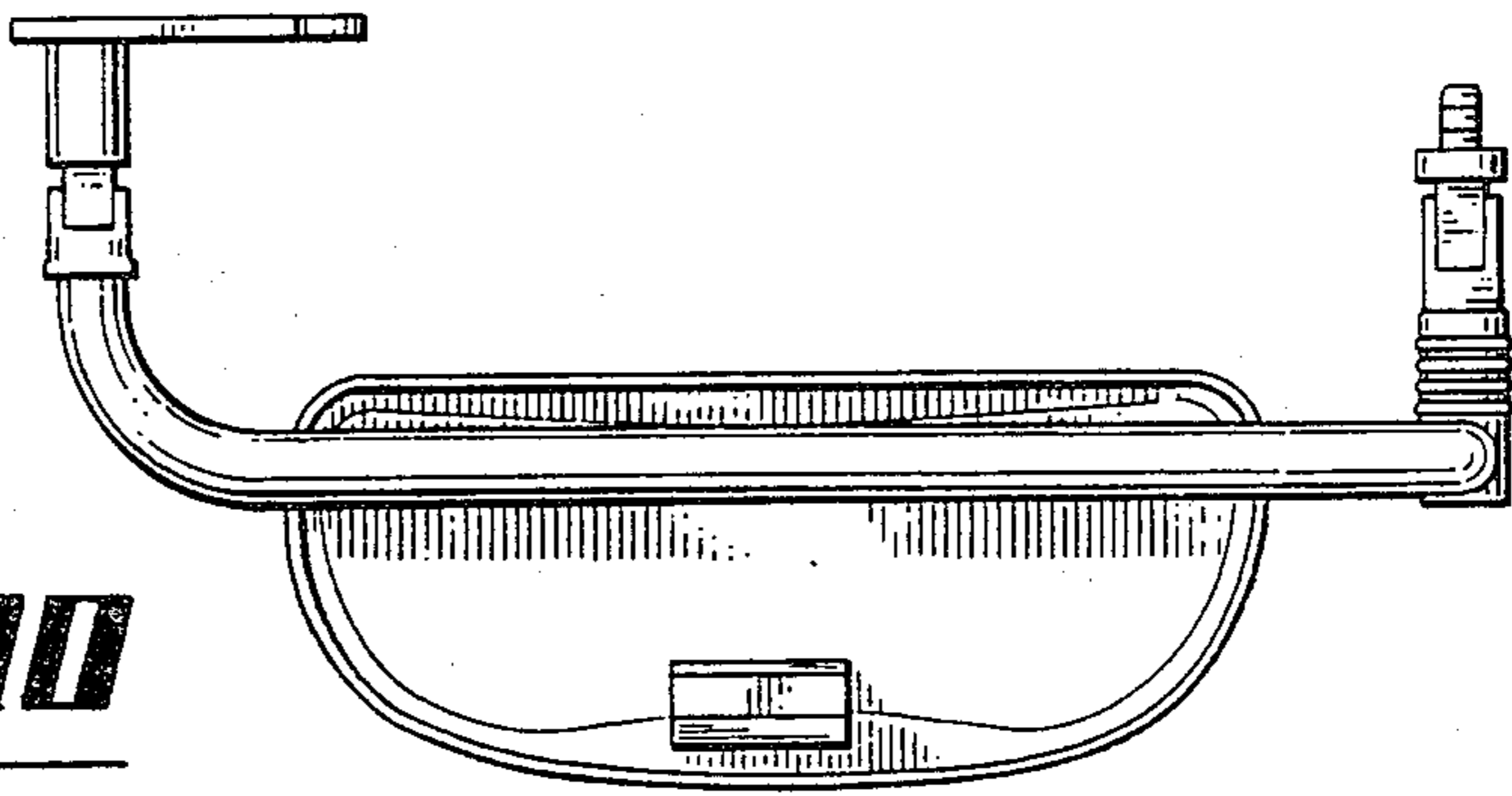

Fig. 10

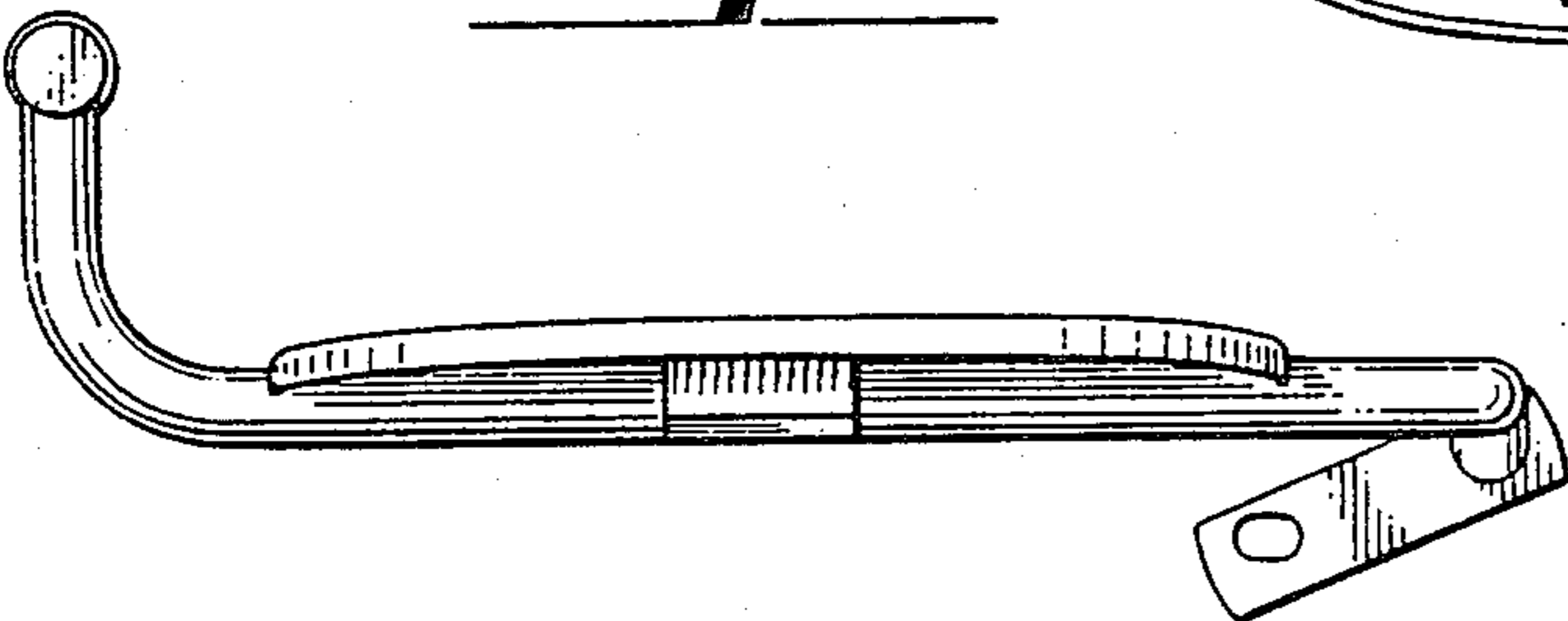

Fig. 11

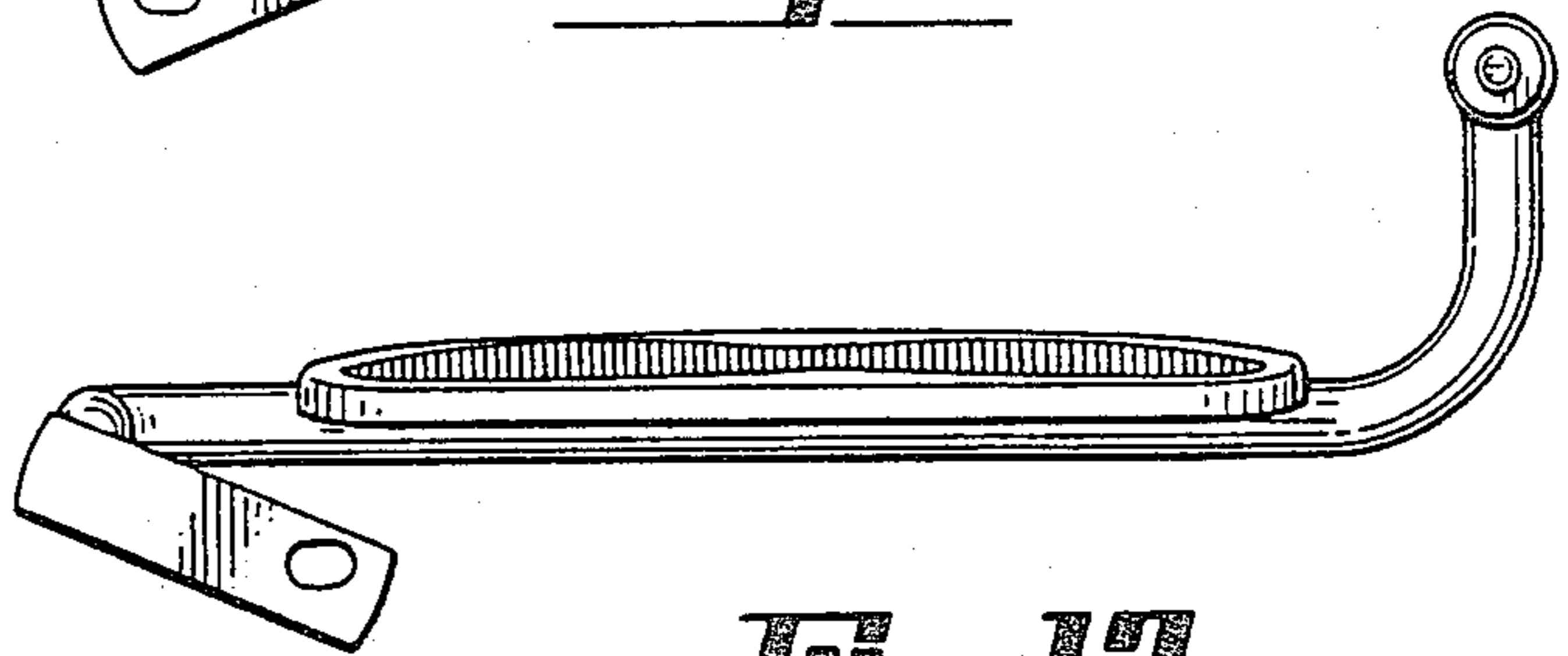

Fig. 13

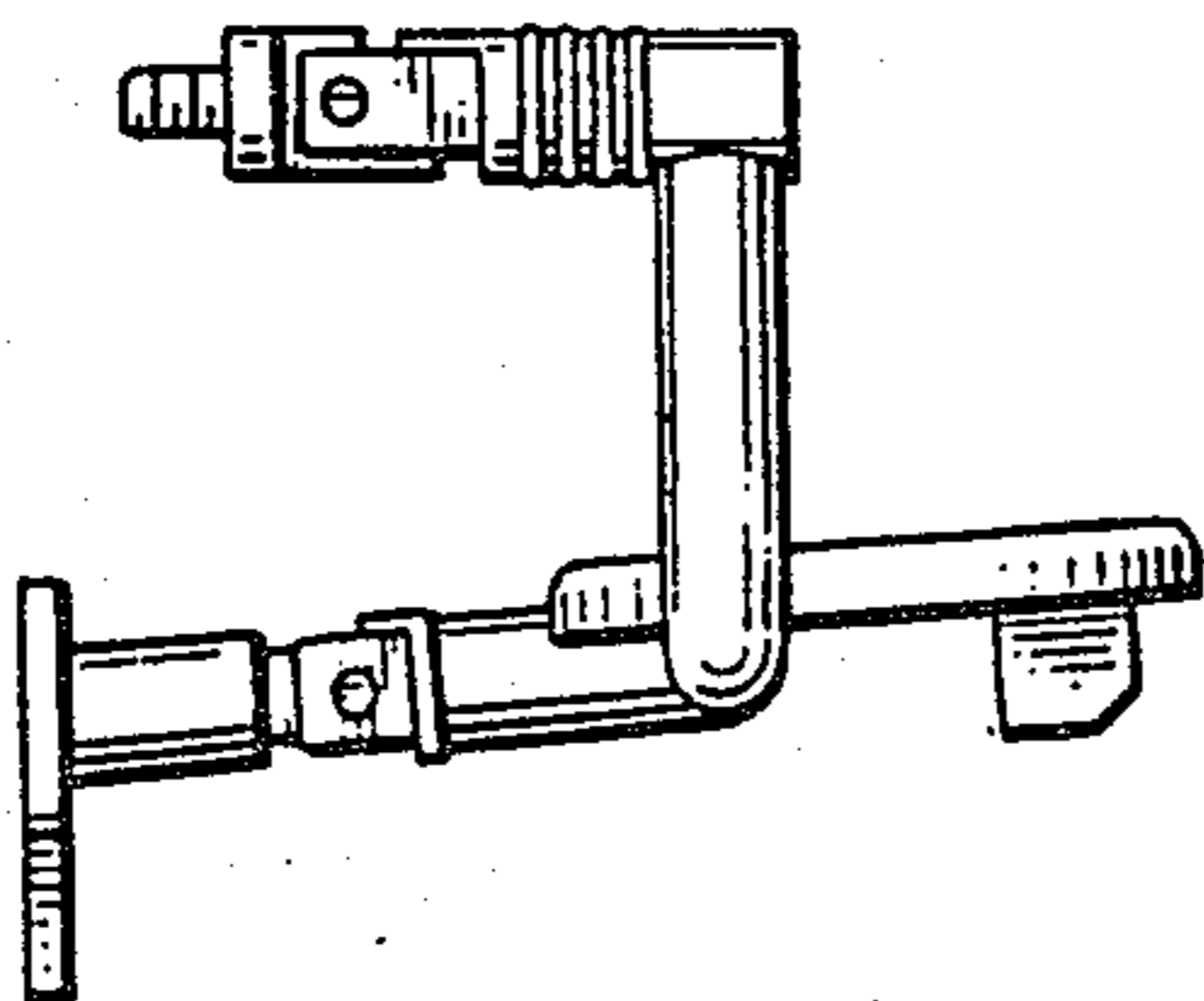

Fig. 12

