

[54] **COMBINED ELECTRIC TOOTHBRUSH  
HOLDER AND STAND**

[56] **References Cited**

**U.S. PATENT DOCUMENTS**

[75] **Inventor: Ng Cheuk-Yiu, Hong Kong, Hong  
Kong**

D. 221,823 9/1971 Cook ..... D4/101  
D. 266,117 9/1982 Oberheim ..... D4/101

[73] **Assignee: Blue Box Toy Factory Limited,  
Kowloon, Hong Kong**

*Primary Examiner*—Catherine E. Kemper  
*Attorney, Agent, or Firm*—Pollock, Vande Sande &  
Priddy

[\*\*] **Term: 14 Years**

[57] **CLAIM**

[21] **Appl. No.: 530,914**

The ornamental design for a combined electric tooth-  
brush holder and stand, as shown.

[22] **Filed: Sep. 9, 1983**

**DESCRIPTION**

[30] **Foreign Application Priority Data**

May 9, 1983 [GB] United Kingdom ..... 1 012 917

[52] **U.S. Cl. .... D4/101**

FIG. 1 is a top front perspective view of a combined  
electric toothbrush holder and stand, showing my new  
design;

FIG. 2 is a right end elevational view thereof;

FIG. 3 is a rear elevational view thereof;

[58] **Field of Search ..... D4/101; 15/22 R, 23,  
15/24; 128/66**

FIG. 4 is a perspective view of the device with the  
toothbrush removed from the stand.

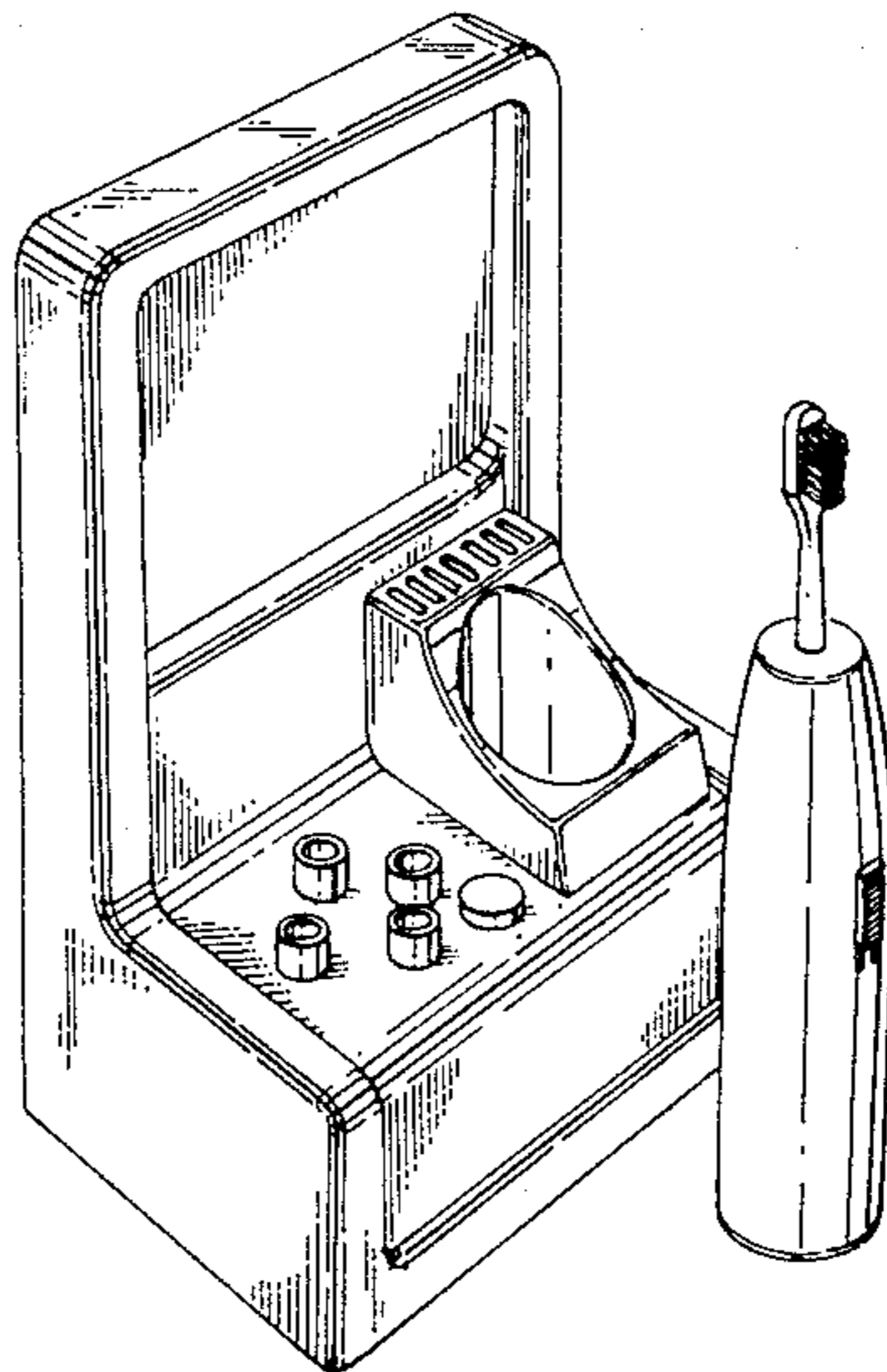

FIG. 1.

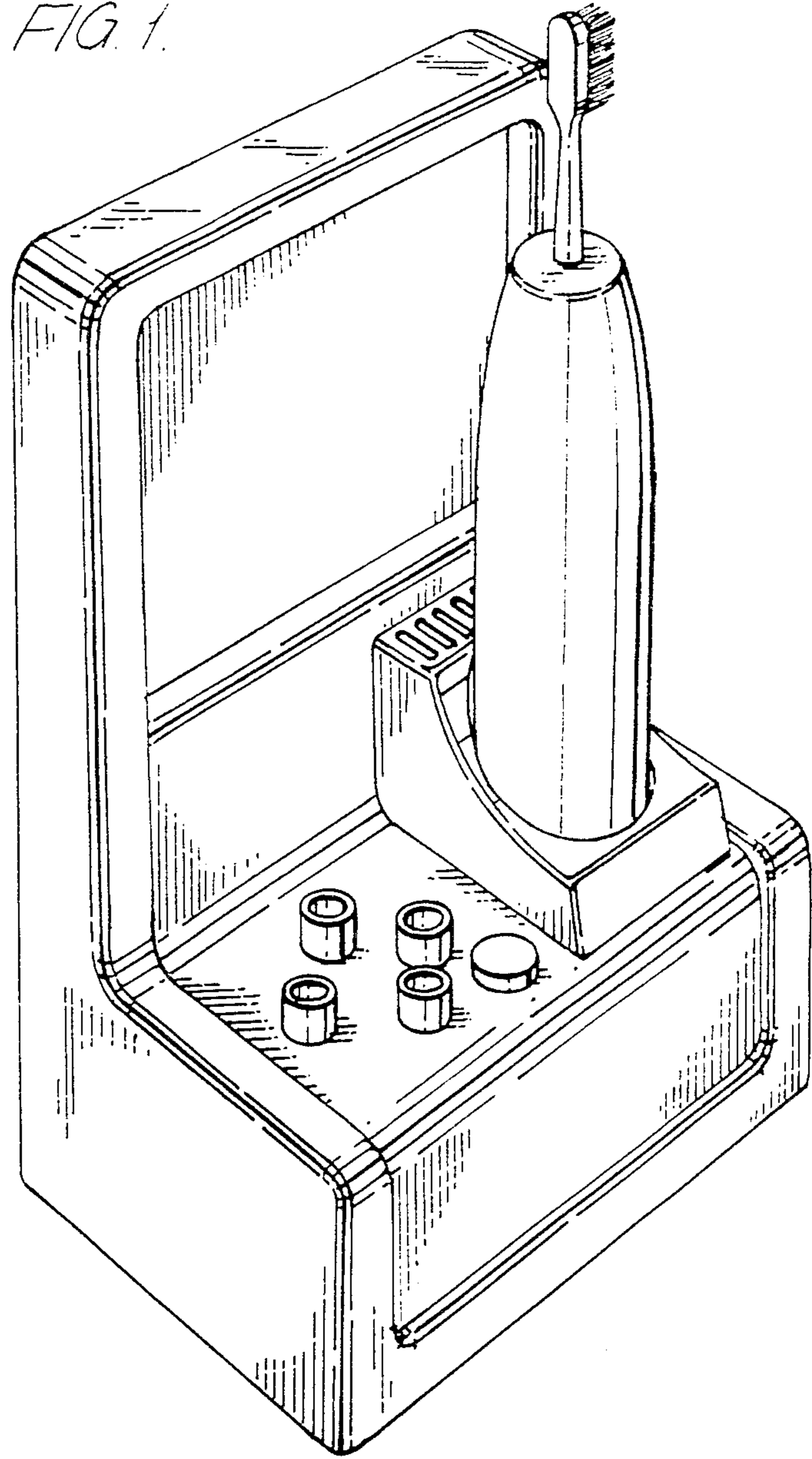

FIG. 2.

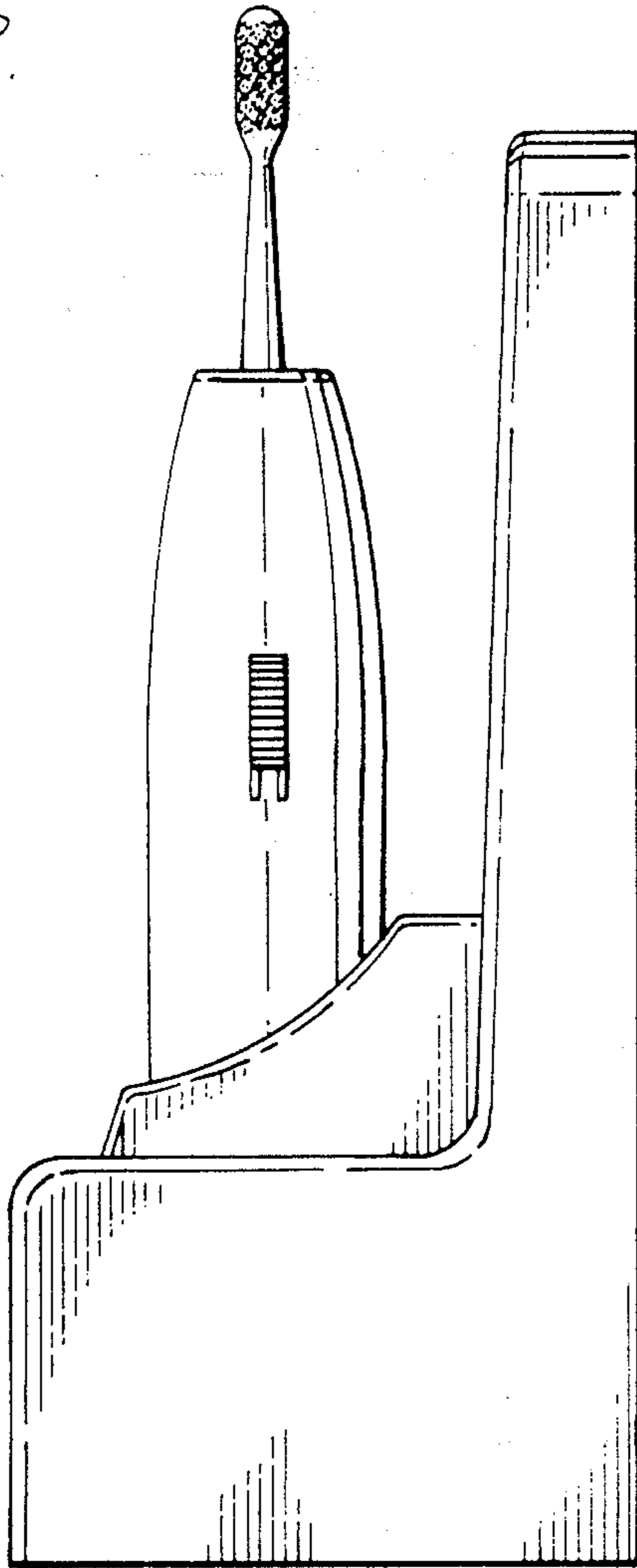

FIG. 3.

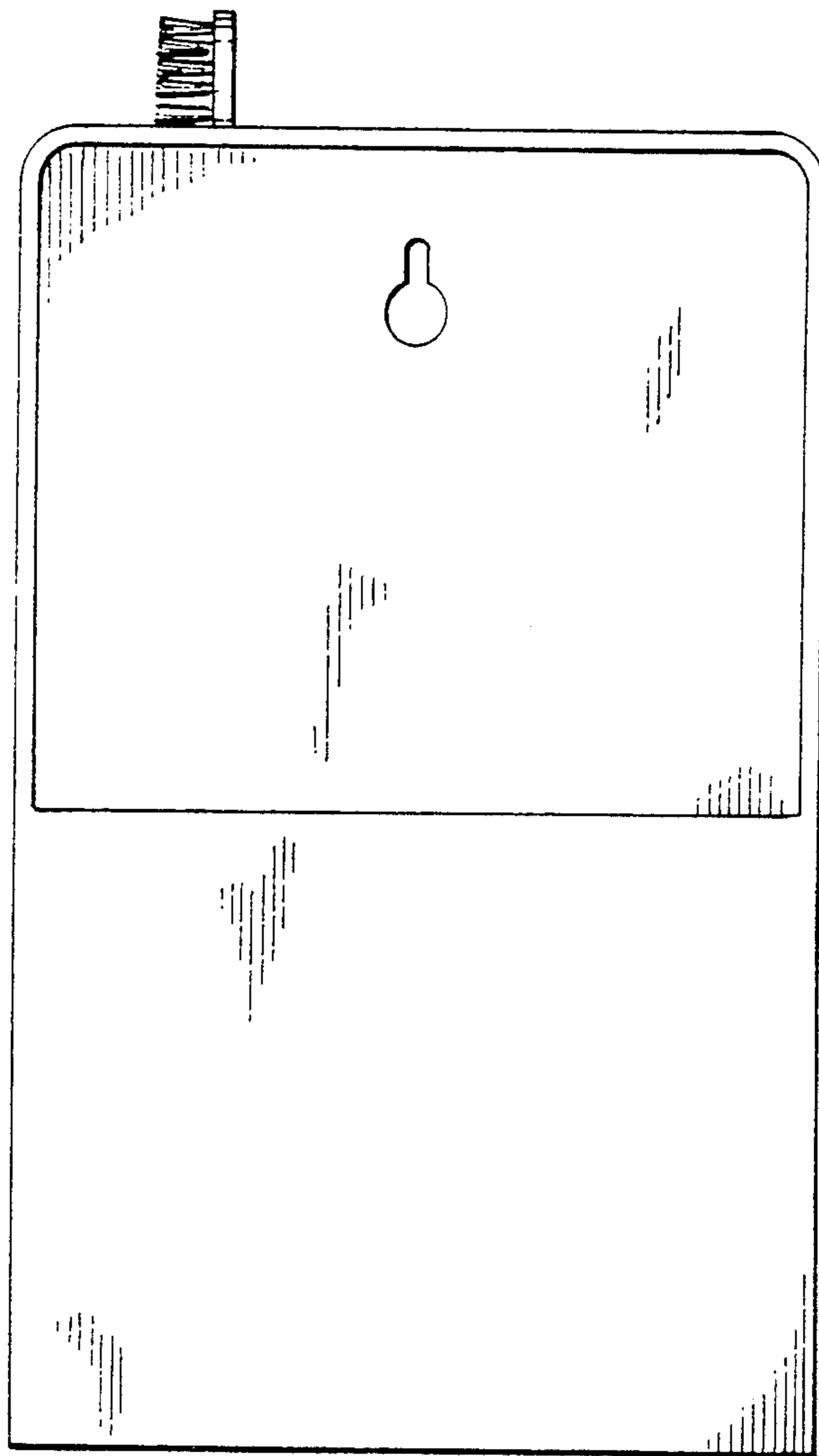

FIG. 4.

