

[54] **BLADE FOR A MACHINE FOR ADJUSTING THE POSITION OF RAILWAY TRACKS**

[76] Inventors: **Arne Johansson**, Slattervagen 11, S-691 36 Karlskoga; **Torsten Larsson**, Hogerkroken 7, S-382 00 Nybro, both of Sweden

[**] Term: **14 Years**

[21] Appl. No.: **527,468**

[22] Filed: **Aug. 29, 1983**

[30] **Foreign Application Priority Data**

Mar. 1, 1983 [SE] Sweden 83-574
[52] U.S. Cl. **D15/28**
[58] Field of Search D15/28; 104/10, 11, 104/12, 13, 14

[56] **References Cited**

U.S. PATENT DOCUMENTS

3,581,664 6/1971 Kruse 104/10

3,677,187	7/1972	Stewart	104/10
3,729,055	4/1973	Burridge	104/10
4,062,291	12/1977	Vick et al.	104/10
4,068,594	1/1978	Crowell	104/10
4,160,419	7/1979	Stewart	104/10
4,218,978	8/1980	Pasquini	104/10

Primary Examiner—B. J. Bullock
Assistant Examiner—Suzanne N. Gitlin
Attorney, Agent, or Firm—Pollock, Vande Sande & Priddy

[57] **CLAIM**

The ornamental design for a blade for a machine for adjusting the position of railway tracks or a similar article, substantially as shown and described.

DESCRIPTION

FIG. 1 is an oblique top, front perspective view of a blade for a machine for adjusting the position of railway tracks showing our new design; FIG. 2 is an oblique top, rear perspective view thereof; FIG. 3 is an oblique bottom, rear perspective view thereof.

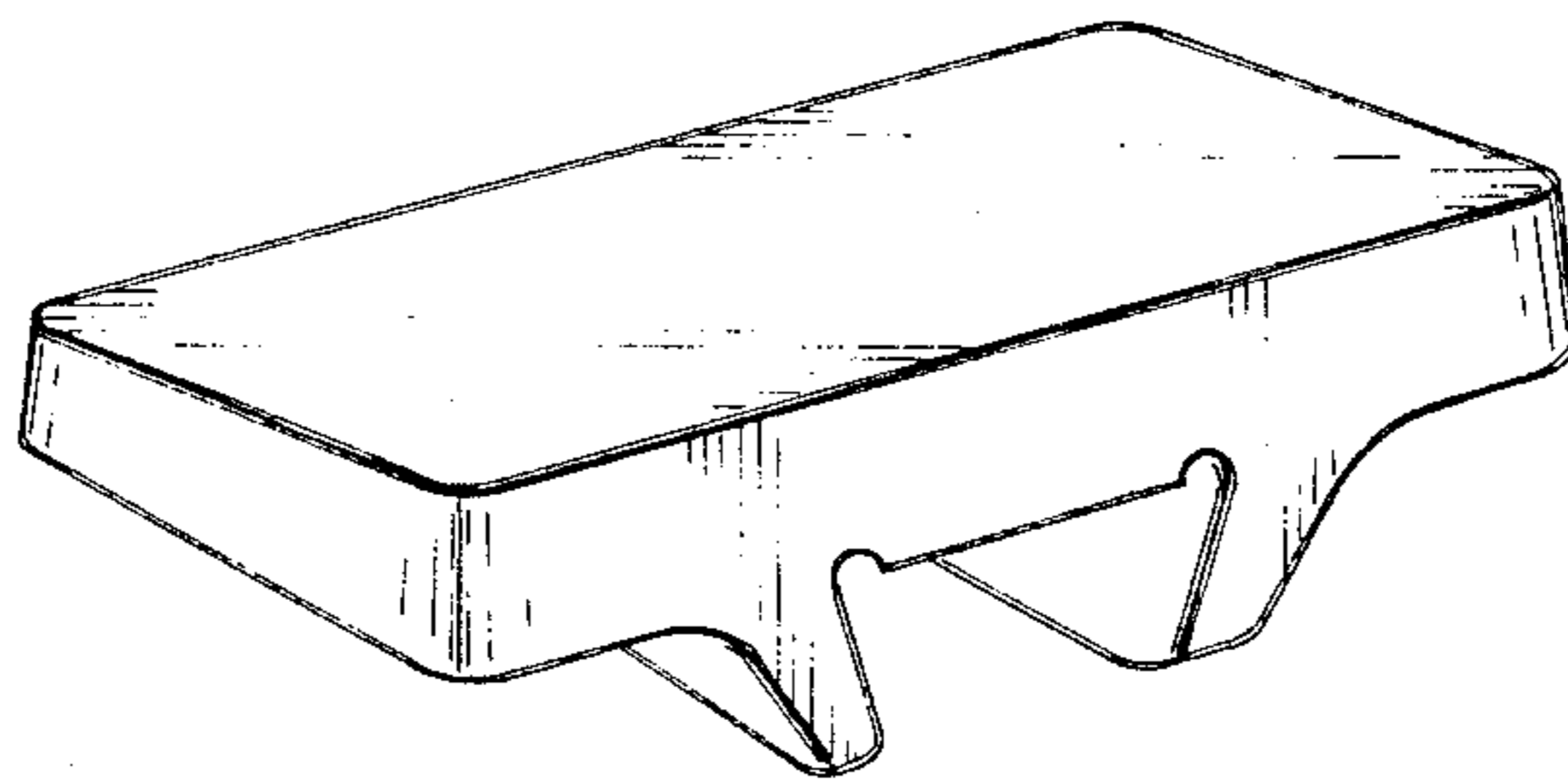
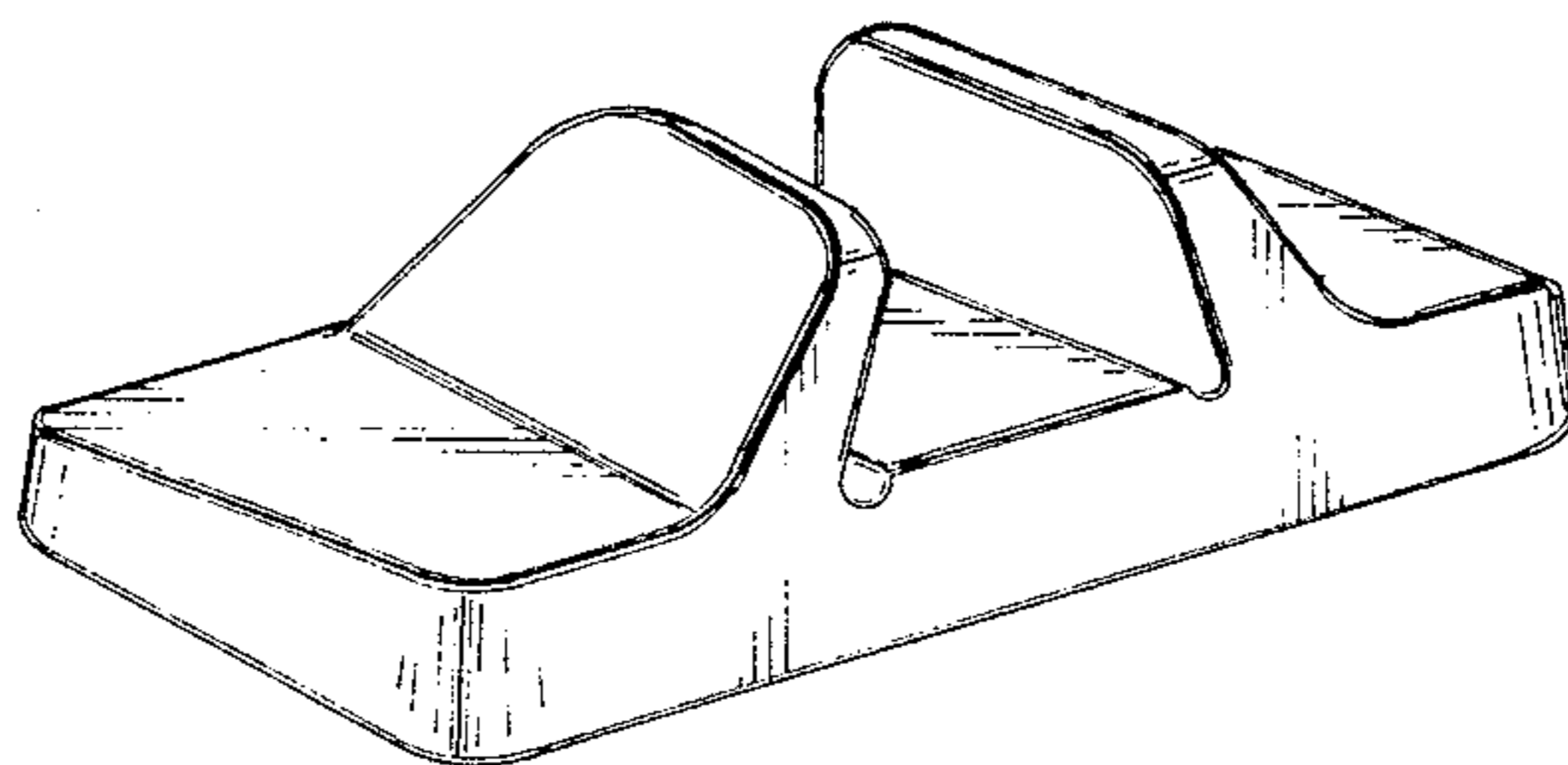

FIG 1

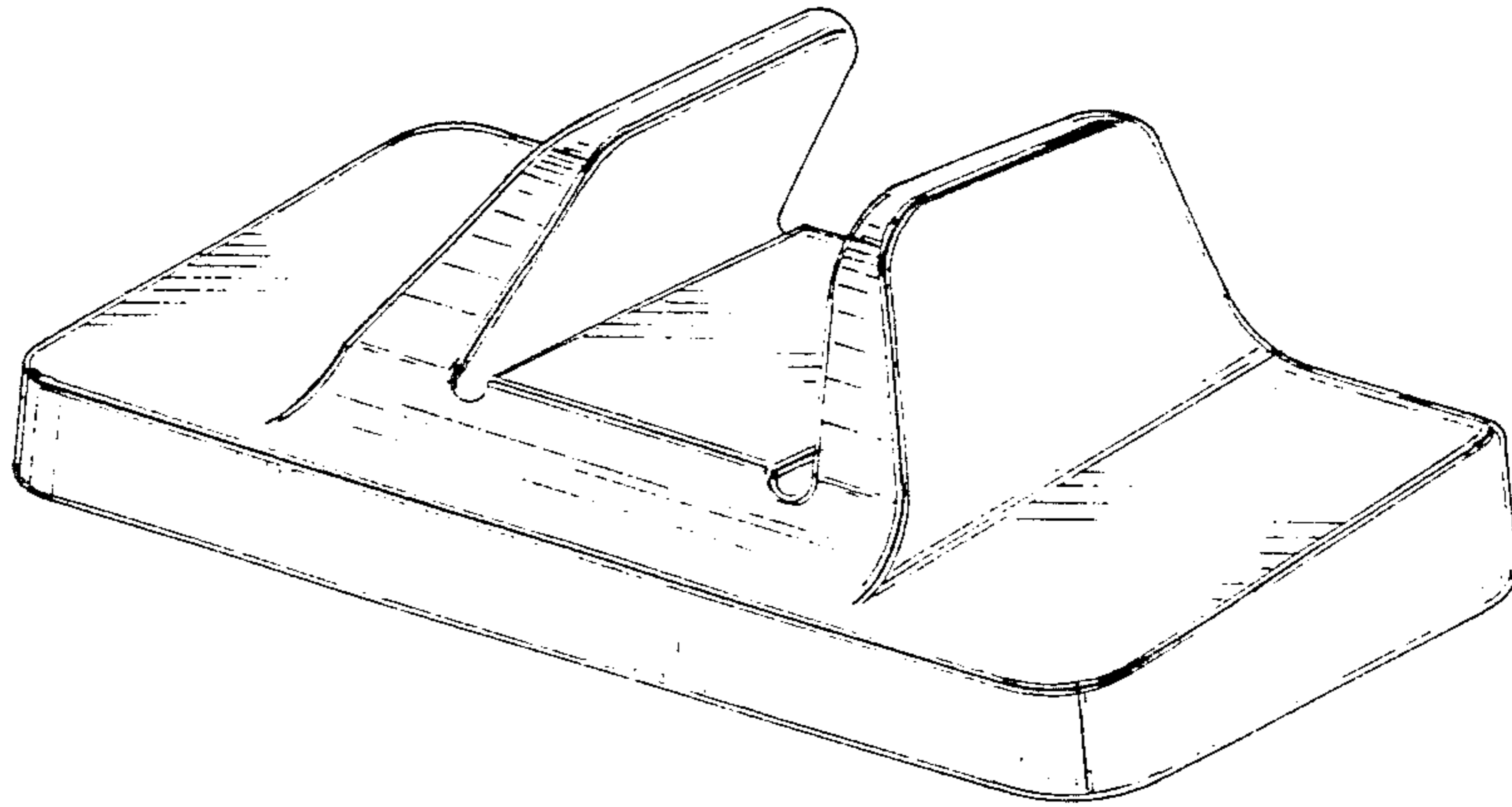

FIG 2

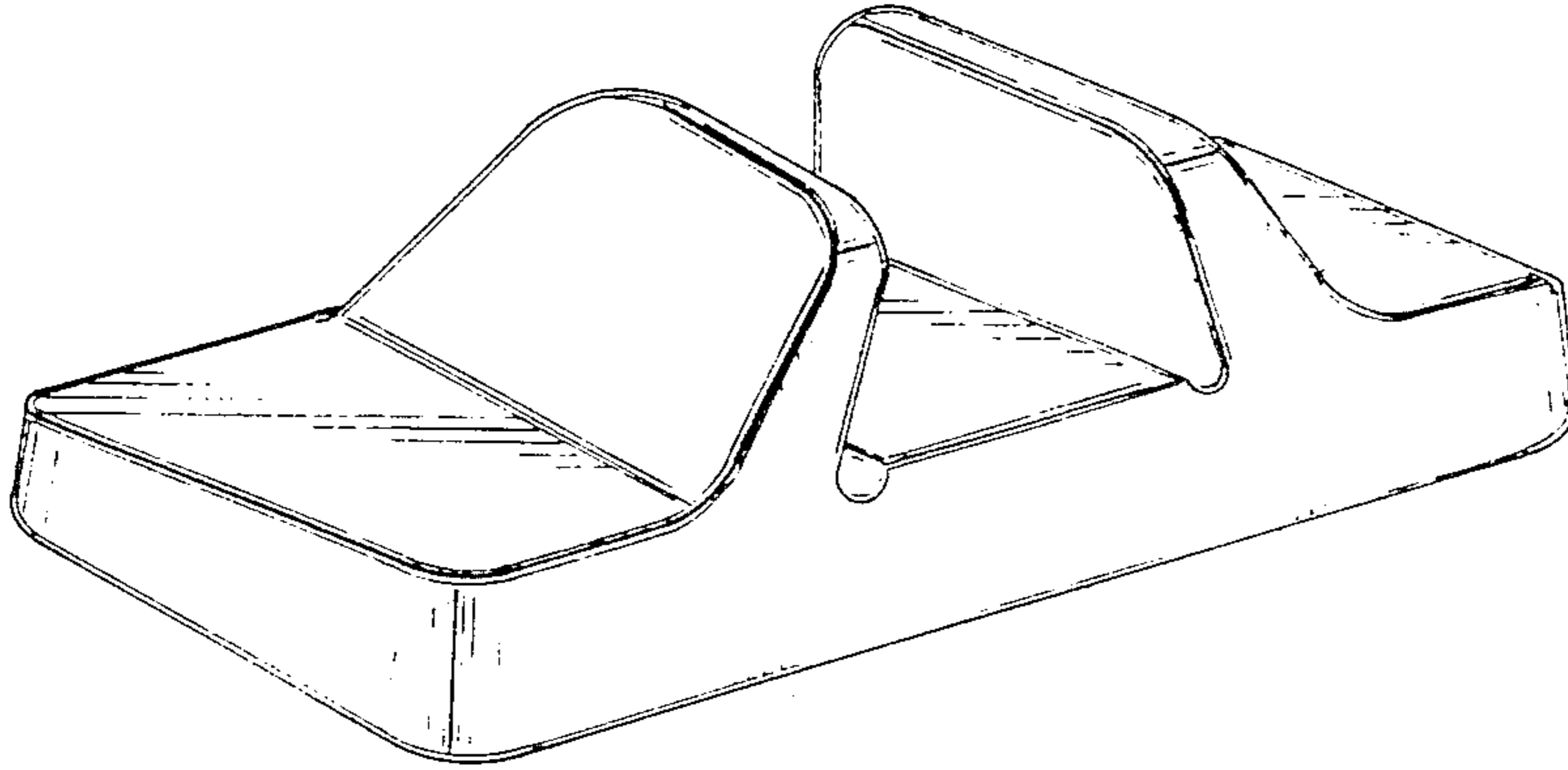

FIG 3

