

[54] ORGANIZER FOR HOLDING DRUG
DETECTION KIT ARTICLES OR THE LIKE

[76] Inventor: Mahendra K. Pandya, 8018 Daytona
Ave., NW., Massillon, Ohio 44646

[**] Term: 14 Years

[21] Appl. No.: 553,167

[22] Filed: Nov. 18, 1983

[52] U.S. Cl. D24/31; D19/75

[58] Field of Search D24/31, 32, 17; D3/74;
D19/75, 77-85, 90-92; 206/569; 211/126;
D28/73, 74

D. 251,644 4/1979 Raun D24/32
D. 269,574 7/1983 Dougherty D19/90
2,880,865 4/1959 Knox D24/32

Primary Examiner—George P. Word
Attorney, Agent, or Firm—Michael Sand Co.

[57] CLAIM

The ornamental design for an organizer for holding drug detection kit articles or the like, as shown and described.

DESCRIPTION

FIG. 1 is a perspective view of an organizer for holding drug detection kit articles or the like showing my new design;
FIG. 2 is a top plan view thereof;
FIG. 3 is a front elevational view thereof;
FIG. 4 is a left end elevational view thereof;
FIG. 5 is a right end elevational view thereof; and
FIG. 6 is a rear elevational view thereof.

[56] References Cited

U.S. PATENT DOCUMENTS

D. 183,031	6/1958	Tarte	D19/77
D. 202,393	9/1965	Wallenstein	D24/31
D. 225,785	1/1973	Geddis	D24/31
D. 239,334	3/1976	Lowenstein	D19/77

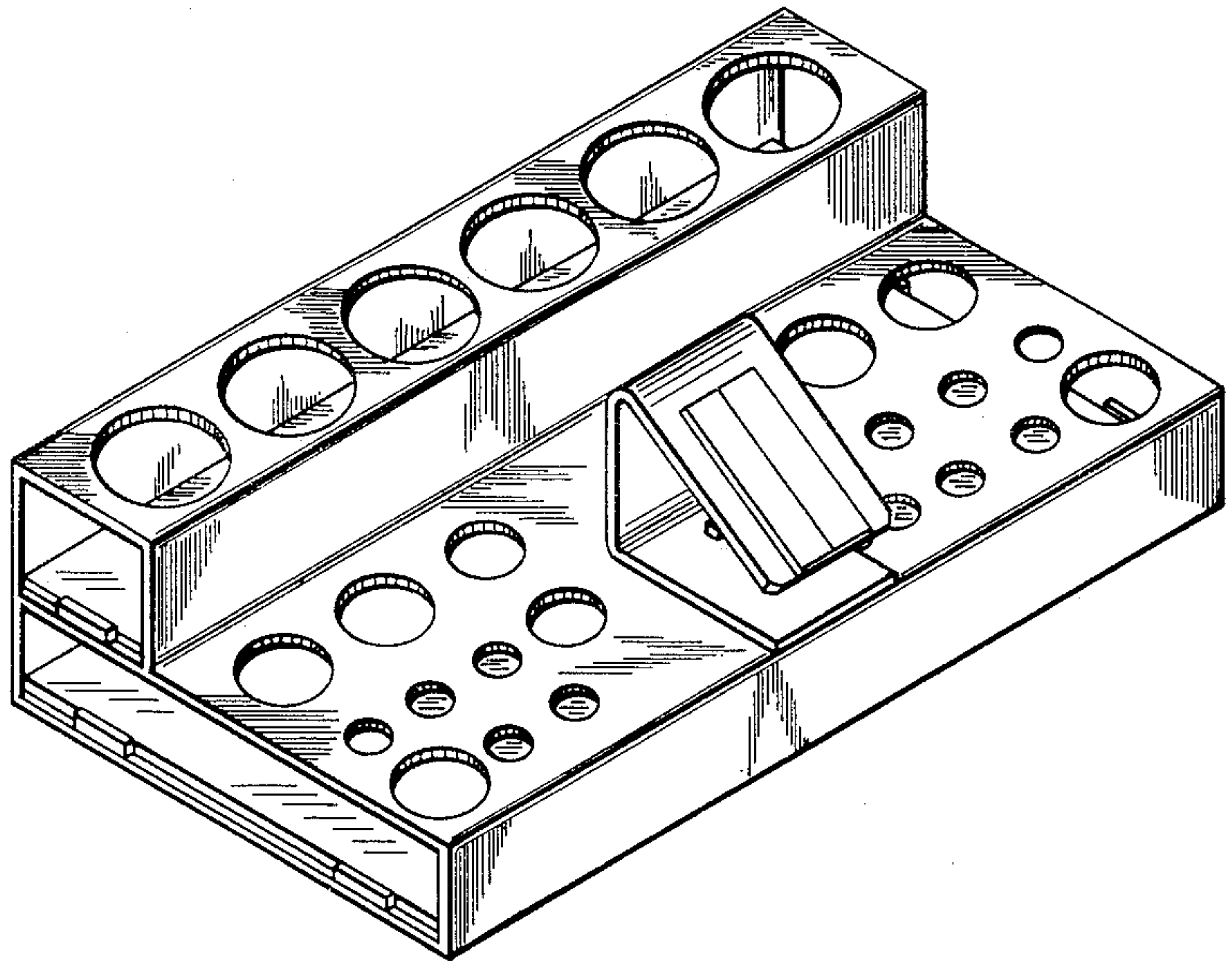

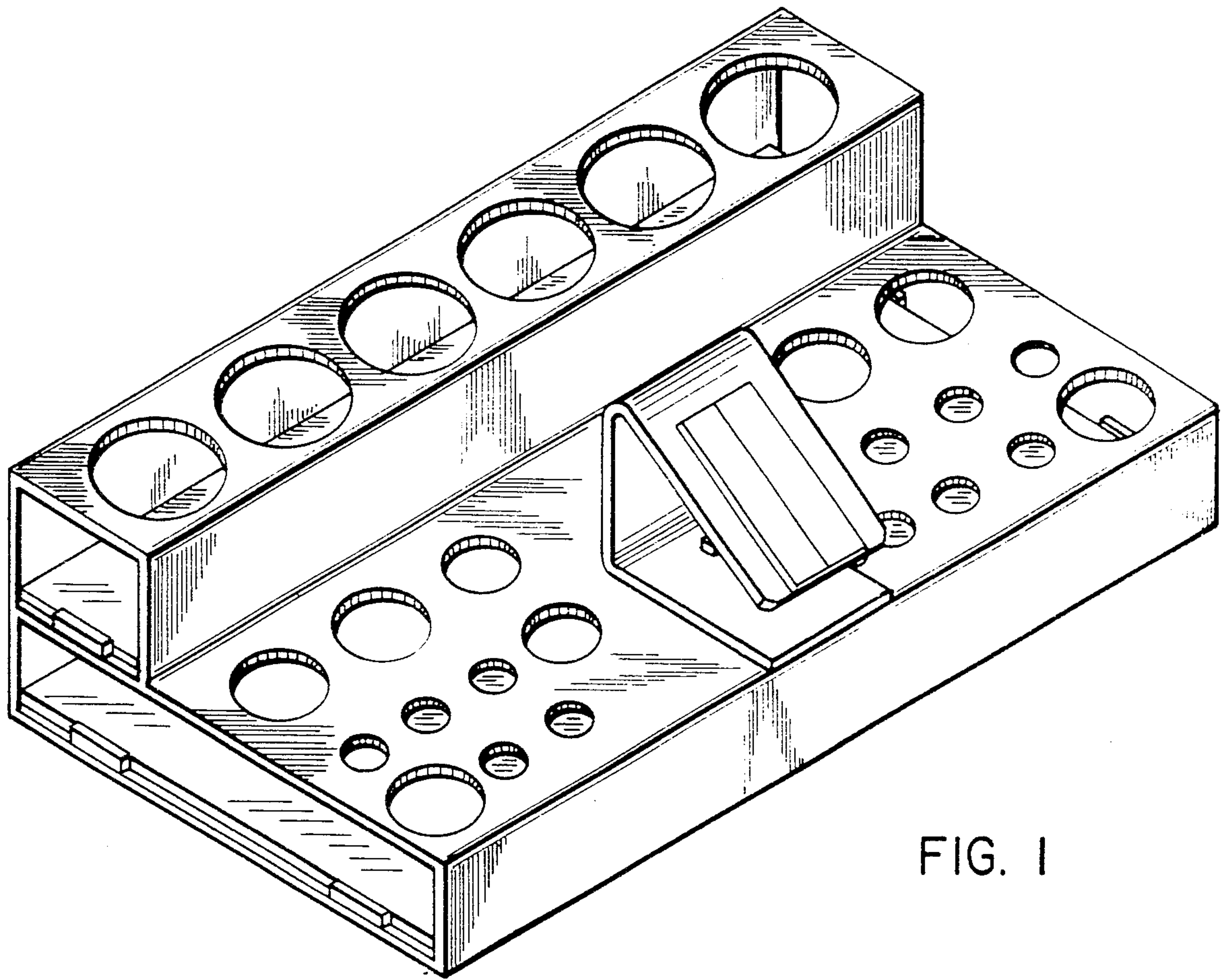

FIG. 1

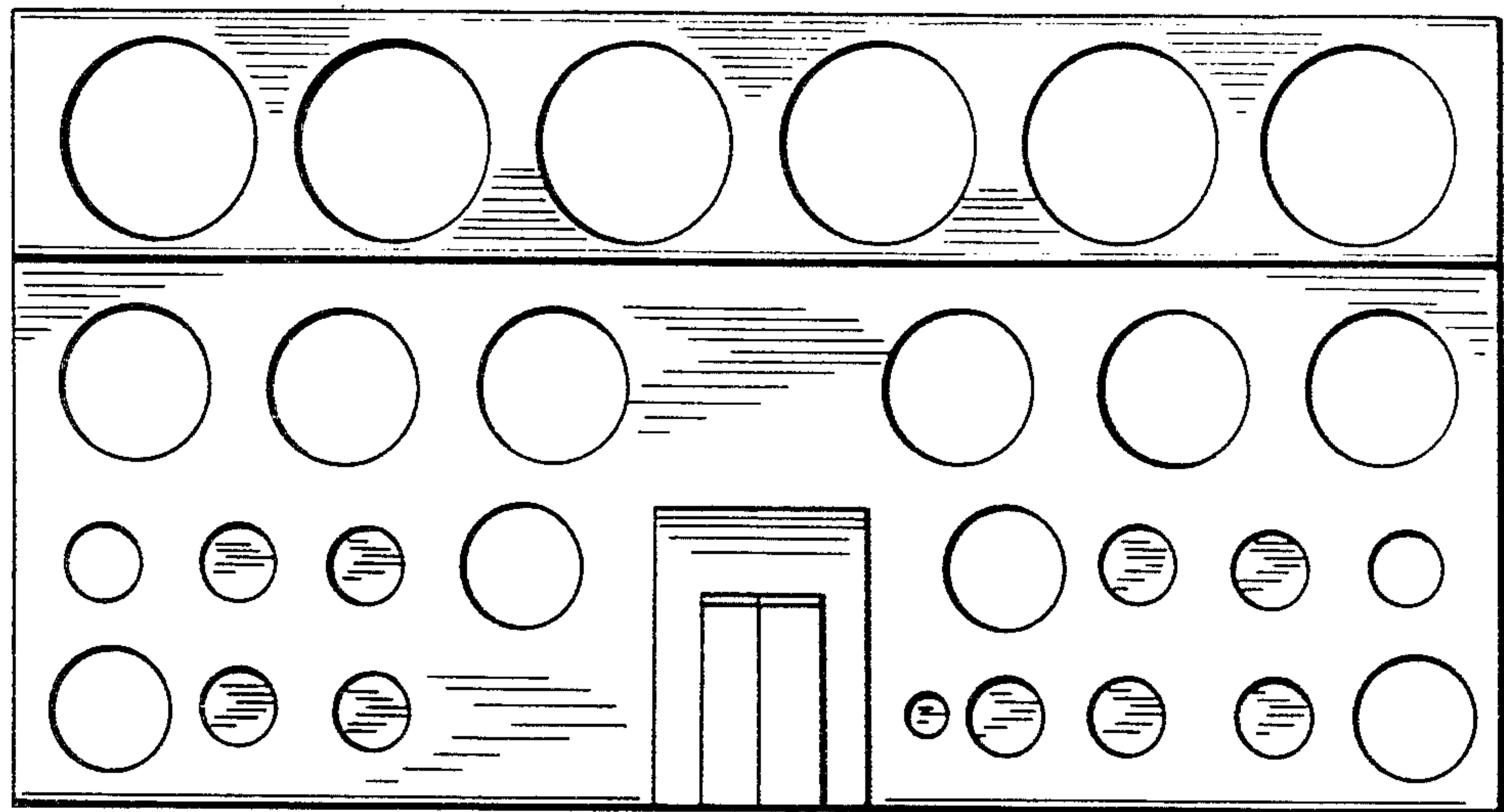

FIG. 2

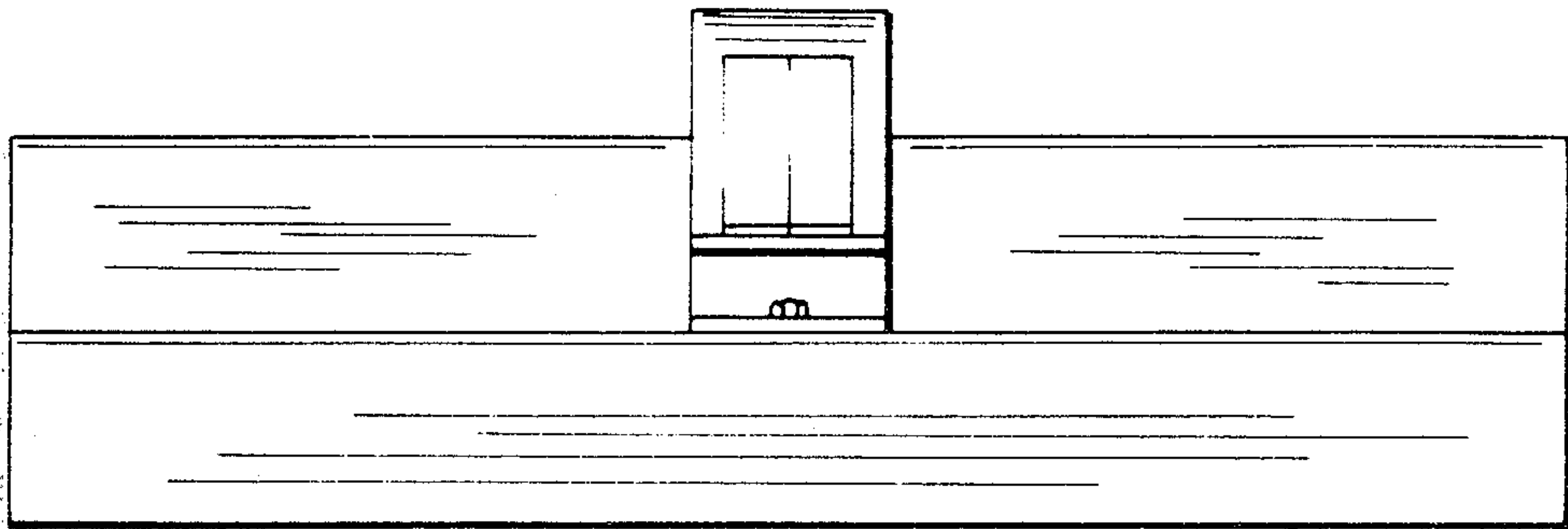

FIG. 3

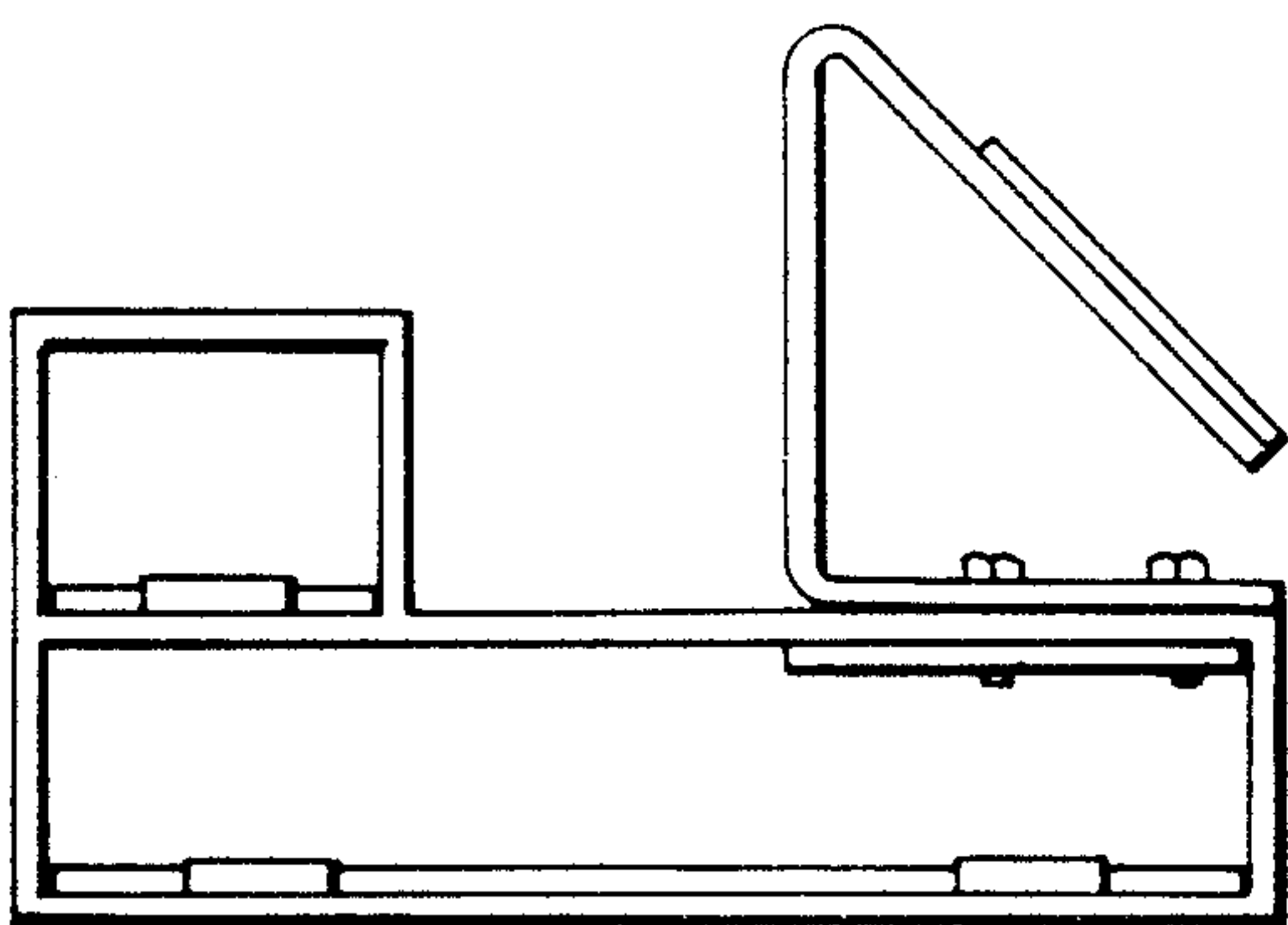

FIG. 4

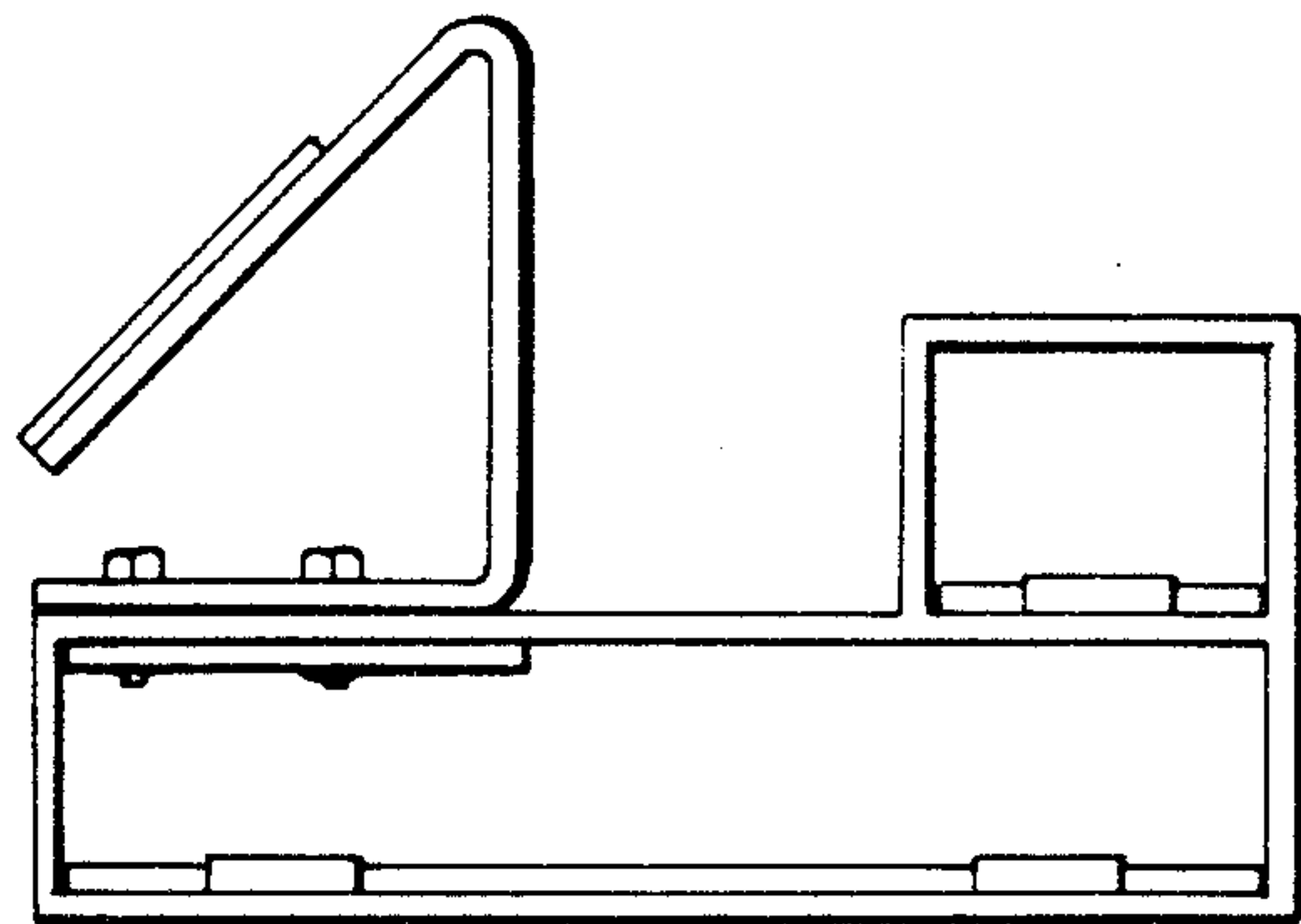

FIG. 5

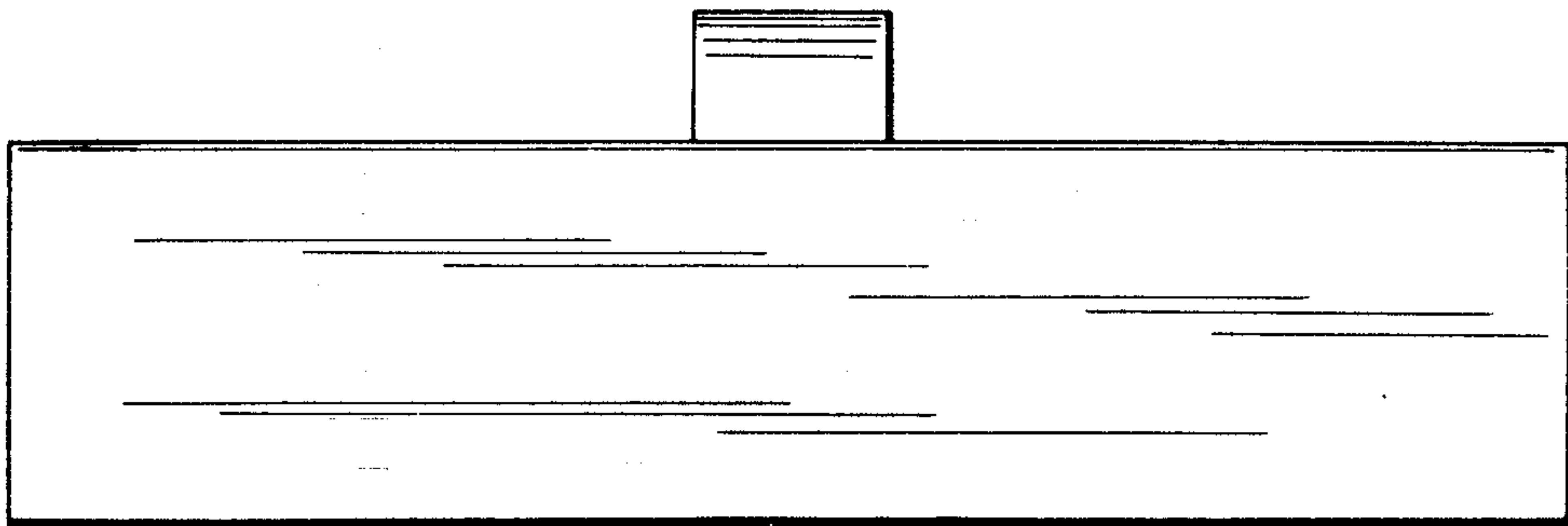

FIG. 6