

[54] SELF-PROPELLED AERIAL WORK PLATFORM

[75] Inventors: Azam S. Qureshi, Fullerton; William D. Murrill, Downey, both of Calif.

[73] Assignee: Calavar Corporation, Santa Fe Springs, Calif.

[**] Term: 14 Years

[21] Appl. No.: 505,361

[22] Filed: Jun. 16, 1983

[52] U.S. Cl. D34/34; 182/2

[58] Field of Search D34/34, 28; D12/56, D12/57; 182/2

[56] References Cited

U.S. PATENT DOCUMENTS

- D. 205,835 9/1966 Slusher D34/34
- D. 227,091 6/1973 Grove et al. D34/34

- D. 262,279 12/1981 Rallis et al. D34/34
- 3,937,340 2/1976 Grove 182/2
- 4,226,300 10/1980 Rallis et al. 182/2
- 4,456,093 6/1984 Finley et al. 182/2
- 4,458,780 7/1984 Telfer 182/2

Primary Examiner—Wallace R. Burke
Assistant Examiner—Brian N. Vinson

[57] CLAIM

The ornamental design for a self-propelled aerial work platform, as shown.

DESCRIPTION

FIG. 1 is a perspective view of a self-propelled aerial work platform embodying our new design;
 FIG. 2 is a top plan view thereof;
 FIG. 3 is a side elevational view thereof, taken from the right in FIG. 1;
 FIG. 4 is a front elevational view thereof; and
 FIG. 5 is a rear elevational view thereof.

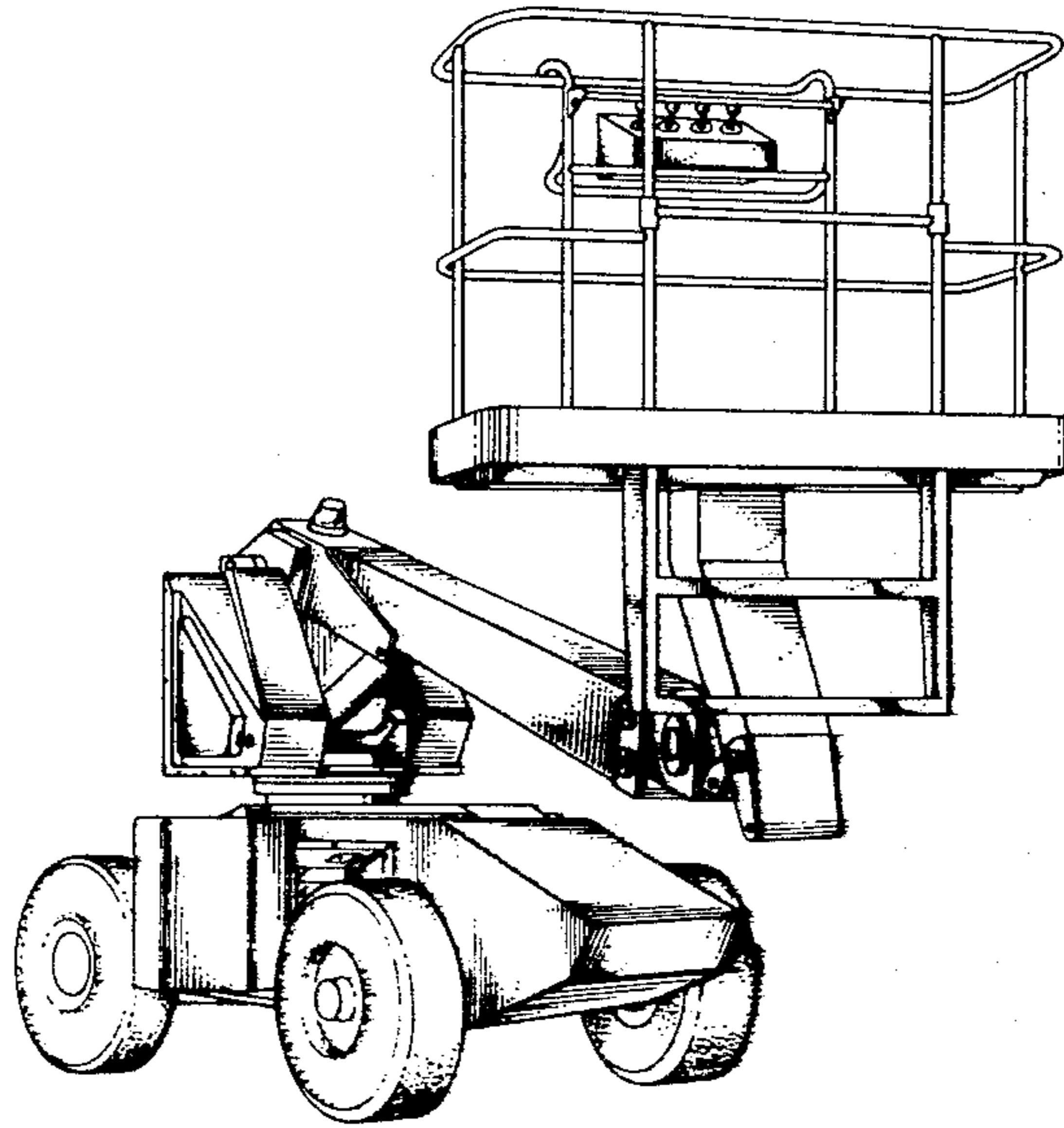

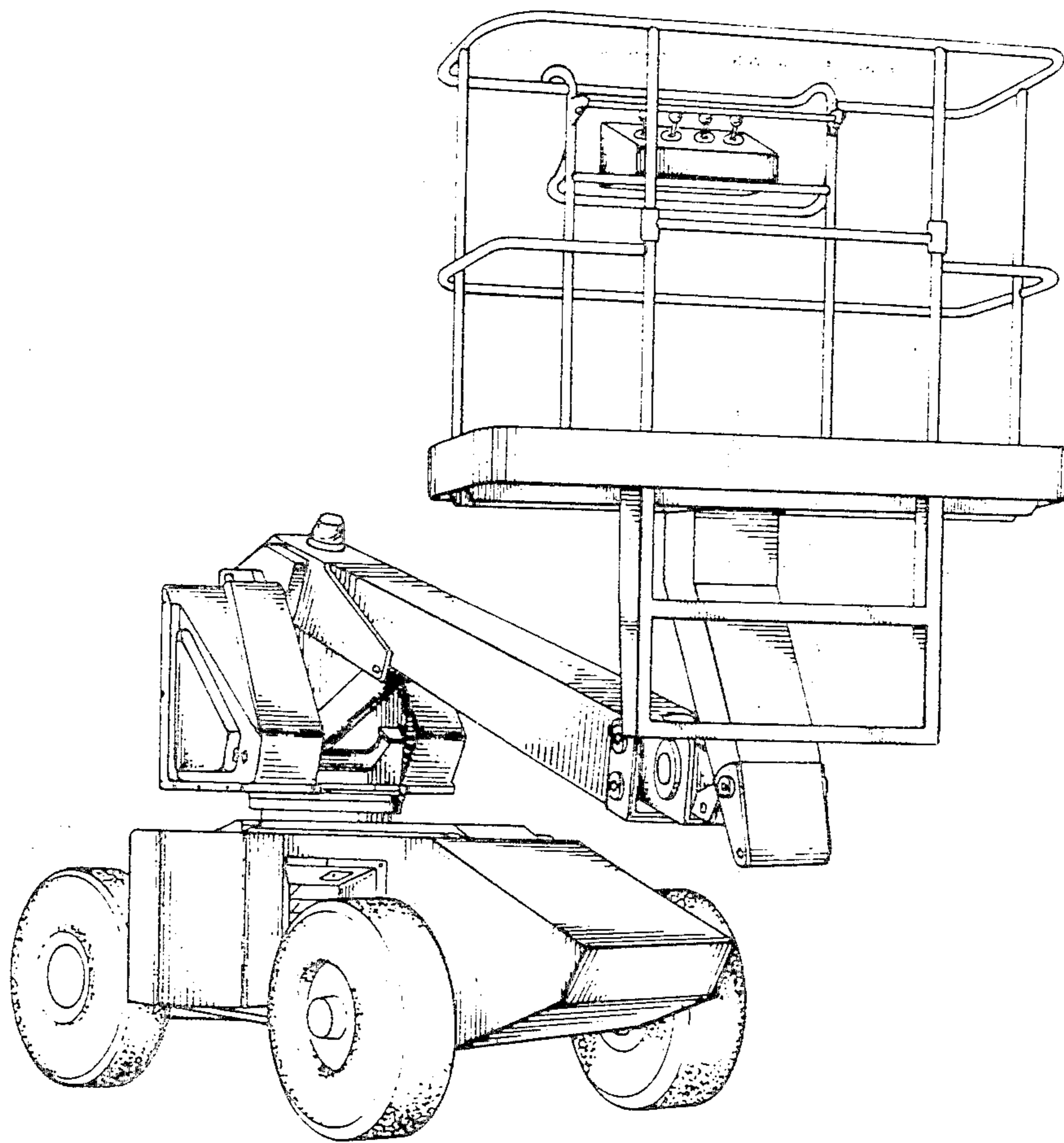

FIG. 1

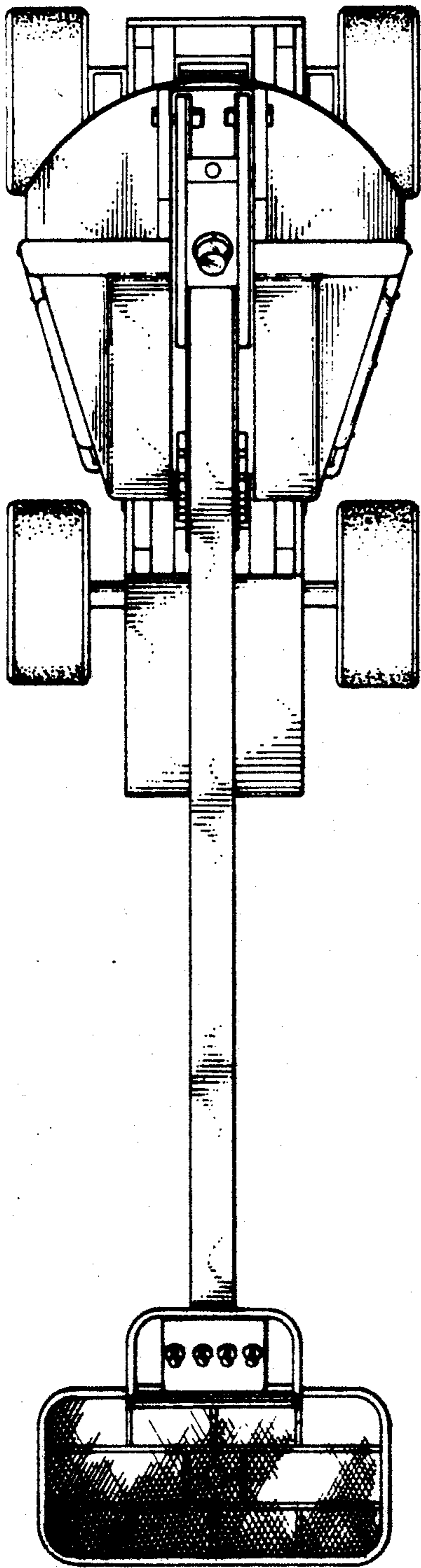

FIG. 2

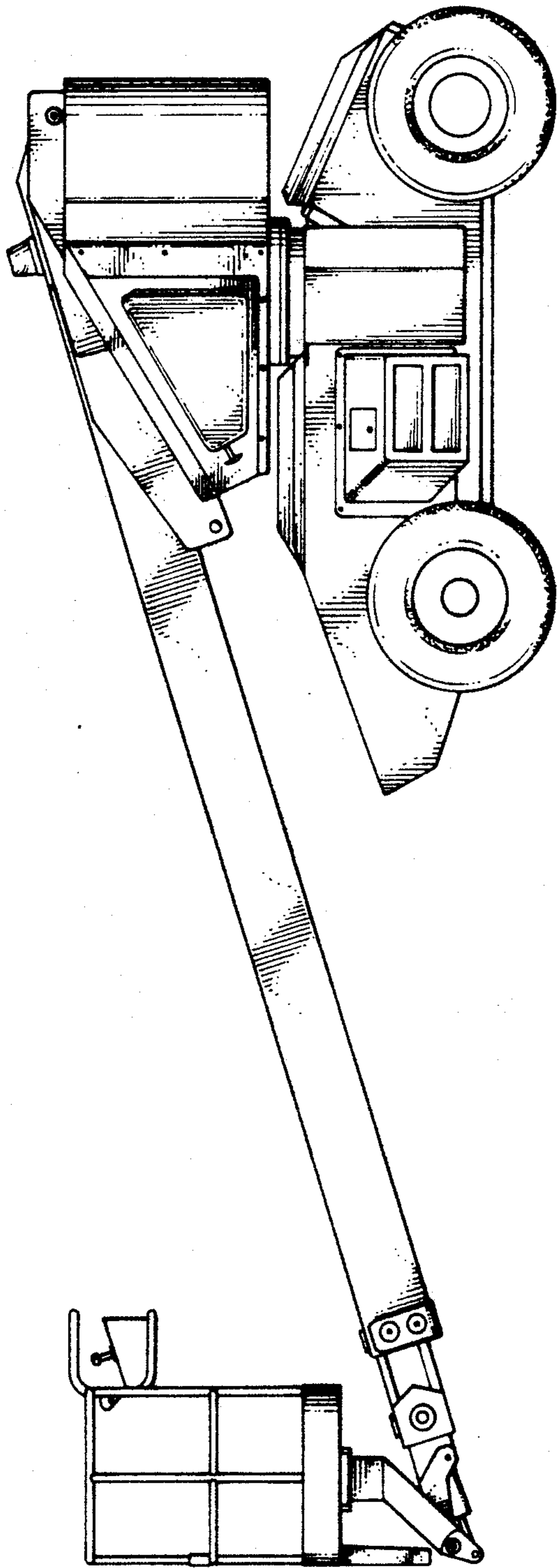

FIG. 3

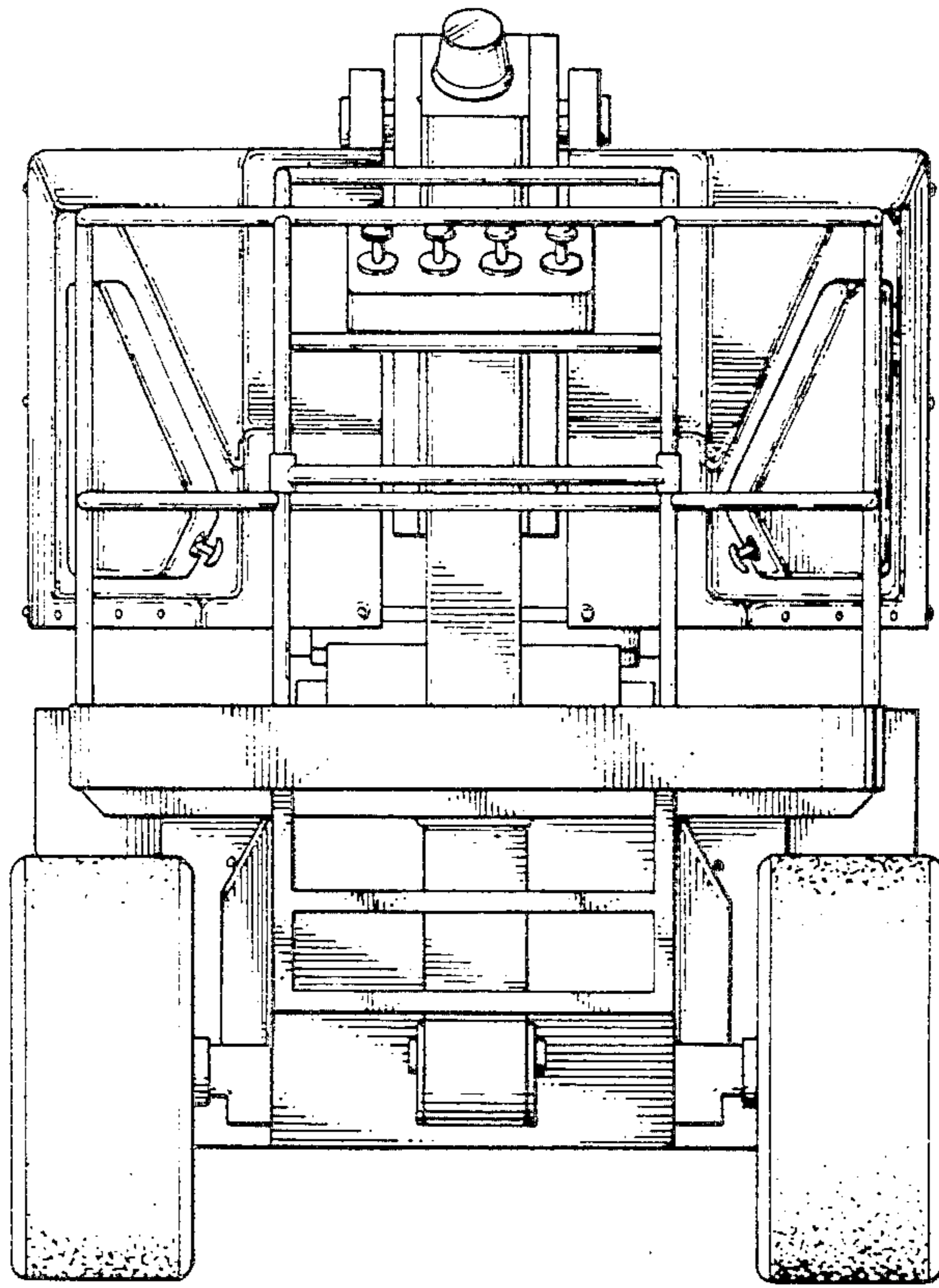

FIG. 4

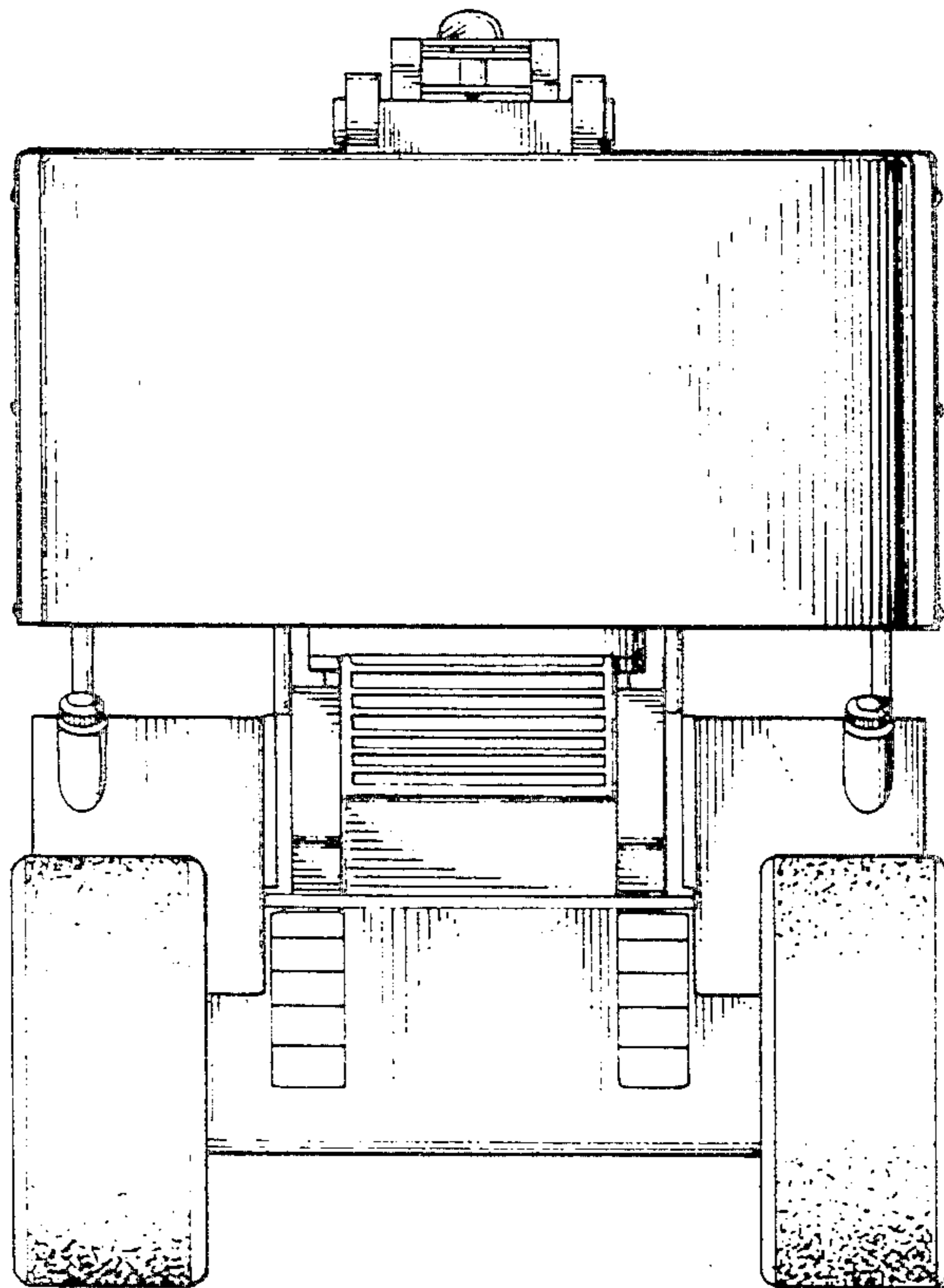

FIG. 5