

[54] LAMP

[76] Inventor: **Henricus J. Ansems**, Spoorwegstraat 14, 6828 AS Arnhem, Netherlands

[\*\*] Term: **14 Years**

[21] Appl. No.: **486,497**

[22] Filed: **Apr. 19, 1983**

[30] **Foreign Application Priority Data**

Oct. 19, 1982 [DE] Fed. Rep. of Germany ..... DMA/000157

[52] U.S. Cl. .... **D26/61**

[58] Field of Search ..... D26/61-66; 362/269, 271, 275, 277, 279, 413, 414, 418, 427

[56] **References Cited**

**U.S. PATENT DOCUMENTS**

D. 238,959 2/1976 Kurokawa ..... D26/62

**FOREIGN PATENT DOCUMENTS**

285933 9/1952 Switzerland ..... 362/413

**OTHER PUBLICATIONS**

Abitare Supplement, Lamps, p. 8, "Pala" Floor Lamp. Abitare Supplement, Lamps, p. 13, "Turisella" Lamp. Interiors, 2-1981, p. 28, Floor Lamp (bottom right).

*Primary Examiner*—Susan J. Lucas

*Attorney, Agent, or Firm*—Nims Howes Collison & Isner

[57] **CLAIM**

The ornamental design for a lamp or similar article, substantially as shown and described.

**DESCRIPTION**

FIGS. 1, 2, 3 and 4 are perspective views of a lamp or similar article showing my new design, the adjustable lamp being shown in alternate positions.

FIG. 5 is a fragmentary perspective view of the base taken from the sides opposite those shown in FIGS. 1-4;

FIG. 6 is a fragmentary perspective view of the under-surface of the lamp reflector.

The lamp is fragmentarily shown in FIGS. 5 and 6 for convenience of illustration.

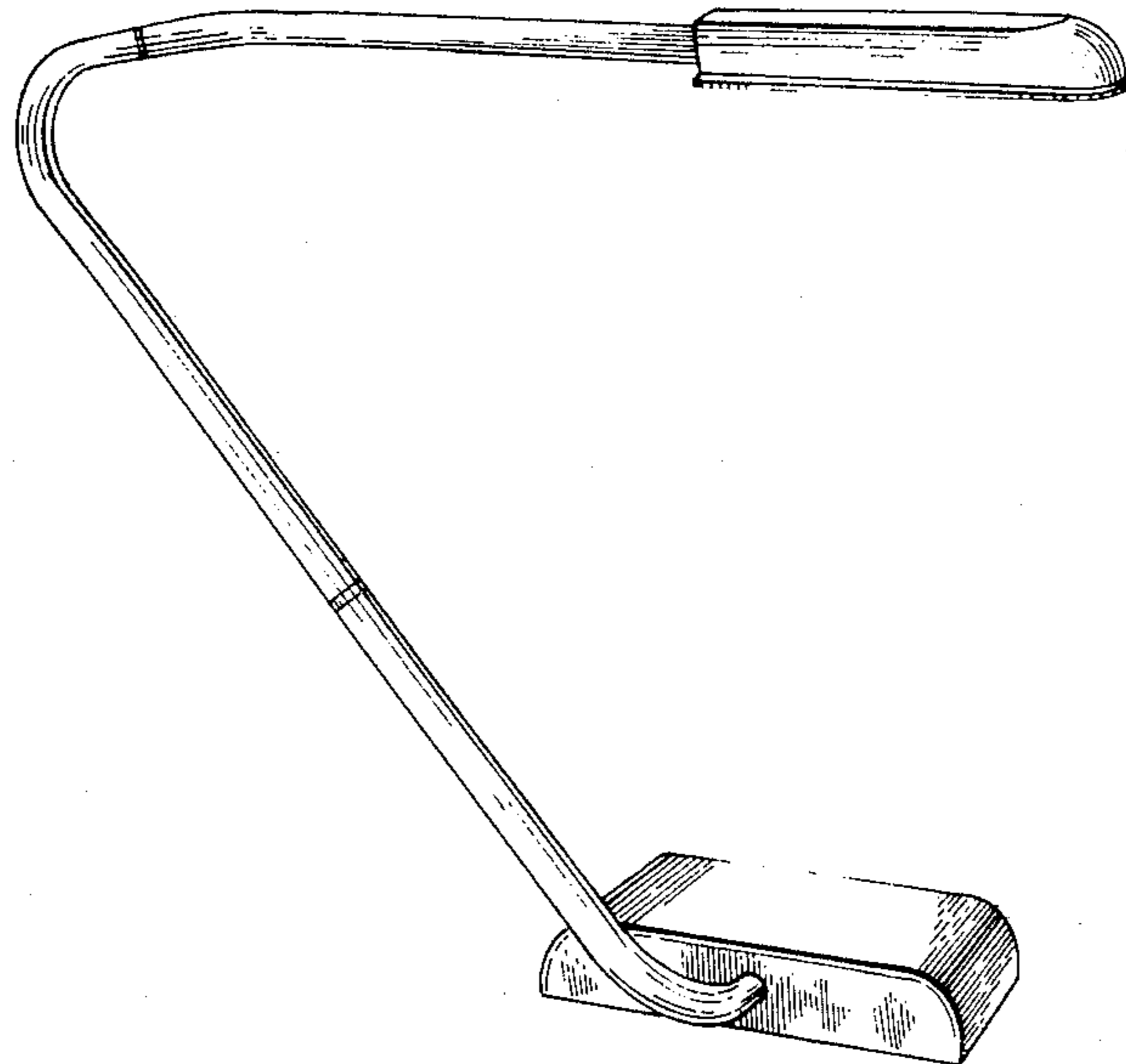

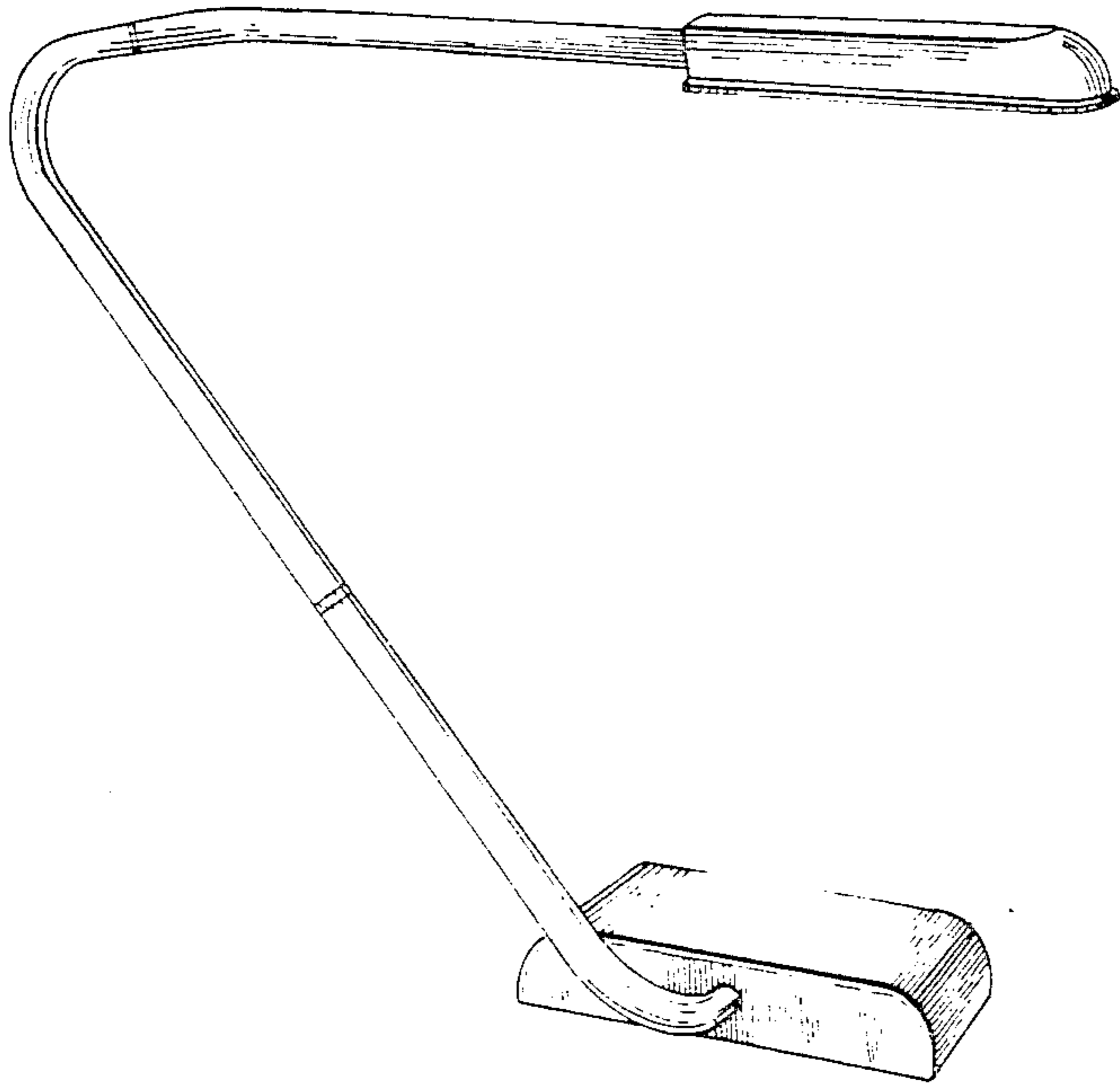

FIG. 1

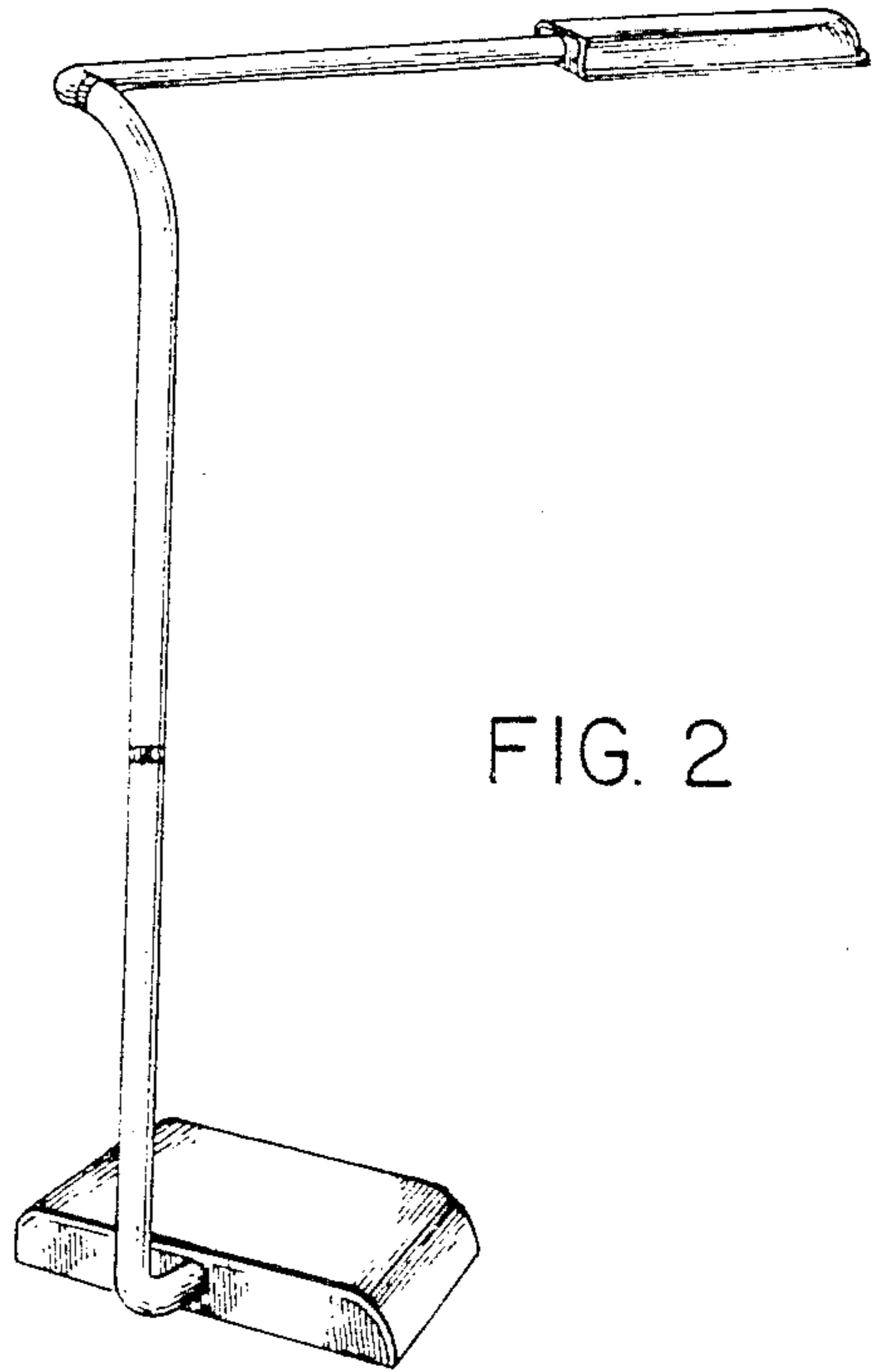

FIG. 2

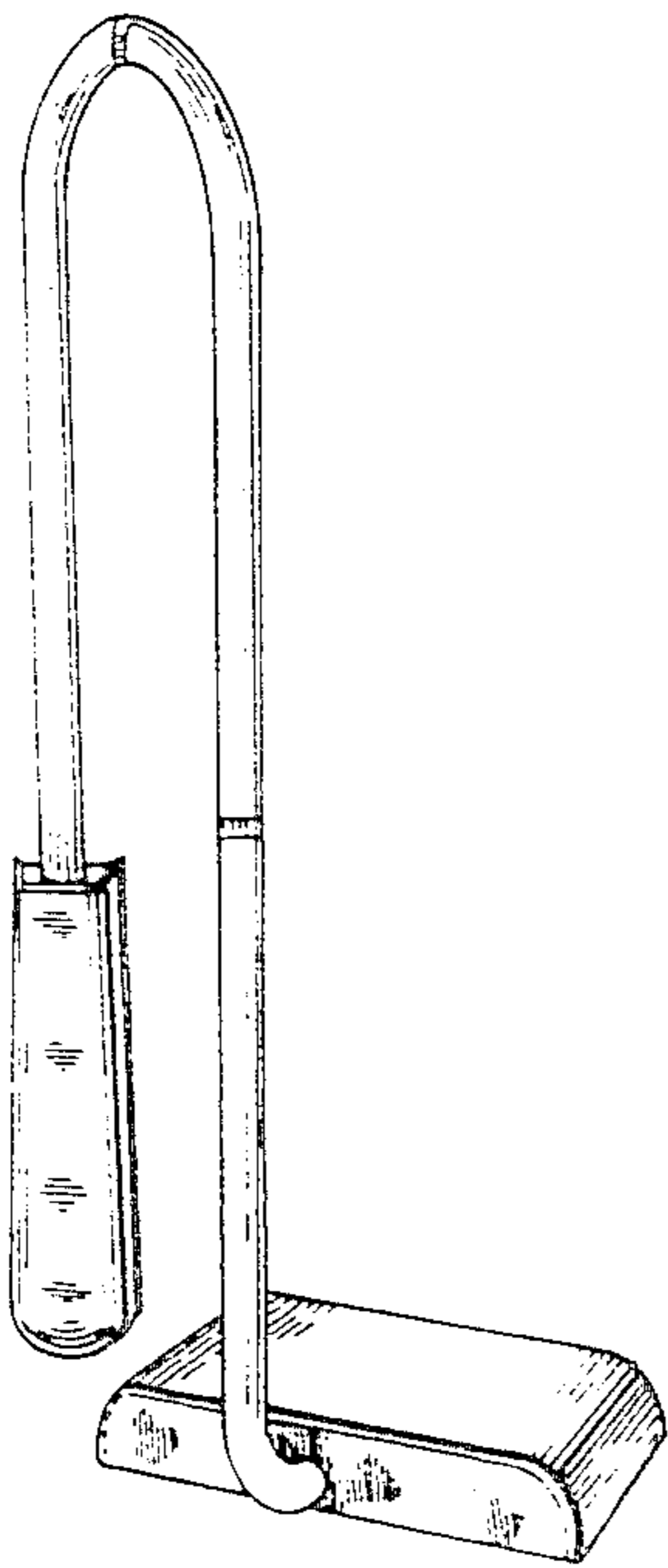

FIG. 3

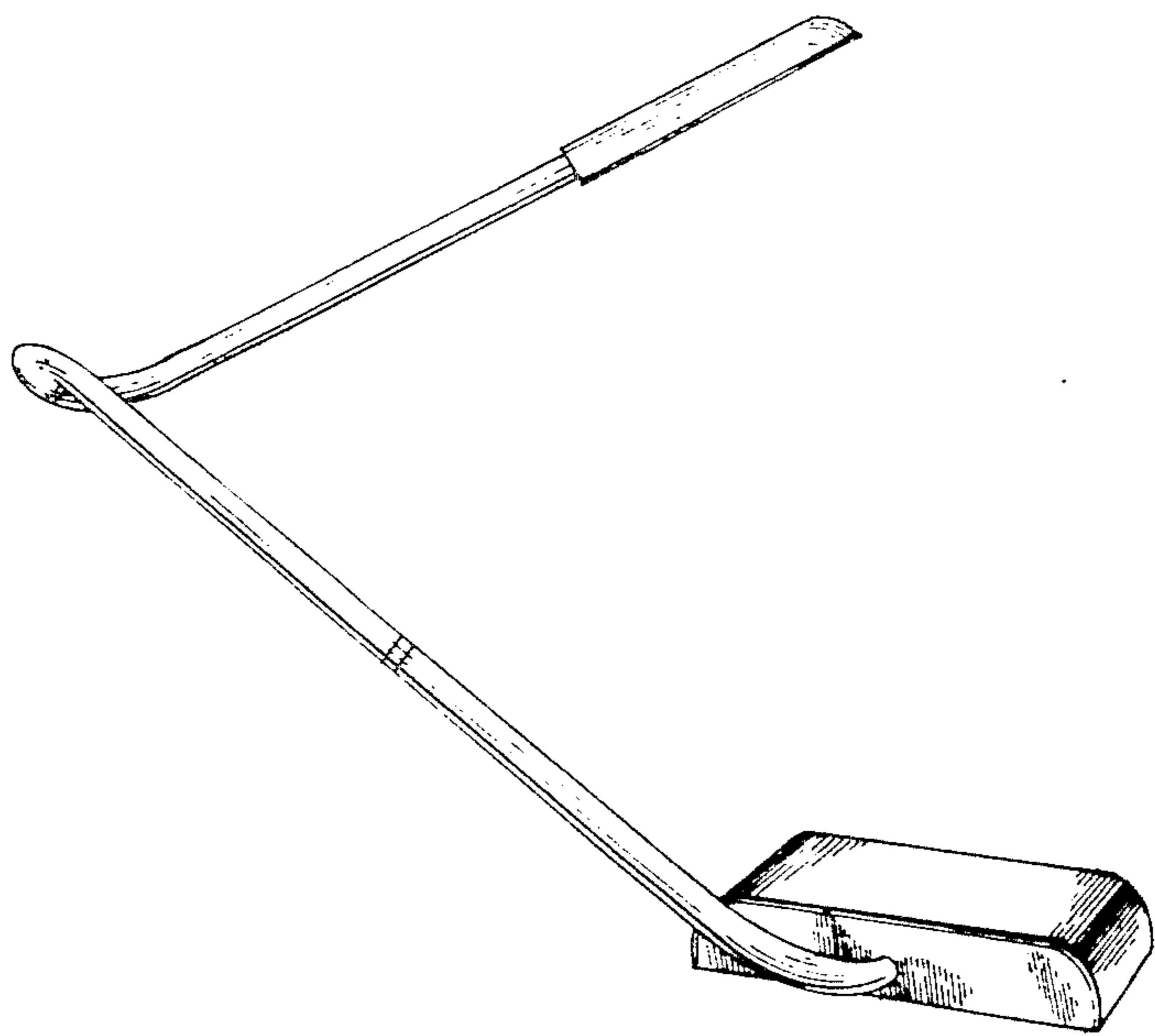

FIG. 4

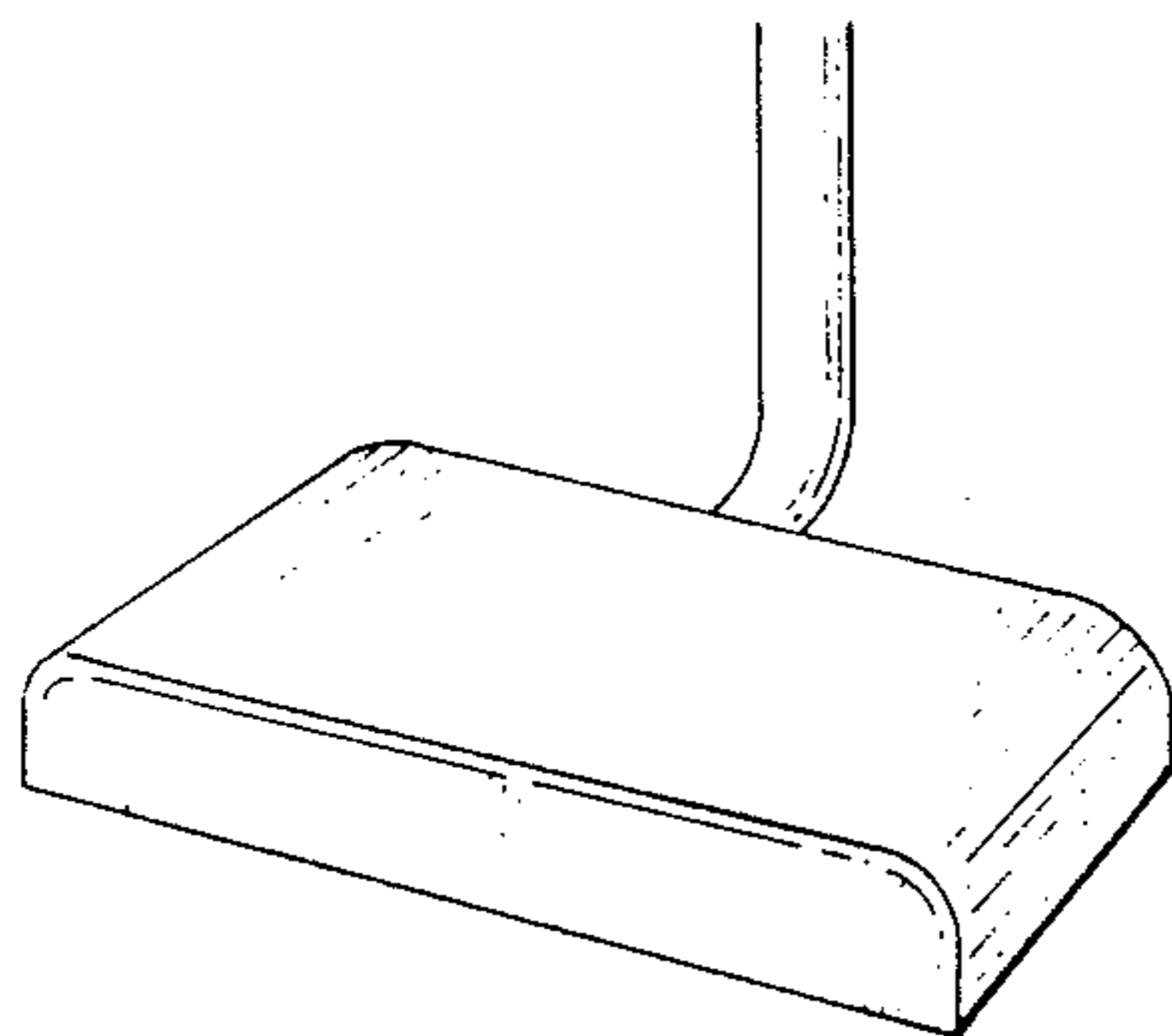

FIG. 5

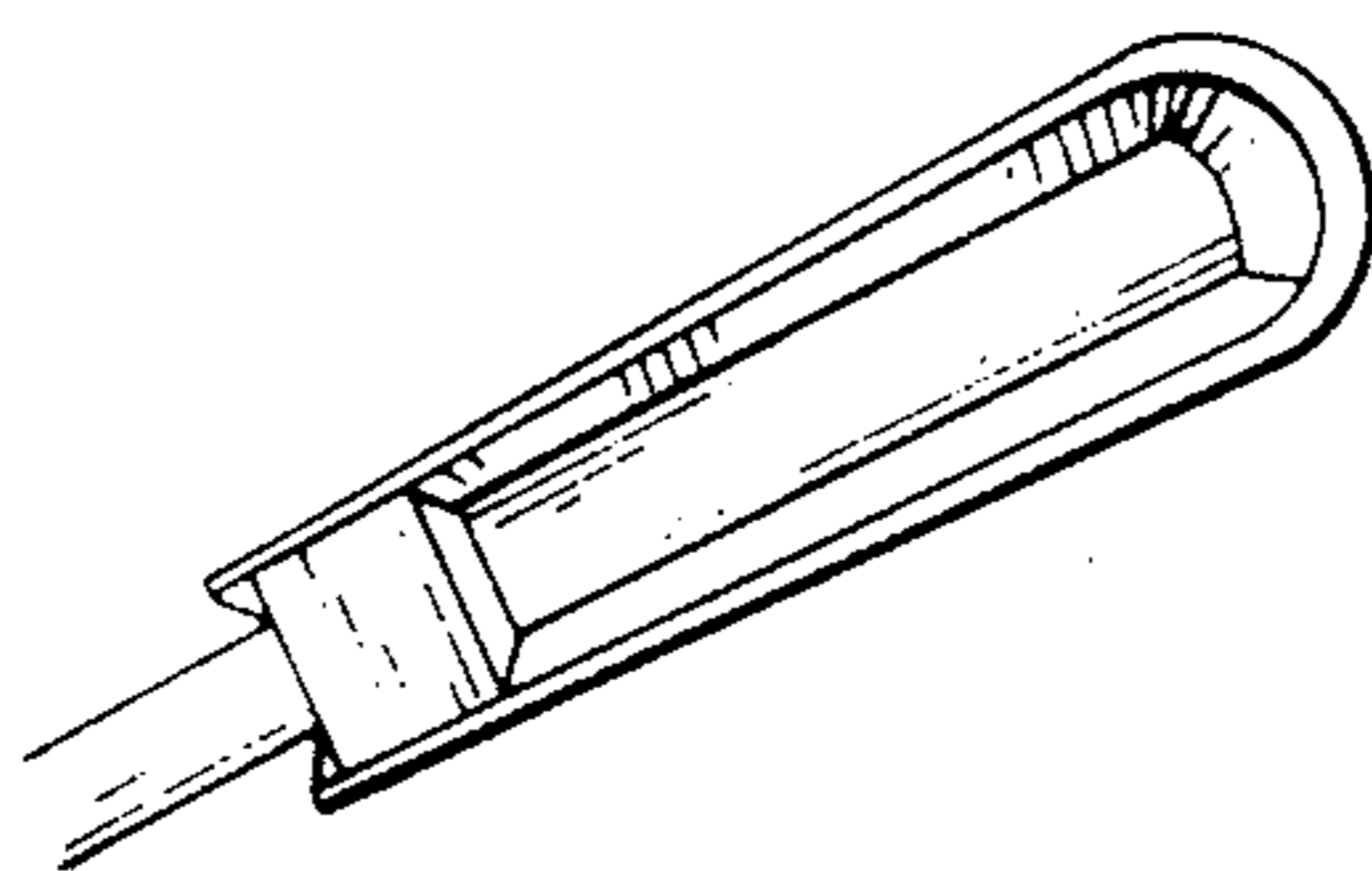

FIG. 6