

[54] ORGANIZER FOR HOLDING DRUG DETECTION KIT ARTICLES OR THE LIKE

D. 251,644 4/1979 Ravn D24/32
D. 269,574 7/1983 Dougherty D19/90
2,880,865 4/1959 Knox D24/32

[76] Inventor: Mahendra K. Pandya, 8018 Daytona Ave., N.W., Massillon, Ohio 44646

Primary Examiner—George P. Word
Attorney, Agent, or Firm—Michael Sand Co.

[**] Term: 14 Years

[57] CLAIM

[21] Appl. No.: 553,166

The ornamental design for an organizer for holding drug detection kit articles or the like, as shown and described.

[22] Filed: Nov. 18, 1983

[52] U.S. Cl. D24/31; D19/75

[58] Field of Search D24/31, 32, 17; D3/74; D19/75, 77, 85, 90, 92; 206/569; 211/126

DESCRIPTION

[56] References Cited

U.S. PATENT DOCUMENTS

D. 183,031 6/1958 Tarte D19/77
D. 202,393 9/1965 Wallerstein D24/31
D. 225,785 1/1973 Geddis D24/31
D. 239,334 3/1976 Lowenstein D19/77

FIG. 1 is a perspective view of an organizer for holding drug detection kit articles or the like showing my new design;

FIG. 2 is a top plan view thereof;

FIG. 3 is a front elevational view thereof;

FIG. 4 is a left end elevational view thereof;

FIG. 5 is a right end elevational view thereof; and

FIG. 6 is a rear elevational view thereof.

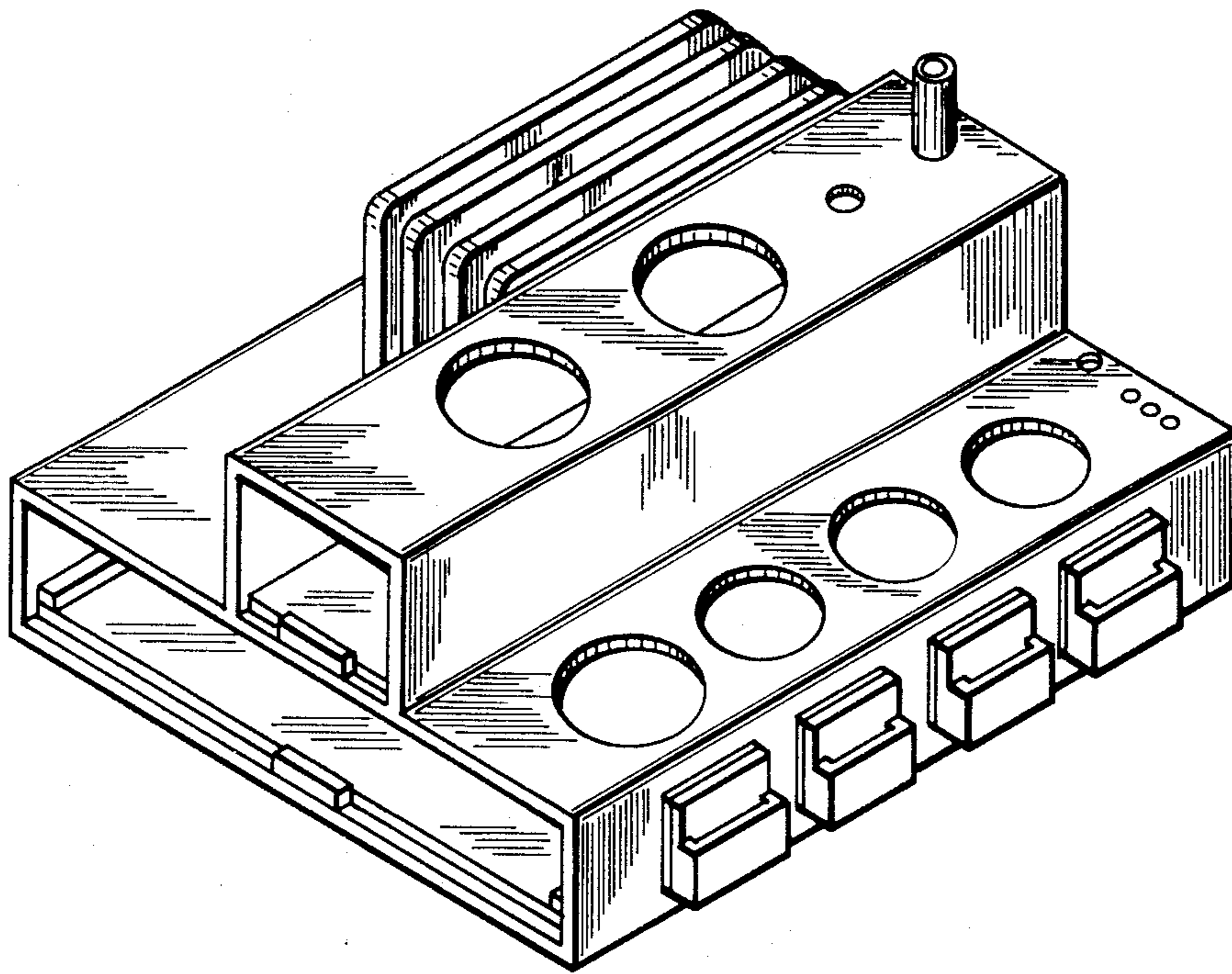

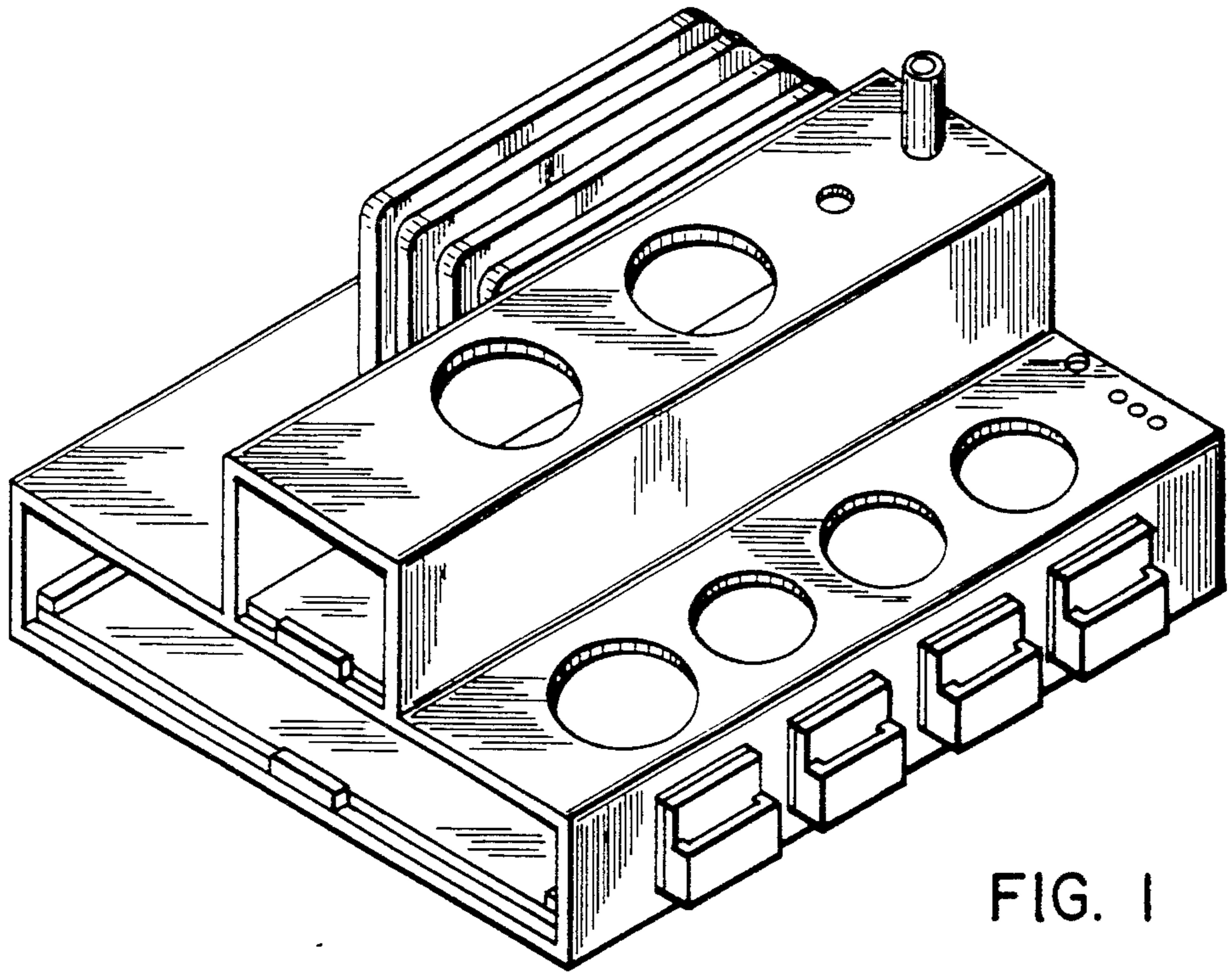

FIG. 1

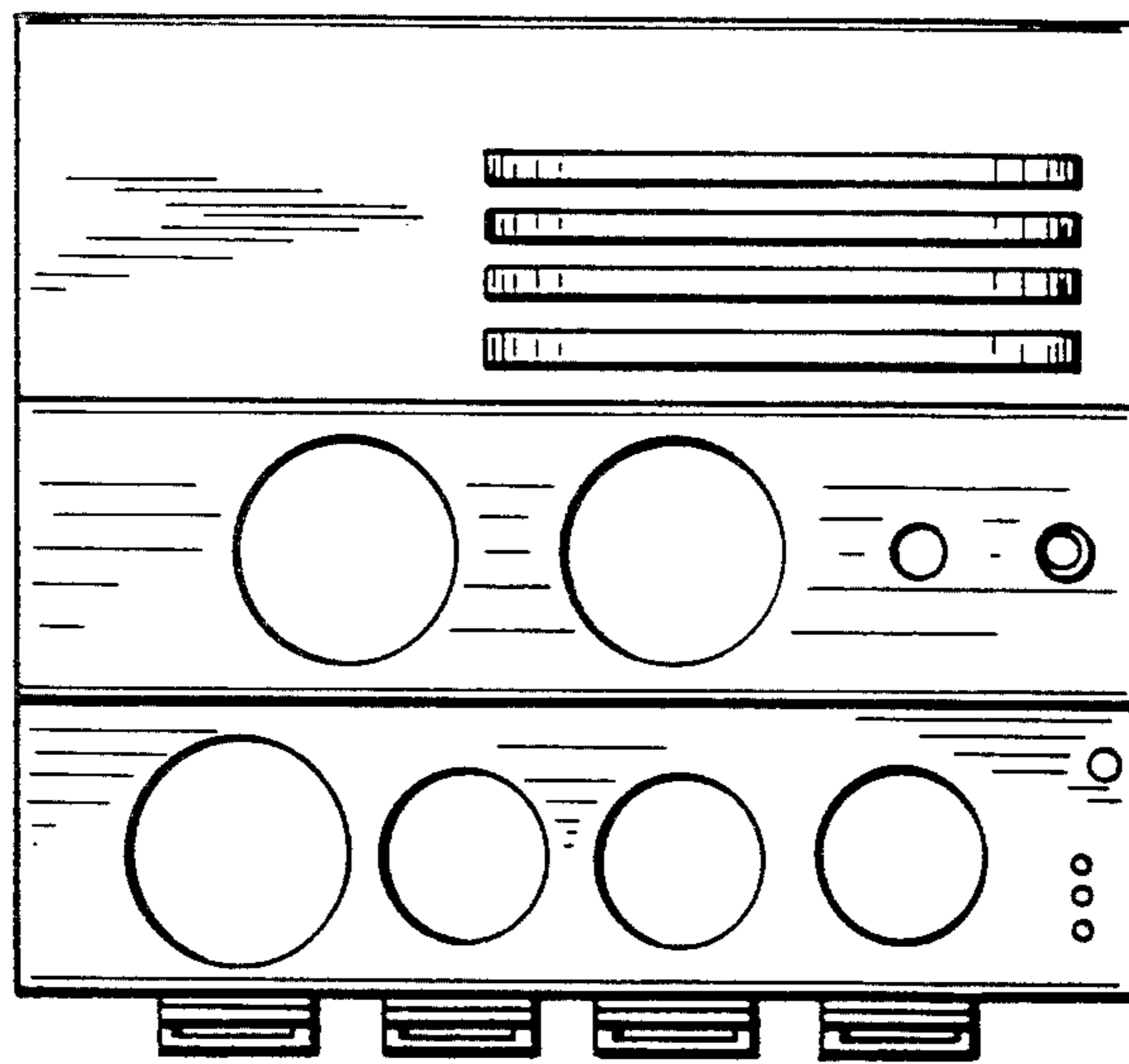

FIG. 2

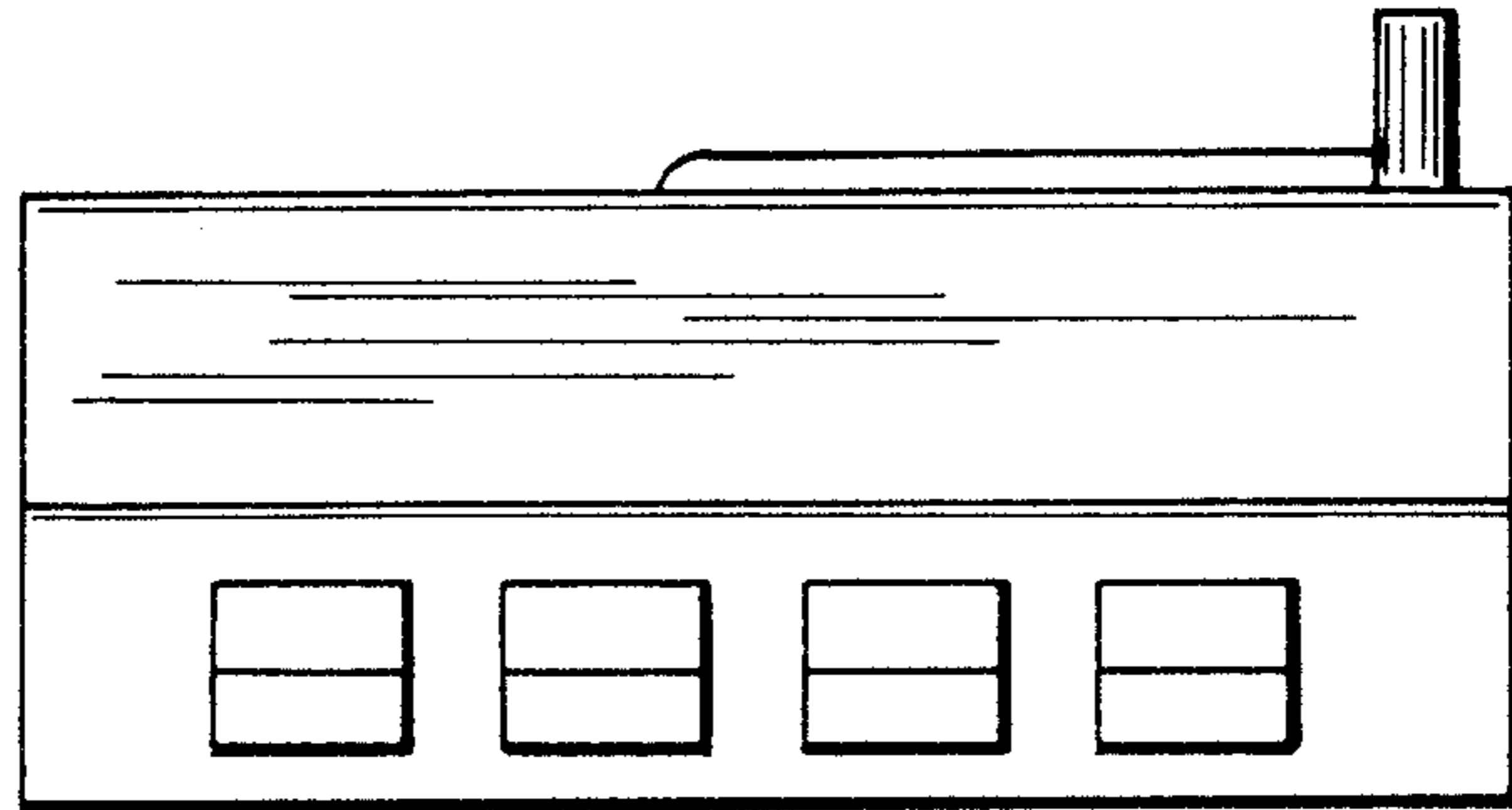

FIG. 3

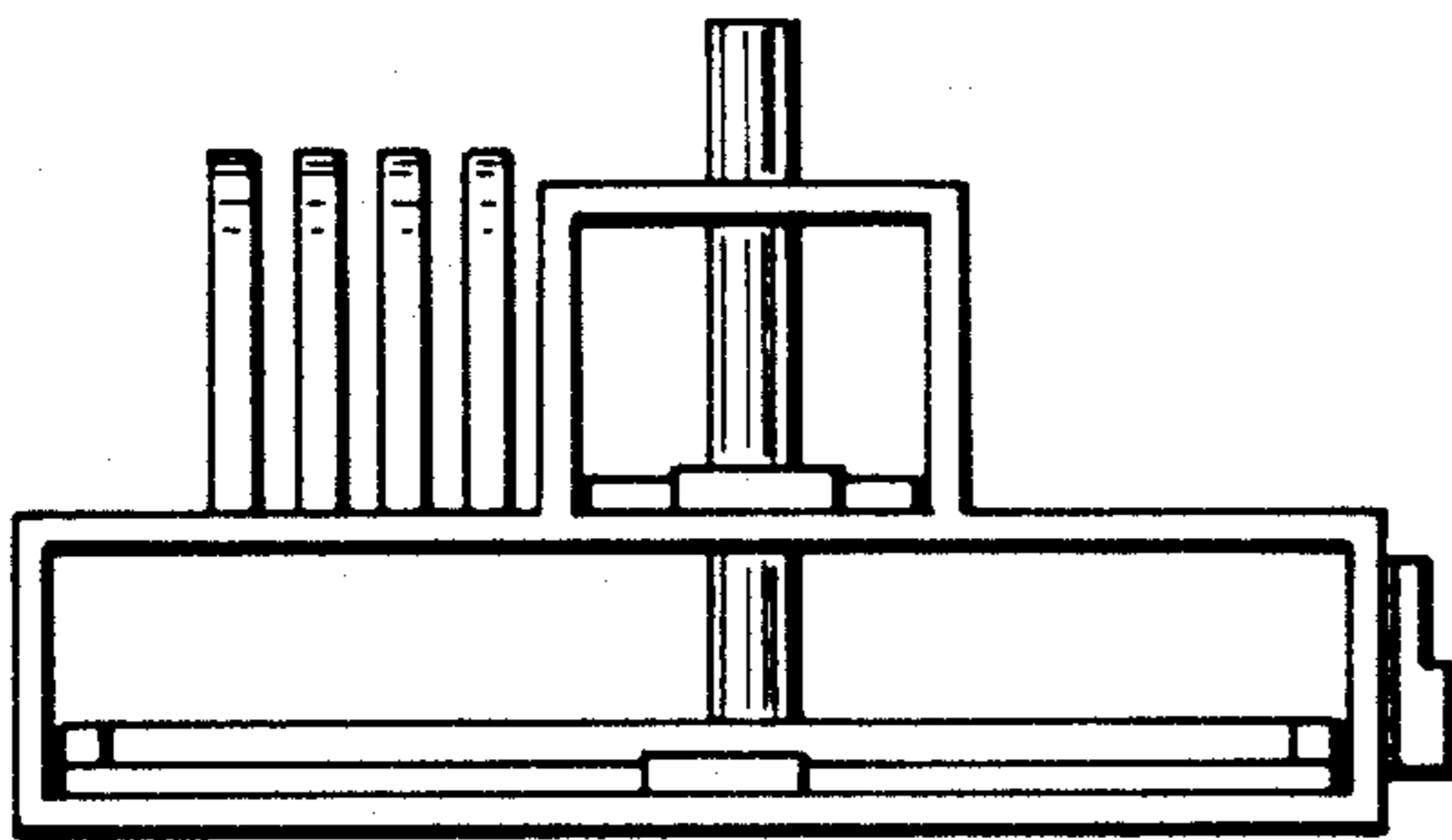

FIG. 4

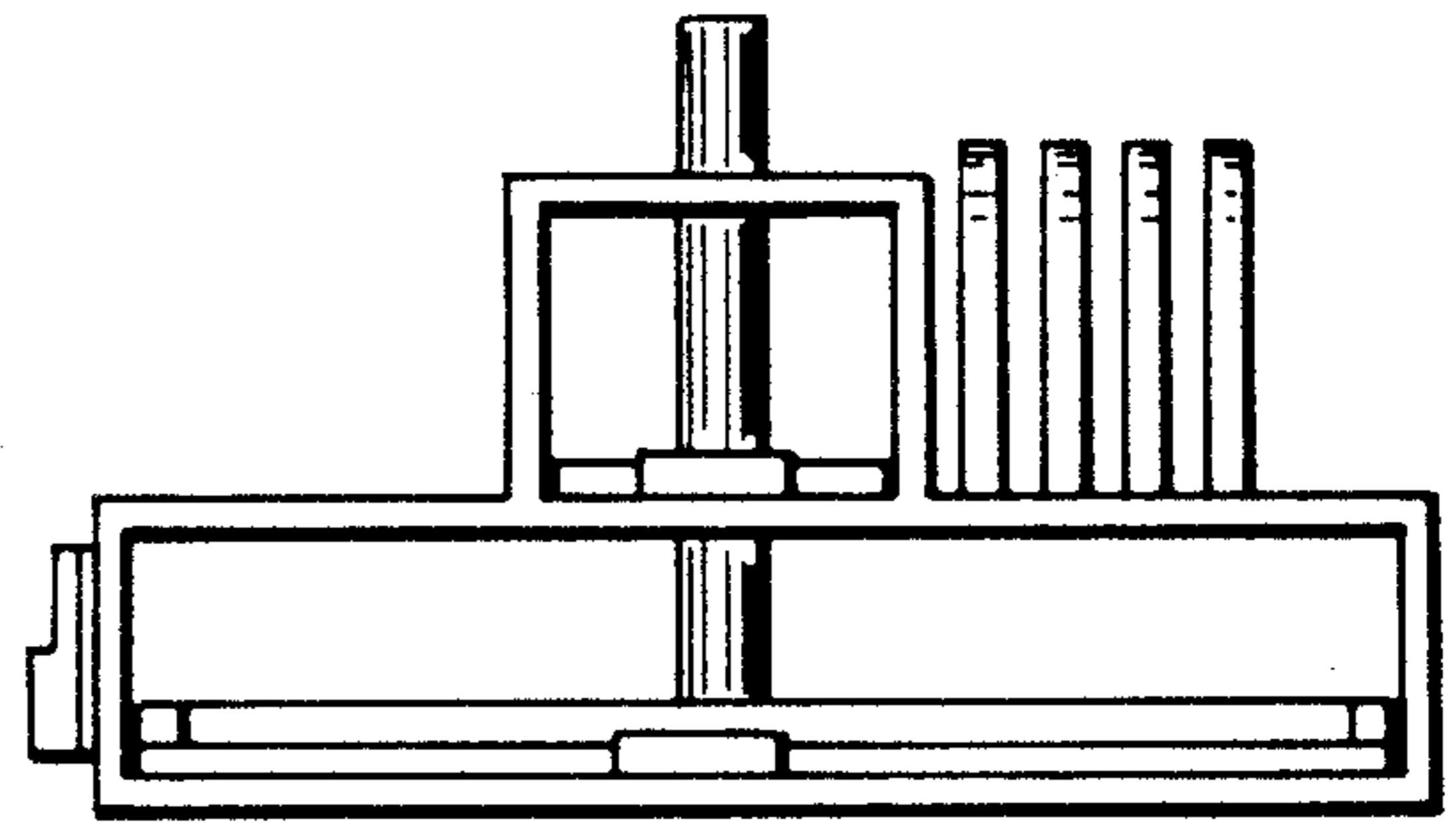

FIG. 5

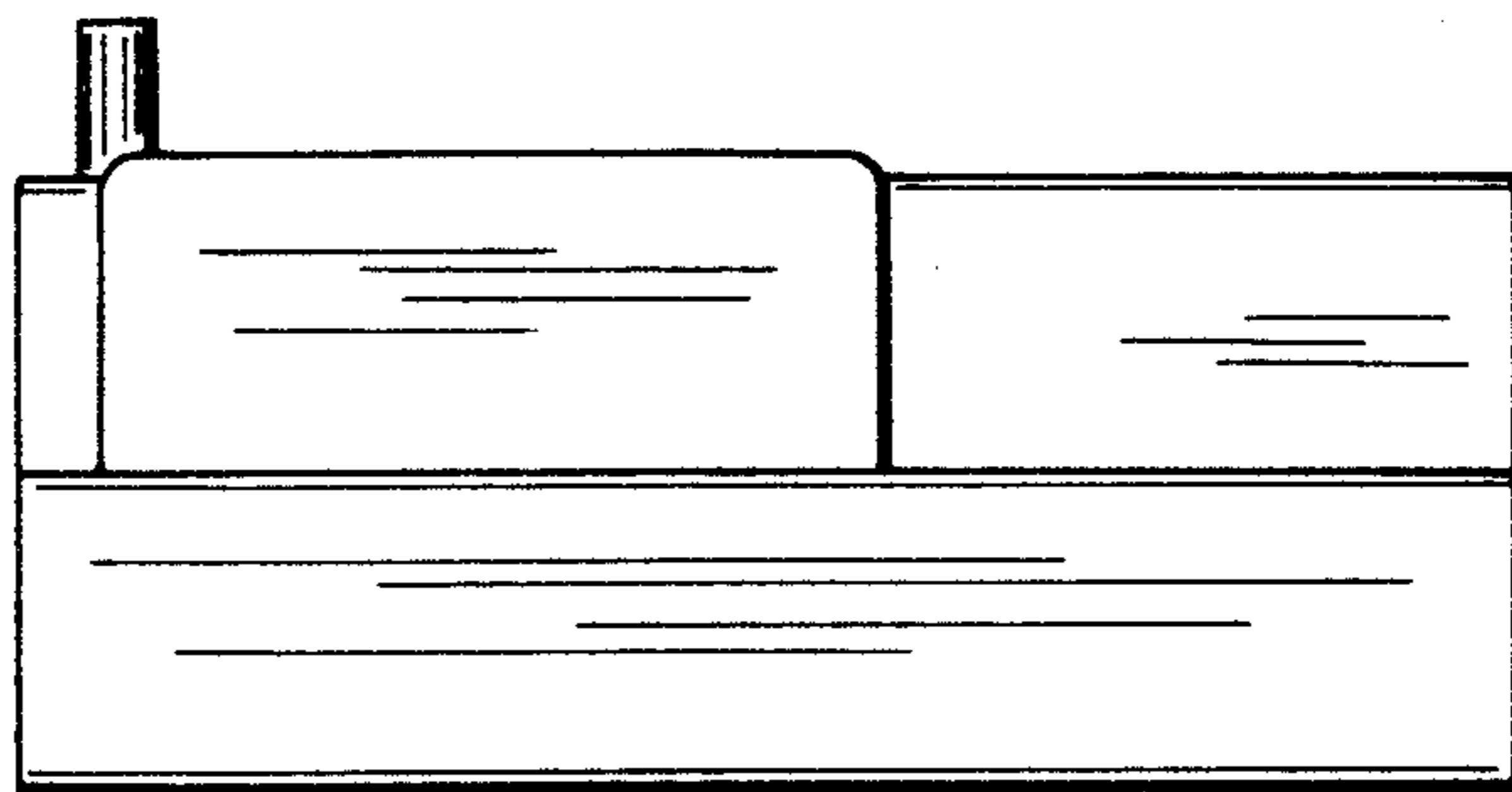

FIG. 6