

[54] **DUAL WHEEL COMBINATION LOCK FOR LUGGAGE OR SIMILAR TYPE ARTICLE-RETAINING CONTAINER**

[75] **Inventor: Urs Gisiger, Selzach, Switzerland**

[73] **Assignee: Amiet AG, Oberdorf, Switzerland**

[**] **Term: 14 Years**

[21] **Appl. No.: 461,470**

[22] **Filed: Jan. 27, 1983**

[30] **Foreign Application Priority Data**

Nov. 16, 1982 [Wo] d Int. Prop. O. 72755

[52] **U.S. Cl. D8/331; 70/312**

[58] **Field of Search D8/330, 331, 338, 339, D8/341, 344; 70/312, 306, 316; D3/76**

[56] **References Cited**

U.S. PATENT DOCUMENTS

D. 191,372	9/1961	Storey	D8/338
D. 201,988	8/1965	Geshrie	D8/341
D. 209,083	10/1967	Gehrie	D8/338
D. 233,959	12/1974	Bako	D8/331
D. 253,747	12/1979	Stolarz	D8/338
D. 270,425	9/1983	Stolarz	D8/341
D. 274,305	6/1984	Gisiger	D8/338
D. 275,823	10/1984	Seynhaeve	D3/76
D. 276,130	10/1984	Gisiger	D8/330
2,007,663	7/1935	Rapp	70/306
3,776,006	12/1973	Atkinson	70/312
3,973,419	8/1976	Atkinson	70/312
4,155,234	5/1979	Bako	70/312

4,324,120	4/1982	Gisiger	70/312
4,385,509	5/1983	Milles	70/312

FOREIGN PATENT DOCUMENTS

913134	7/1948	Fed. Rep. of Germany	
2000769	7/1971	Fed. Rep. of Germany	70/312
2030208	4/1980	United Kingdom	70/312

Primary Examiner—Wallace R. Burke
Assistant Examiner—Horace B. Fay
Attorney, Agent, or Firm—Werner W. Kleeman

[57] **CLAIM**

The ornamental design for a dual wheel combination lock for luggage or similar type article-retaining container, as shown and described.

DESCRIPTION

FIG. 1 is a top perspective view in the mounted and closed position of a dual wheel combination lock for luggage or similar type article-retaining container showing my new design wherein the latching portion of the lock is shown engaged with the receiving portion of the lock;

FIG. 2 is a bottom perspective view thereof;

FIG. 3 is an elevational view of the front receiving side thereof, the rear side opposite being substantially flat;

FIG. 4 is an exploded left side elevational view of the lock shown in FIG. 1, the side opposite being a mirror image;

FIG. 5 is a top plan view thereof;

FIG. 6 is an exploded perspective view thereof, as shown in FIG. 1; and

FIG. 7 is a bottom plan view thereof.

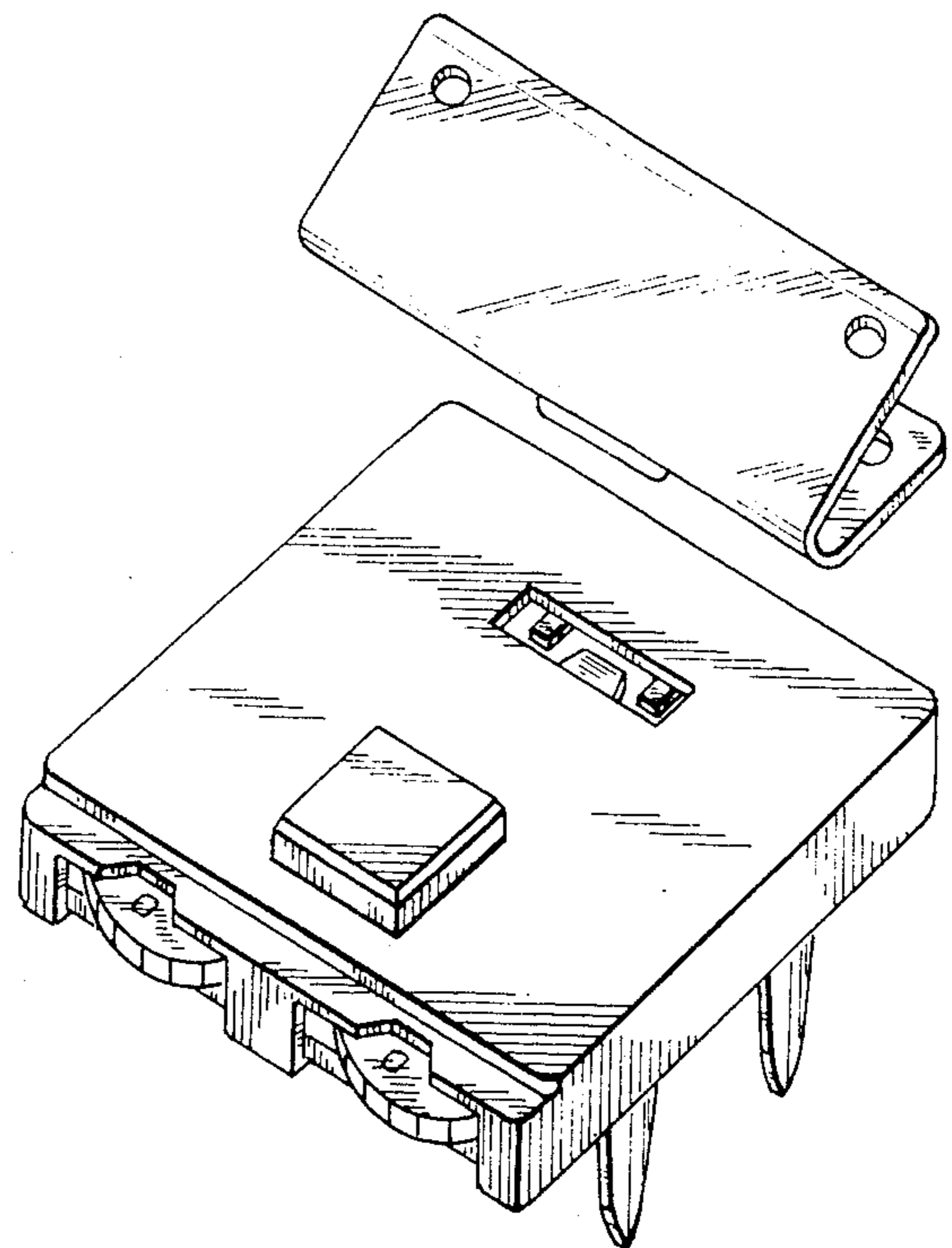
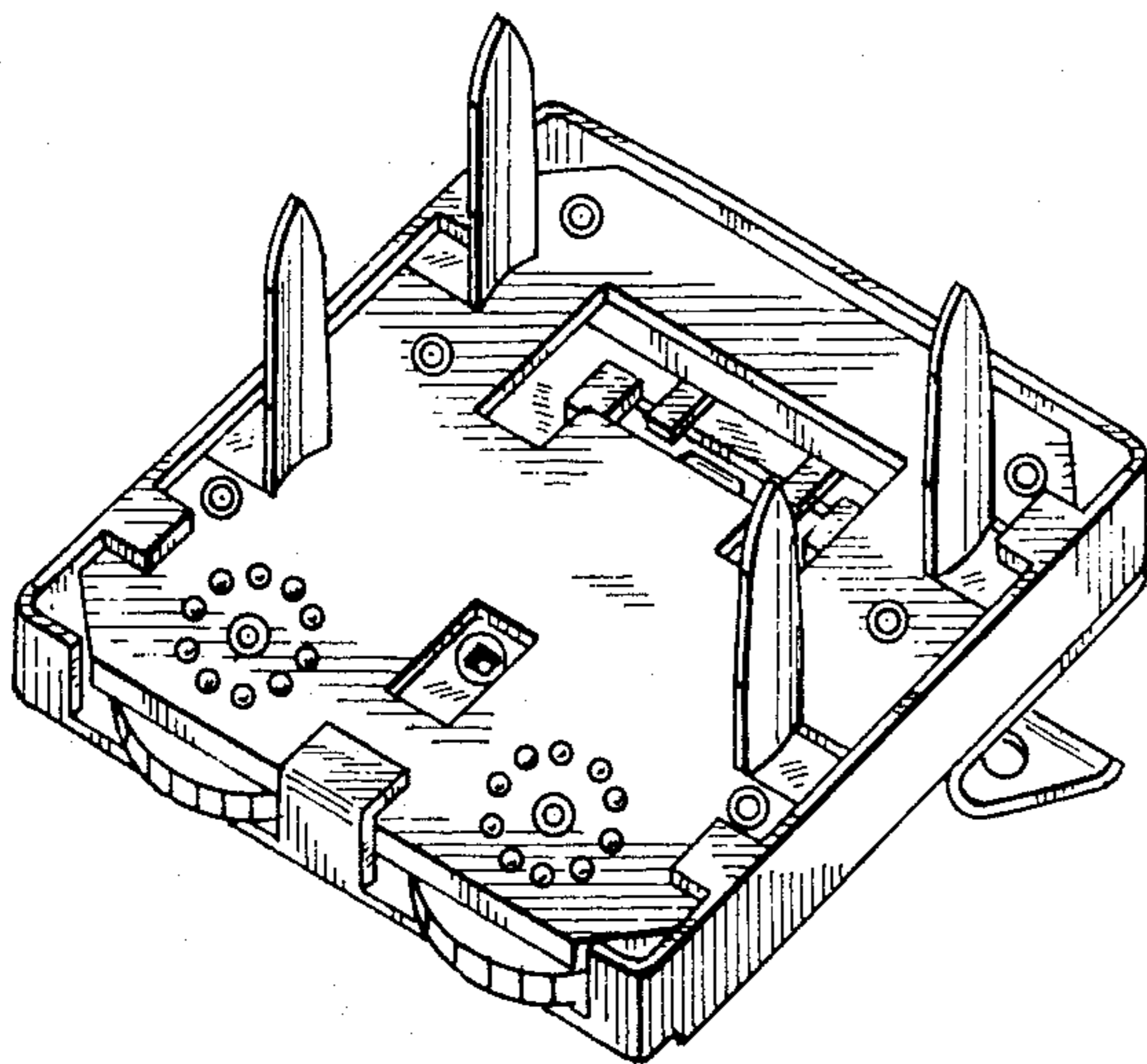

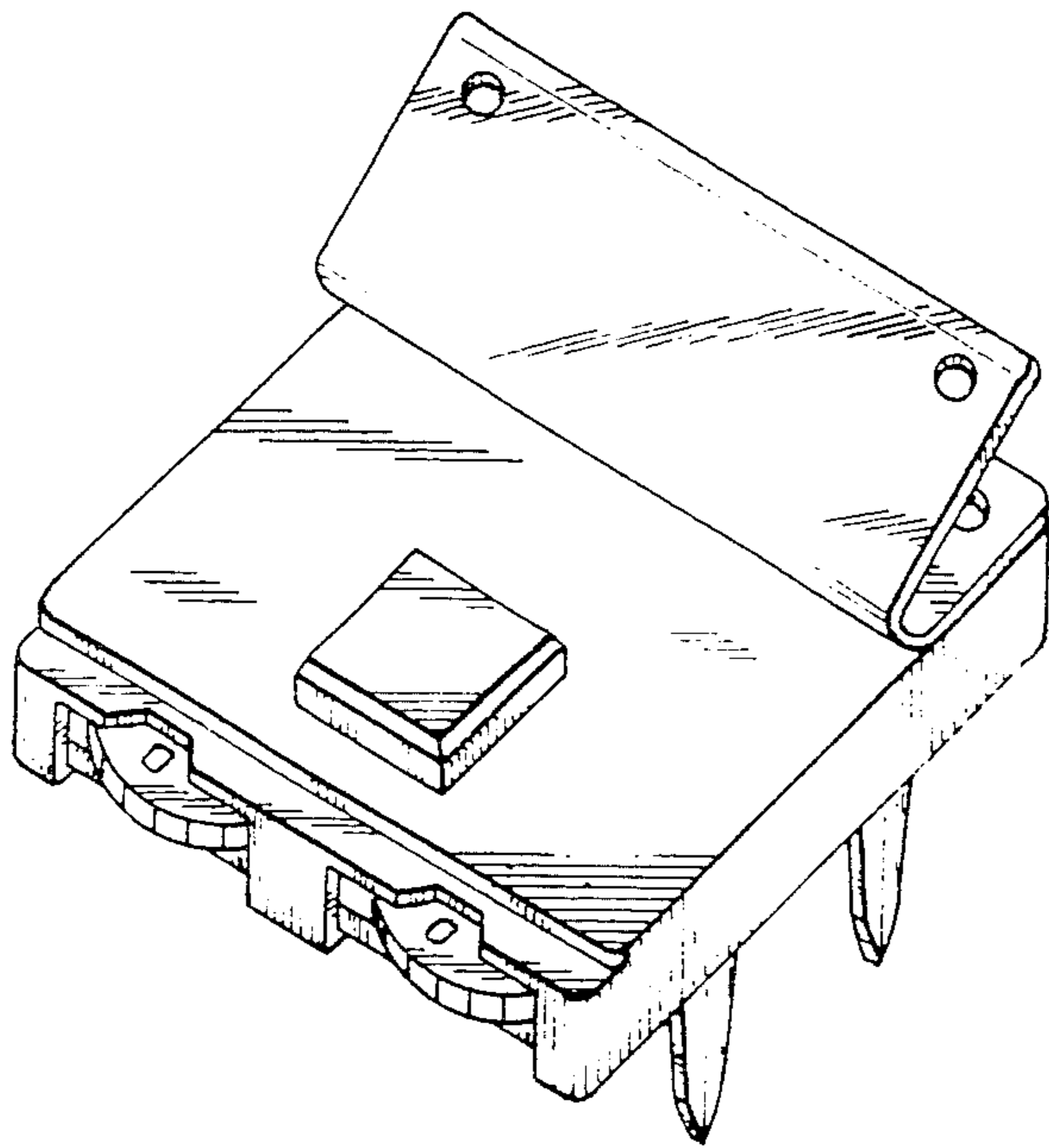

Fig. 1

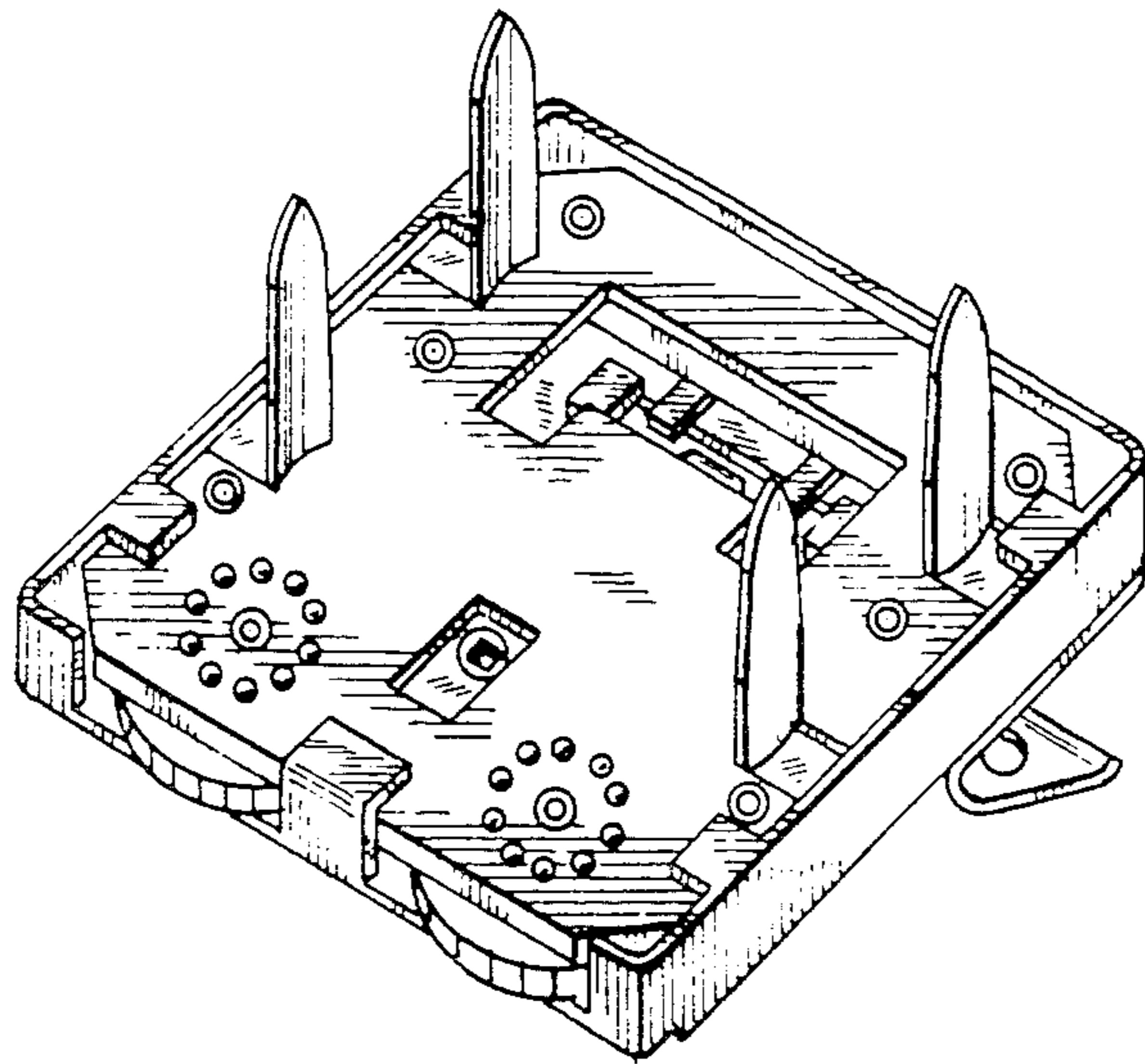

Fig. 2

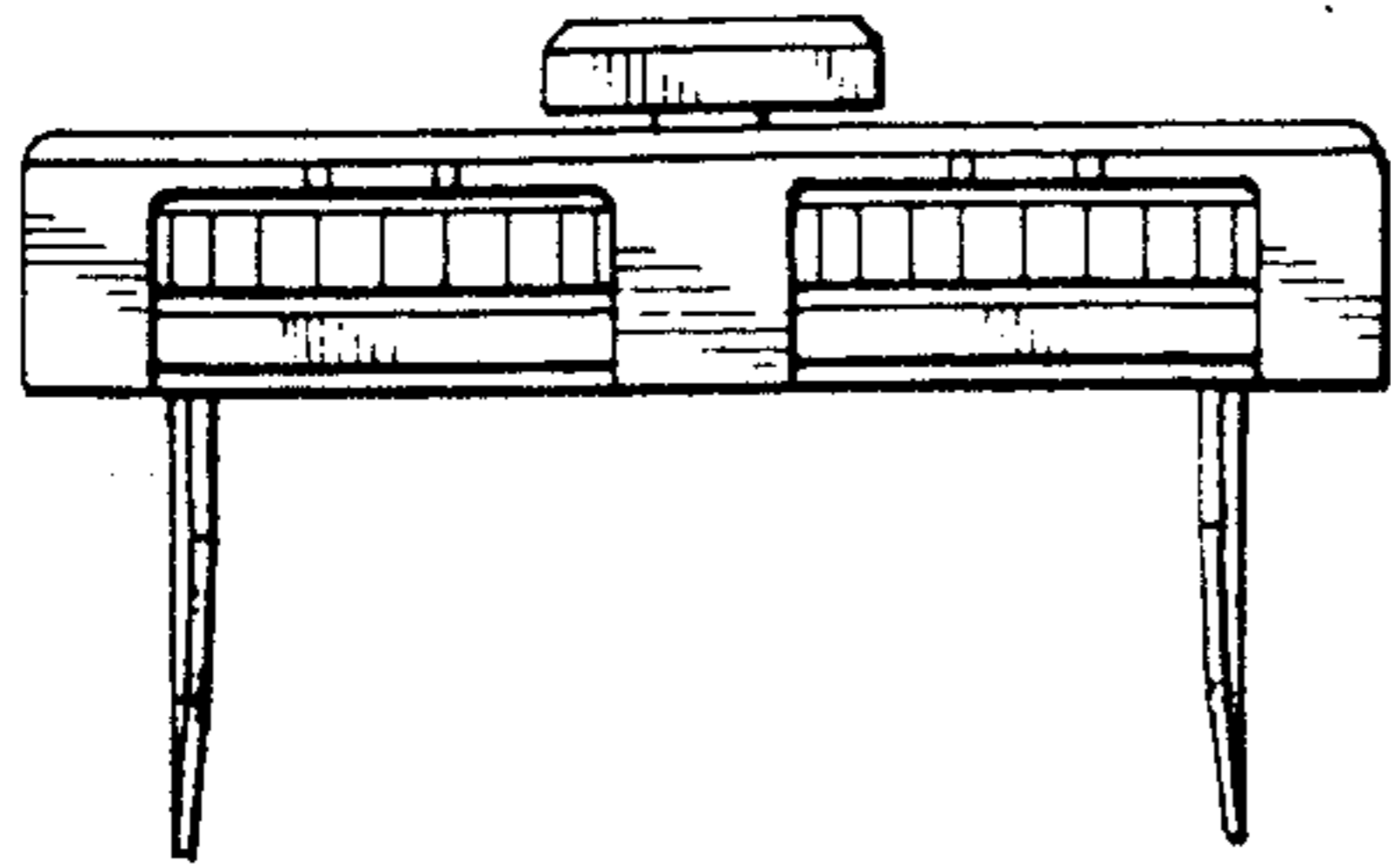

Fig. 3

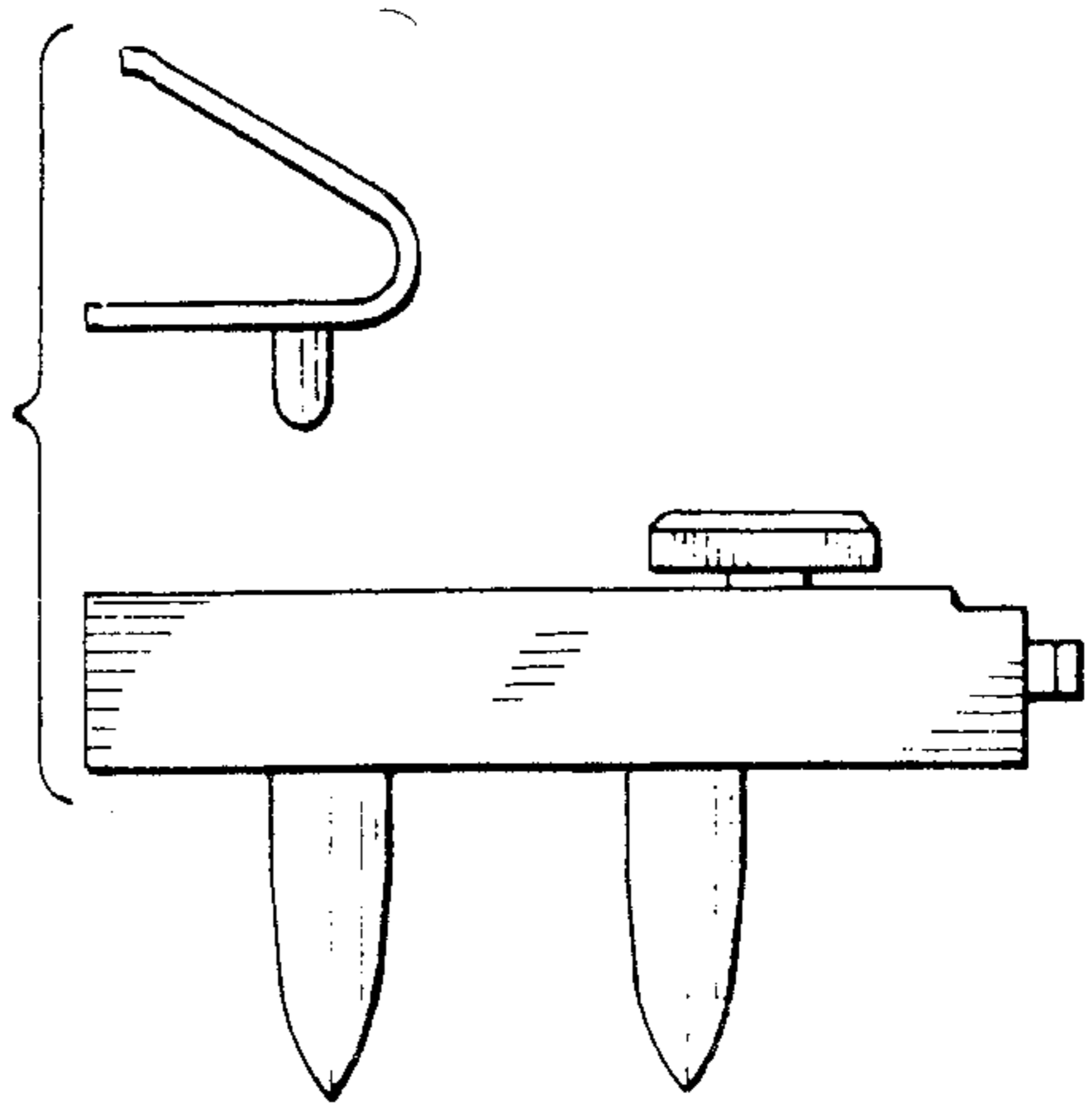

Fig. 4

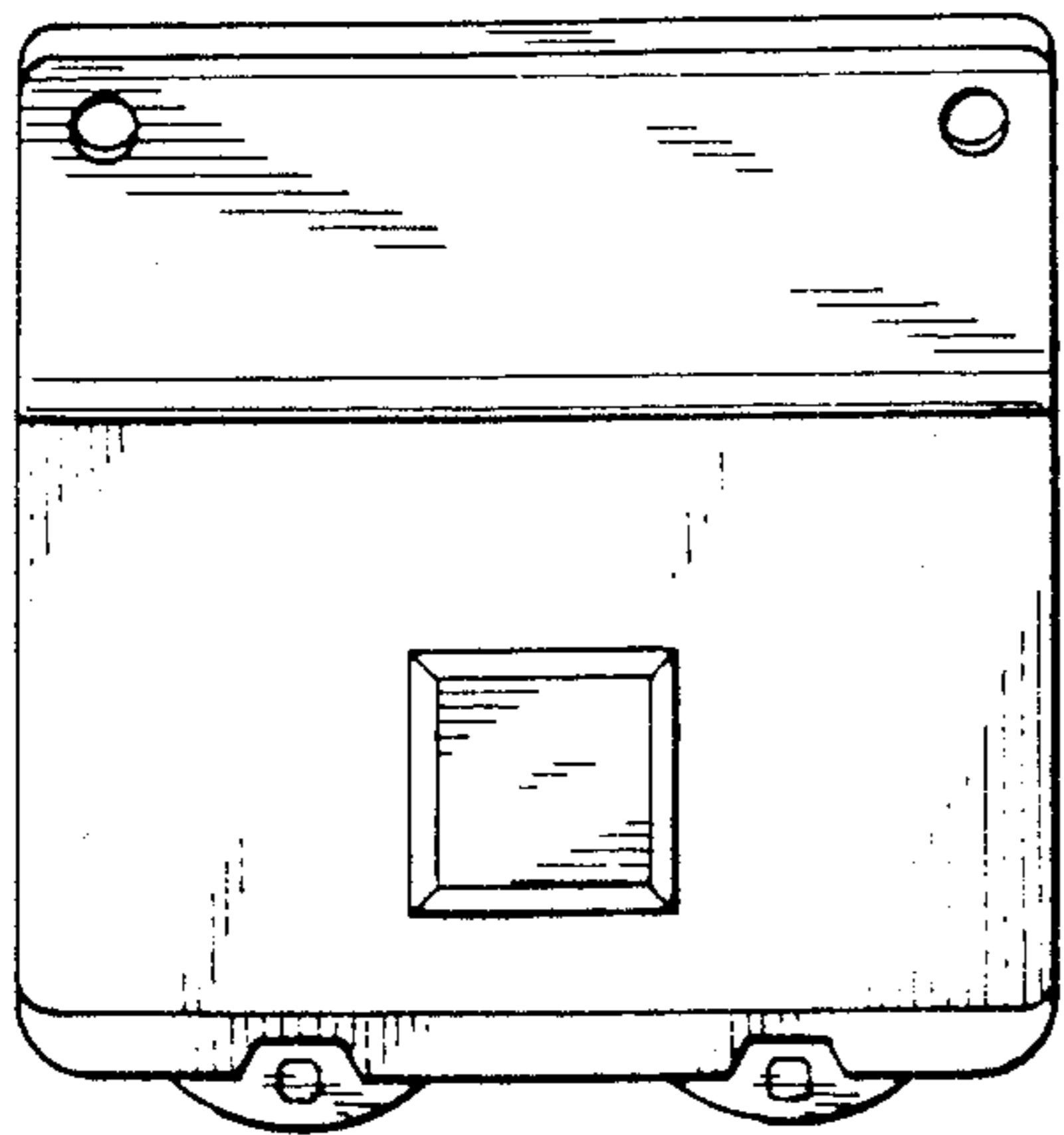

Fig. 5

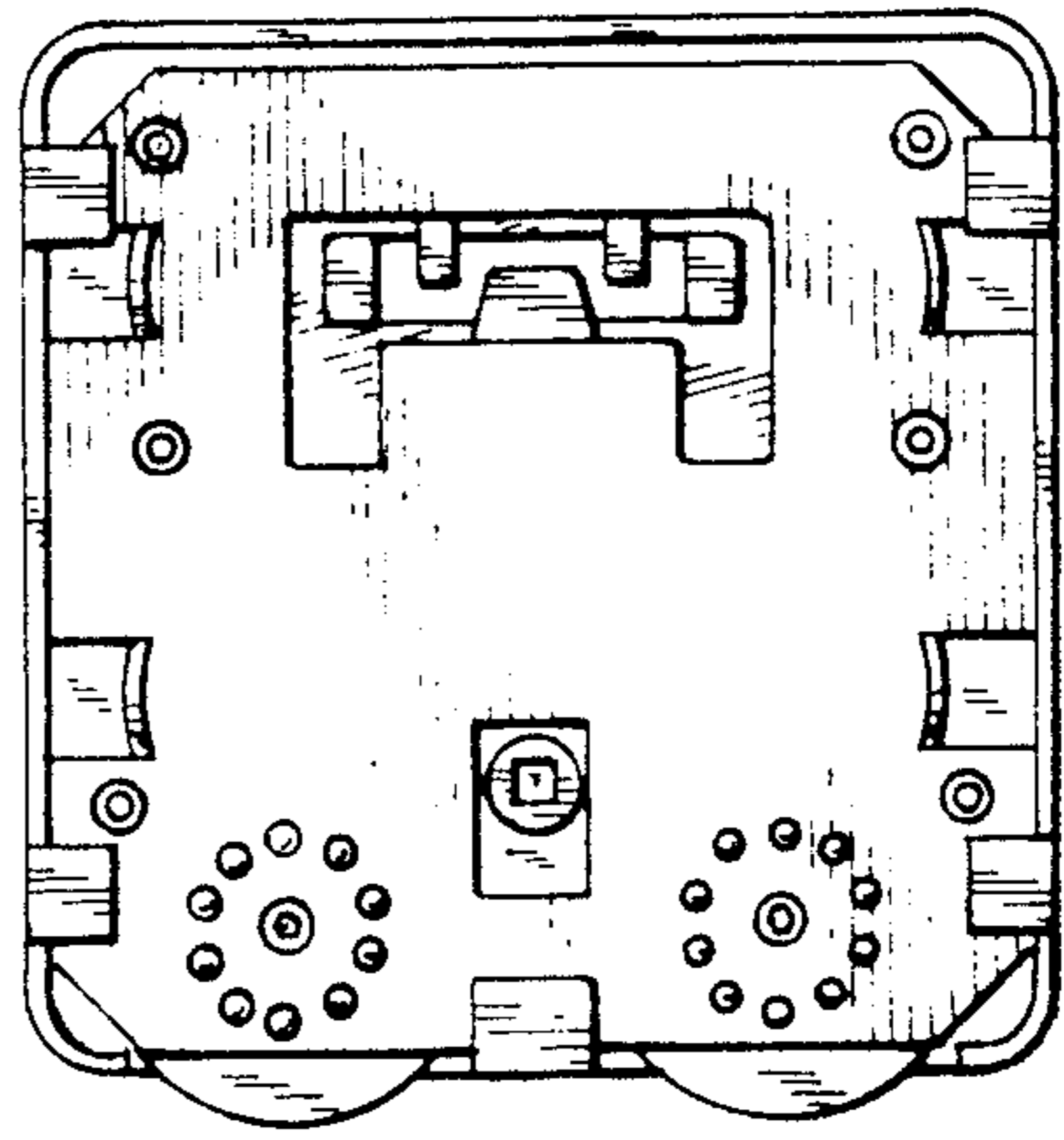

Fig. 7

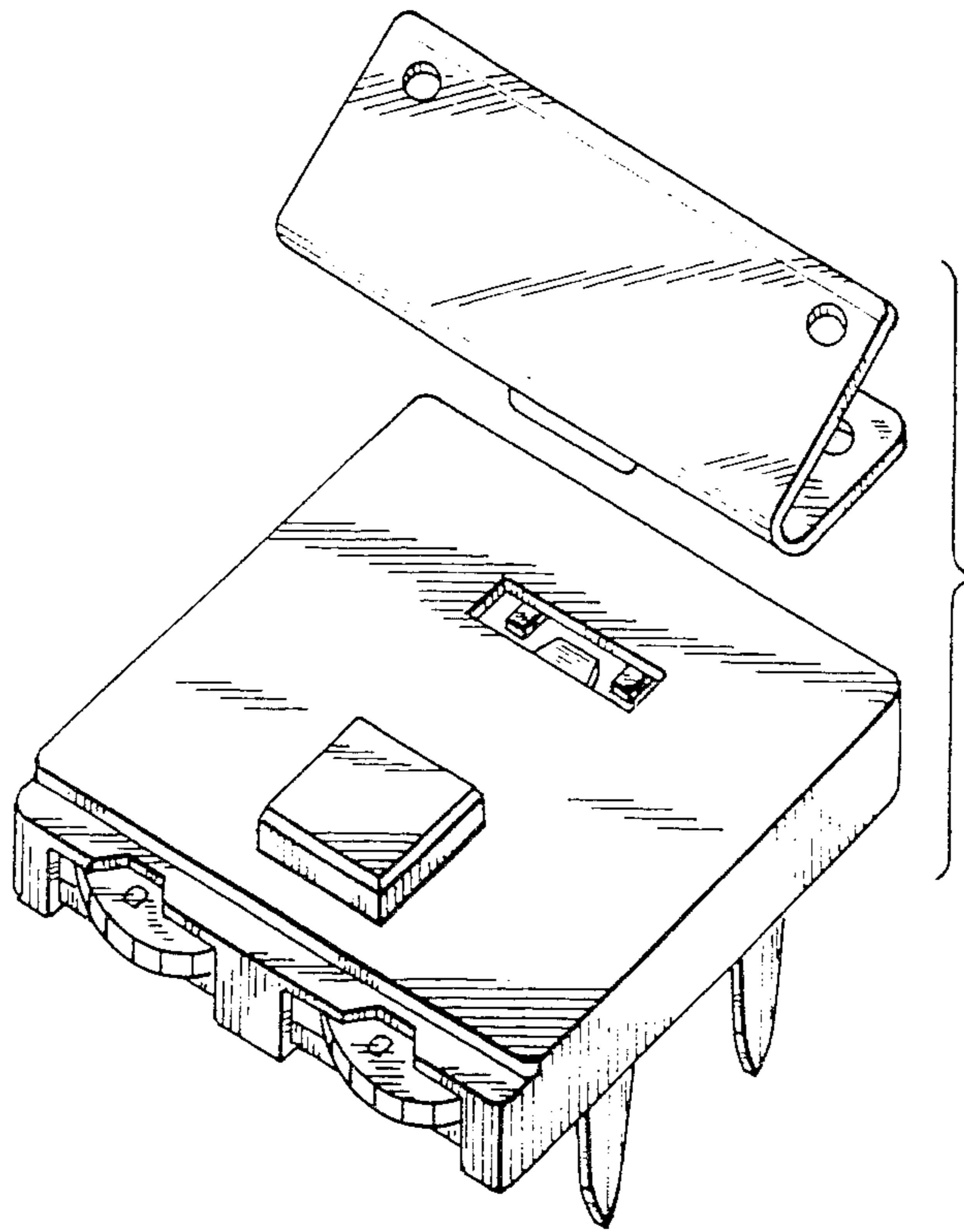

Fig. 6